



FALCON

Rooftop Units

ACPSB 50/60Hz

Cooling Capacity : 29 to 1439 MBH (9 to 422 kW)

Heating Capacity : 27 to 1260 MBH (8 to 369 kW)



DUNHAM-BUSH[®]

Products that perform...By people who care

NOMENCLATURE

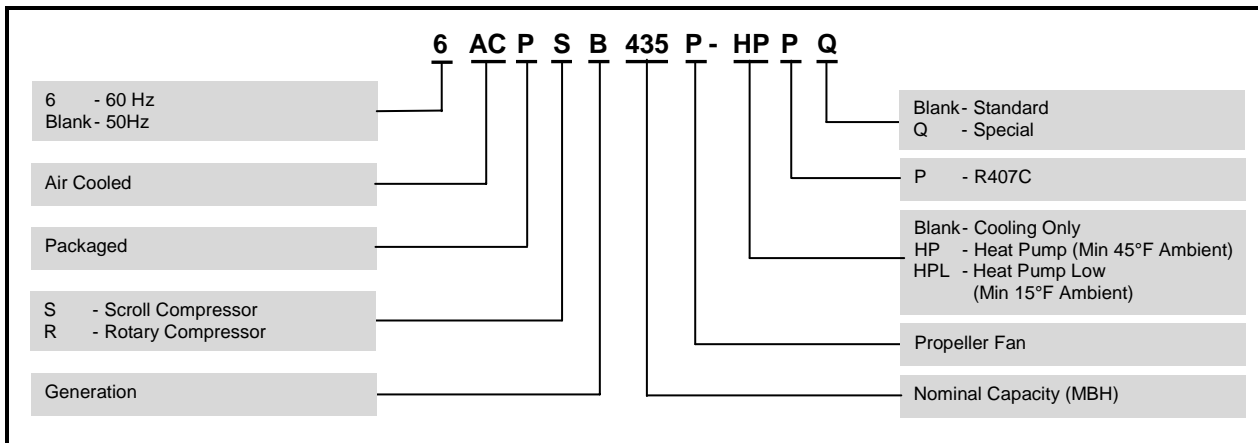

GENERAL DESCRIPTION

The ACPSB-P Series with new features is suitable for hotel, office, hospital, school, factory and supermarket applications. The low noise and compact series are completely leak tested, evacuated, dehydrated and charged with refrigerant prior to shipment. The units are rated in accordance with AHRI standards 340/360.

HERMETIC SCROLL COMPRESSOR(S)

Reliability

- ✦ No contact scroll design that minimizes friction, increases volumetric efficiency and reduces vibration, thus longer service life.
- ✦ Suction gas cooled motor.

Low Power Consumption:

- ✦ High EER.

CLASS F INSULATION CONDENSER FAN MOTOR

- ✦ Extra safety margin and longer motor life even in extreme operating conditions.
- ✦ IP 55 construction ensure extra motor protection (ACPSB Series 68P to 1520P).
- ✦ Low motor speed at 950 rpm ensures quiet condenser fan operation.

MULTIPLE COMPRESSOR (ACPSB Series 220P and above)

- ✦ By cycling off compressor operation to match building load, no energy is being wasted when room load requires lesser cooling capacity.
- ✦ No total shut down when servicing or repairing a faulty compressor.

EFFICIENT CONDENSER COIL

- ✦ Staggered row of 3/8"OD inner groove tubes with 25 to 30% more surface area guarantee better heat transfer.
- ✦ Mechanically expanded into die-formed corrugated aluminum fins.
- ✦ Integral subcooling circuit to maximize efficiency.
- ✦ One or multiple thermal expansion valve promotes efficient cooling and superheat during reverse cycle
- ✦ Leak and pressure tested to 450 psig.

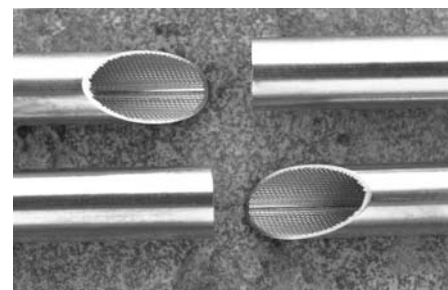

GENERAL DESCRIPTION

SAFETY CONTROL

- ⊗ High-low pressure cutout to protect compressor from high discharge pressure and system leakage.
- ⊗ Suction accumulator to prevent liquid flood back to the compressor during heating cycle

FULLY LEAK TESTED REFRIGERANT CIRCUIT

- ⊗ Compressor, condenser coil, filter drier, sight glass, thermo-expansion valve, distributor and evaporator coil is brazed in complete sealed loop.
- ⊗ Leak and pressure tested at 450 psig.
- ⊗ Pressure ports are provided on the discharge, liquid and suction line.
- ⊗ Evacuated, dehydrated and charge with refrigerant gas prior to shipment.

CASING

- ⊗ Constructed from heavy gauge galvanized steel.
- ⊗ Panels are painted with epoxy powder paint for excellent finish, weatherability and corrosion resistance.
- ⊗ Evaporator section is insulated with 1 x 1 1/2 lb per.cu.ft of linacoustic fiberglass.

EFFICIENT EVAPORATOR COIL

- ⊗ Independent thermal expansion valve with external equalizer for better refrigerant control and wider load condition.
- ⊗ Leak and pressure tested to 450 psig
- ⊗ Evacuated, dehydrated and charged with refrigerant gas.

DRIVE PACKAGE AND BLOWERS

- ⊗ Belt driven drive package offers flexibility on various air flow rate and various static pressure applications (ACPSB Series 160P and above).
- ⊗ Single large diameter double inlet double width blowers (AMCA certified) reduce the noise level and eliminates the need for common transition and eliminates air unbalance.

FILTERS

- ⊗ 1" thick with side loading for ACPSB Series 30P to 145P.
- ⊗ 2" thick with side loading for ACPSB Series 160P and above.



OPTIONAL ACCESSORIES

- ⊗ Factory wired starters
 - DOL for compressors and fan motors.
 - Soft Starter for compressors.
- ⊗ Suction stop valve(s), discharge stop valve(s) and liquid stop valve(s).
- ⊗ Fan staging (ACPSB Series 160P and above) of multiple fans for head pressure control.
- ⊗ Thermostat.
- ⊗ Hydrophilic fins or copper fins for better corrosion resistance.
- ⊗ Hot gas by pass for low load and low ambient conditions.
- ⊗ Electric heaters.

COOLING & HEATING PORTFOLIO

Reference		Capacity		
		Hz	MBH	kW
ACPRB 30	Cooling	50 / 60	29.0 / 30.4	8.5 / 8.9
	Heating	50 / 60	27.0 / 28.0	7.9 / 8.2
ACPSB 40	Cooling	50 / 60	35.8 / 36.2	10.5 / 10.6
	Heating	50 / 60	32.1 / 33.4	9.4 / 9.8
ACPSB 50	Cooling	50 / 60	46.7 / 45.0	13.7 / 13.2
	Heating	50 / 60	43.7 / 39.9	12.8 / 11.7
ACPSB 68	Cooling	50 / 60	60.1 / 59.0	17.6 / 17.3
	Heating	50 / 60	54.9 / 53.2	16.1 / 15.6
ACPSB 81	Cooling	50 / 60	70.3 / 73.4	20.6 / 21.5
	Heating	50 / 60	65.5 / 67.9	19.2 / 19.9
ACPSB 95	Cooling	50 / 60	86.0 / 85.3	25.2 / 25.0
	Heating	50 / 60	76.8 / 75.4	22.5 / 22.1
ACPSB 108	Cooling	50 / 60	101.7 / 107.5	29.8 / 31.5
	Heating	50 / 60	90.4 / 95.5	26.5 / 28.0
ACPSB 125	Cooling	50 / 60	117.0 / 118.1	34.3 / 34.6
	Heating	50 / 60	104.1 / 105.4	30.5 / 30.9
ACPSB 145	Cooling	50 / 60	135.5 / 136.8	39.7 / 40.1
	Heating	50 / 60	116.7 / 122.2	34.2 / 35.8
ACPSB 160	Cooling	50 / 60	143.7 / 154.6	42.1 / 45.3
	Heating	50 / 60	130.3 / 142.6	38.2 / 41.8
ACPSB 190	Cooling	50 / 60	168.6 / 173.3	49.4 / 50.8
	Heating	50 / 60	151.2 / 153.9	44.3 / 45.1
ACPSB 220	Cooling	50 / 60	195.5 / 199.3	57.3 / 58.4
	Heating	50 / 60	174.7 / 180.8	51.2 / 53.0
ACPSB 250	Cooling	50 / 60	229.6 / 232.4	67.3 / 68.1
	Heating	50 / 60	207.5 / 210.2	60.8 / 61.6
ACPSB 290	Cooling	50 / 60	259.0 / 272.6	75.9 / 79.9
	Heating	50 / 60	229.6 / 242.9	67.3 / 71.2
ACPSB 320	Cooling	50 / 60	289.7 / 310.2	84.9 / 90.9
	Heating	50 / 60	261.0 / 284.9	76.5 / 83.5
ACPSB 380	Cooling	50 / 60	339.2 / 348.0	99.4 / 102.0
	Heating	50 / 60	306.4 / 311.9	89.8 / 91.4
ACPSB 435	Cooling	50 / 60	387.6 / 397.5	113.6 / 116.5
	Heating	50 / 60	347.0 / 360.3	101.7 / 105.6
ACPSB 480	Cooling	50 / 60	404.7 / 430.6	118.6 / 126.2
	Heating	50 / 60	377.4 / 413.2	110.6 / 121.1
ACPSB 510	Cooling	50 / 60	439.5 / 476.7	128.8 / 139.7
	Heating	50 / 60	399.6 / 444.3	117.1 / 130.2
ACPSB 570	Cooling	50 / 60	484.5 / 512.5	142.0 / 150.2
	Heating	50 / 60	446.3 / 474.6	130.8 / 139.1
ACPSB 640	Cooling	50 / 60	577.7 / 608.4	169.3 / 178.3
	Heating	50 / 60	496.5 / 535.0	145.5 / 156.8
ACPSB 700	Cooling	50 / 60	617.6 / 669.8	181.0 / 196.3
	Heating	50 / 60	557.5 / 609.4	163.3 / 178.6
ACPSB 760	Cooling	50 / 60	659.6 / 722.0	193.3 / 211.5
	Heating	50 / 60	594.4 / 650.0	174.2 / 190.5
ACPSB 800	Cooling	50 / 60	724.4 / 797.1	212.2 / 233.6
	Heating	50 / 60	644.6 / 728.5	188.9 / 213.5
ACPSB 890	Cooling	50 / 60	805.6 / 865.0	236.0 / 253.4
	Heating	50 / 60	723.0 / 782.1	211.8 / 229.2
ACPSB 960	Cooling	50 / 60	866.7 / 940.0	253.9 / 275.4
	Heating	50 / 60	760.9 / 837.7	222.9 / 245.4
ACPSB 1020	Cooling	50 / 60	934.6 / 1031.8	273.8 / 302.3
	Heating	50 / 60	809.4 / 917.9	237.2 / 268.9
ACPSB 1140	Cooling	50 / 60	1031.8 / 1098.4	302.3 / 321.8
	Heating	50 / 60	912.4 / 975.5	267.3 / 285.8
ACPSB 1340	Cooling	50 / 60	1199.7 / 1234.5	351.5 / 361.7
	Heating	50 / 60	1023.3 / 1076.2	299.8 / 315.3
ACPSB 1520	Cooling	50 / 60	1365.2 / 1438.6	400.0 / 421.5
	Heating	50 / 60	1139.7 / 1259.8	333.9 / 369.1

Notes: 1.) Ratings are gross capacities - For net capacities, deduct evaporator blower motor heat.
 2.) Cooling mode: at 80°F (DB), 67°F (WB) air on evaporator and 95°F ambient air temperature on condenser.
 3.) Heating mode: at 70°F (DB) air on evaporator and 45°F ambient air temperature on condenser.

PHYSICAL SPECIFICATIONS

50 Hz

Model	Compressor			Condenser Coil			Cond. Fan Motor HP (Qty)	Evaporator Blower			Evaporator Coil		Air Filter Size Inches (Qty)	Refrigerant Charge		Approx. Operating Weight (Lbs)	Sound Pressure Level ±2 dB(A)	
	Qty	MRA Each	LRA Each	NRA Each	Face Area ft²	Row / FPI		Standard Size (Qty)	Motor Max HP (Qty)	Fan Min-Max Cfm	Face Area ft²	Row / FPI		Lbs Per System (Qty)				
						Cooling Only								Heat Pump	Cooling Only			Heat Pump
ACPRB 30P	1	1x8.0	1x40	1x5.1	4.6	2/12	3/12	1/5(1)	241-181 (1)	0.4(1)	650 1280	2.1	3/12	16x25x1(1)	4.5(1)	7.2(1)	550	62
ACPSB 40P	1	1x10.0	1x46	1x6.4	7.2	2/12	3/12	1/5(1)	241-181 (1)	0.4(1)	920 1800	3.1	3/12	20x25x1(1)	6.4(1)	9.1(1)	600	62
ACPSB 50P	1	1x11.6	1x61.8	1x7.4	8.3	2/10	3/12	1/5(1)	241-241 (1)	0.4(1)	1100 2200	3.7	3/12	20x25x1(1)	7.2(1)	9.9(1)	650	62
ACPSB 68P	1	1x14.0	1x74	1x9.0	8.3	2/10	2/12	3/4(1)	270-270 (1)	1.0(1)	1400 2800	4.7	3/12	16x25x1(2)	7.5(1)	10.2(1)	1100	66
ACPSB 81P	1	1x17.0	1x101	1x10.9	9.4	2/10	3/12	3/4(1)	270-270 (1)	1.0(1)	1550 3100	5.2	3/12	16x25x1(1) 20x25x1(1)	9.9(1)	15.4(1)	1200	66
ACPSB 95P	1	1x23.0	1x95	1x14.7	10.9	2/12	3/12	3/4(1)	270-270 (1)	1.0(1)	1550 3100	5.2	4/12	16x25x1(1) 20x25x1(1)	12.1(1)	17.6(1)	1300	66
ACPSB 108P	1	1x24.2	1x111	1x15.5	14.2	2/12	3/12	3/4(1)	270-270 (2)	1.0(2)	1850 3600	6.1	4/12	20x25x1(2)	13.2(1)	18.7(1)	1500	66
ACPSB 125P	1	1x26.9	1x118	1x17.2	14.2	3/12	3/12	3/4(1)	270-270 (2)	1.0(2)	2000 3900	6.6	4/12	20x25x1(2)	13.2(1)	18.7(1)	1600	67
ACPSB 145P	1	1x31.0	1x118	1x19.9	16.3	3/10	4/12	3/4(1)	270-270 (2)	1.0(2)	2600 5100	8.5	4/12	20x25x1(2)	15.4(1)	20.9(1)	1750	67
ACPSB 160P	1	1x35.0	1x140	1x22.4	19.5	3/12	3/12	3/4(2)	15x15 (1)	5.5(1)	3500 7000	11.7	3/12	20x20x2(2) 20x25x2(2)	23.1(1)	28.7(1)	1700	69
ACPSB 190P	1	1x42.0	1x174	1x26.9	19.5	2/14	3/12	3/4(2)	15x15 (1)	5.5(1)	3500 7000	11.7	4/12	20x20x2(2) 20x25x2(2)	25.4(1)	30.9(1)	1800	70
ACPSB 220P	2	2x24.2	2x111	2x15.5	19.5	3/12	4/12	3/4(2)	15x15 (1)	5.5(1)	3700 7300	12.3	4/12	20x20x2(2) 20x25x2(2)	13.2(2)	18.7(2)	1900	69
ACPSB 250P	2	2x26.9	2x118	2x17.2	27.4	2/16	4/12	3/4(2)	18x13 (1)	7.5(1)	4400 8700	14.6	4/12	25x25x2(4)	13.2(2)	18.7(2)	2100	71
ACPSB 290P	2	2x31.0	2x118	2x19.9	27.4	3/16	5/12	3/4(2)	18x13 (1)	7.5(1)	5000 10000	16.7	4/12	25x25x2(4)	15.4(2)	20.9(2)	2400	71
ACPSB 320P	2	2x35.0	2x140	2x22.4	37.5	2/14	4/12	3/4(3)	18x18 (1)	15(1)	5850 11600	19.4	4/12	16x25x2(2) 20x25x2(4)	23.1(2)	28.7(2)	2900	71
ACPSB 380P	2	2x42.0	2x174	2x26.9	37.5	3/14	5/12	3/4(3)	18x18 (1)	15(1)	6700 13400	22.6	4/12	16x20x2(3) 20x20x2(6)	25.4(2)	30.9(2)	3000	72
ACPSB 435P	3	3x31.0	3x118	3x19.9	40	4/12	5/12	3/4(3)	450x450 (1)	20(1)	7000 14000	23.3	4/12	16x20x2(3) 20x20x2(6)	15.4(3)	20.9(3)	3100	72
ACPSB 480P	3	3x35.0	3x140	3x22.4	48.3	2/14	4/12	3/4(4)	500x500 (1)	20(1)	8900 17900	29.7	3/12	20x20x2(2) 20x25x2(5) 25x25x2(2)	23.1(3)	28.7(3)	4000	73
ACPSB 510P	3	2x35.0 1x42.0	2x140 1x174	2x22.4 1x26.9	48.3	3/12	4/12	3/4(4)	500x500 (1)	20(1)	8900 17900	29.7	3/13	20x20x2(2) 20x25x2(5) 25x25x2(2)	23.1(2) 25.4(1)	28.7(2) 30.9(1)	4300	73
ACPSB 570P	3	3x42.0	3x174	3x26.9	48.3	4/12	5/12	3/4(4)	500x500 (1)	20(1)	8900 17900	29.7	4/10	20x20x2(2) 20x25x2(5) 25x25x2(2)	25.4(3)	30.9(3)	4400	74
ACPSB 640P	4	4x35.0	4x140	4x22.4	65.3	3/10	3/12	2(4)	560x560 (1)	30(1)	10000 20000	33.4	4/10	20x20x2(4) 20x25x2(8)	23.1(4)	28.7(4)	5800	79
ACPSB 700P	4	2x35.0 2x42.0	2x140 2x174	2x22.4 2x26.9	65.3	3/10	4/12	2(4)	560x560 (1)	30(1)	10000 20000	33.4	4/12	20x20x2(4) 20x25x2(8)	23.1(2) 25.4(2)	28.7(2) 30.9(2)	6100	79
ACPSB 760P	4	4x42.0	4x174	4x26.9	65.3	3/12	4/12	2(4)	560x560 (1)	30(1)	10400 20800	34.7	4/12	20x20x2(4) 20x25x2(8)	25.4(4)	30.9(4)	6300	79
ACPSB 800P	5	5x35.0	5x140	5x22.4	94.0	3/12	4/12	2(4)	630x630 (1)	40(1)	13500 27000	45.1	4/10	20x20x2(4) 20x25x2(9) 25x25x2(2)	23.1(5)	28.7(5)	7000	79
ACPSB 890P	5	2x35.0 3x42.0	2x140 3x174	2x22.4 3x26.9	94.0	4/10	5/12	2(4)	630x630 (1)	40(1)	14000 28000	46.9	4/12	20x20x2(4) 20x25x2(9) 25x25x2(2)	25.4(3) 23.1(2)	30.9(3) 28.7(2)	7100	79
ACPSB 960P	6	6x35.0	6x140	6x22.4	94.0	4/12	5/12	2(4)	630x630 (1)	40(1)	14500 29000	48.6	4/12	20x20x2(4) 20x25x2(9) 25x25x2(2)	23.1(6)	28.7(6)	7400	79
ACPSB 1020P	6	4x35.0 2x42.0	4x140 2x174	4x22.4 2x26.9	123.0	3/12	4/12	2(6)	710x710 (1)	40(1)	16600 33300	55.6	4/10	20x20x2(12) 20x25x2(8)	23.1(4) 25.4(2)	28.7(4) 30.9(2)	9800	81
ACPSB 1140P	6	6x42.0	6x174	6x26.9	123.0	4/10	5/12	2(6)	710x710 (1)	40(1)	19000 38300	63.9	4/10	20x25x2(20)	25.4(6)	30.9(6)	10000	81
ACPSB 1340P	8	6x35.0 2x42.0	6x140 2x174	6x22.4 2x26.9	129.0	4/12	5/12	2(6)	800x800 (1)	50(1)	21600 43300	72.2	4/10	20x20x2(8) 20x25x2(18)	23.1(6) 25.4(2)	28.7(6) 30.9(2)	11200	81
ACPSB 1520P	8	8x42.0	8x174	8x26.9	129.0	4/12	5/12	2(6)	800x800 (1)	50(1)	21600 43300	72.2	5/10	20x20x2(8) 20x25x2(16)	25.4(8)	30.9(8)	11500	82

- Notes:
- 1) Evaporator blower motor for 30P to 145P is 220/240-1-50Hz and direct drive.
 - 2) Condenser fan motors voltage is 220/240-1-50Hz for model 30P to 50P.
 - 3) ACPRB 30P is rotary compressor and the power supply is 220/240-1-50Hz.
 - 4) Sound Pressure Level is calculated based on nominal airflow at external static pressure of 0.5" WG (Model 30-145) / 1.5 WG (Model 160-1520), 3m (9.8ft) distance away from unit at free field. Unit supply and return are assumed to be entirely insulated. The actual sound at field could be affected by the supply and return duct break out noise.
 - 5) Minimum-maximum voltage is 360V to 440V.
 - 6) LRA - Locked Rotor Amp.
 - 7) NRA - Nominal Running Amp.
 - 8) MRA - Maximum Running Amp.



Product that perform...By people who care

PHYSICAL SPECIFICATIONS

60 Hz

Model	Compressor				Condenser Coil			Cond. Fan Motor HP (Qty)	Evaporator Blower			Evaporator Coil		Air Filter	Refrigerant Charge		Approx. Operating Weight (Lbs)	Sound Pressure Level ±2 dB(A)
	Qty	MRA Each	LRA Each	NRA Each	Face Area ft ²	Row / FPI			Standard Size (Qty)	Motor Max HP	Fan Min-Max Cfm	Face Area ft ²	Row/ FPI	Size Inches (Qty)	Lbs Per System (Qty)			
						Cooling Only	Heat Pump								Cooling Only	Heat Pump		
6ACPRB 30P	1	1x7.0	1x31.0	1x4.5	4.6	2/12	3/12	1/5(1)- 230V 5/8(1)- 460V	241-181 (1)	0.4(1)	650 1280	2.1	3/12	16x25x1 (1)	3.5(1)	3.5(1)	550	62
6ACPRB 40P	1	1x8.0	1x39.0	1x5.1	7.2	2/12	3/12	1/5(1)- 230V 5/8(1)- 460V	241-181 (1)	0.4(1)	920 1800	3.1	3/12	20x25x1 (1)	3.7(1)	3.7(1)	600	62
6ACPSB 50P	1	1x10.0	1x44	1x6.4	8.3	2/10	3/12	1/5(1)- 230V 5/8(1)- 460V	241-181 (1)	0.4(1)	1100 2200	3.7	3/12	20x25x1 (1)	4.8(1)	4.8(1)	650	62
6ACPSB 68P	1	1x11.6	1x59.6	1x7.4	8.3	2/10	2/12	1(1)	241-181 (1)	0.4(1)	1400 2800	4.7	3/12	16x25x1 (2)	5.9(1)	5.9(1)	1100	66
6ACPSB 81P	1	1x14.0	1x75	1x9.0	9.4	2/10	3/12	1(1)	241-181 (1)	0.4(1)	1550 3100	5.2	3/12	16x25x1 (1) 20x25x1 (1)	8.3(1)	8.3(1)	1200	66
6ACPSB 95P	1	1x17.0	1x100	1x10.9	10.9	2/12	3/12	1(1)	241-181 (1)	0.4(1)	1550 3100	5.2	4/12	16x25x1 (1) 20x25x1 (1)	9.9(1)	9.9(1)	1300	66
6ACPSB 108P	1	1x23.0	1x95.0	1x14.7	14.2	2/12	3/12	1(1)	241-181 (1)	0.4(1)	1850 3600	6.1	4/12	20x25x1 (2)	12.3(1)	12.3(1)	1500	66
6ACPSB 125P	1	1x24.2	1x114	1x15.5	14.2	3/12	3/12	1(1)	241-181 (1)	0.4(1)	2000 3900	6.6	4/12	20x25x1 (2)	13.2(1)	13.2(1)	1600	67
6ACPSB 145P	1	1x26.9	1x125	1x17.2	16.3	3/10	4/12	1(1)	241-181 (1)	0.4(1)	2600 5100	8.5	4/12	20x25x1 (2)	17.6(1)	17.6(1)	1750	67
6ACPSB 160P	1	1x29.0	1x125	1x18.6	19.5	3/12	3/12	1(2)	15x15 (1)	5.5(1)	3500 7000	11.7	3/12	20x20x2 (2) 20x25x2 (2)	16.0(1)	16.0(1)	2100	69
6ACPSB 190P	1	1x35.0	1x140	1x22.4	19.5	2/14	3/12	1(2)	15x15 (1)	5.5(1)	3500 7000	11.7	4/12	20x20x2 (2) 20x25x2 (2)	23.8(1)	23.8(1)	2300	70
6ACPSB 220P	1	1x42.0	1x174	1x26.9	19.5	3/12	4/12	1(2)	15x15 (1)	5.5(1)	3700 7300	12.3	4/12	20x20x2 (2) 20x25x2 (2)	25.3(1)	25.3(1)	2600	69
6ACPSB 250P	2	2x24.2	2x114	2x15.5	27.4	2/16	4/12	1(2)	18x13 (1)	7.5(1)	4400 8700	14.6	4/12	25x25x2 (4)	13.2(2)	13.2(2)	2800	71
6ACPSB 290P	2	2x26.9	2x125	2x17.2	27.4	3/16	5/12	1(2)	18x13 (1)	7.5(1)	5000 10000	16.7	4/12	25x25x2 (4)	17.6(2)	17.6(2)	3000	71
6ACPSB 320P	2	2x29.0	2x125	2x18.6	37.5	2/14	4/12	1(3)	18x18 (1)	10(1)	5850 11600	19.4	4/12	16x25x2 (2) 20x25x2 (4)	16.0(2)	16.0(2)	4000	71
6ACPSB 380P	2	2x35.0	2x140	2x22.4	37.5	3/14	5/12	1(3)	18x18 (1)	10(1)	6700 13400	22.6	4/12	16x20x2 (3) 20x20x2 (6)	23.8(2)	23.8(2)	4400	72
6ACPSB 435P	2	2x42.0	2x174	2x26.9	40.0	4/12	5/12	1(3)	450x450 (1)	20(1)	7000 14000	23.3	4/12	16x20x2 (3) 20x20x2 (6)	25.3(2)	25.3(2)	4700	72
6ACPSB 480P	3	3x29.0	3x125	3x18.6	48.3	2/14	4/12	1(4)	500x500 (1)	20(1)	8900 17900	29.7	3/12	20x20x2 (2) 20x25x2 (5) 25x25x2 (2)	16.0(3)	16.0(3)	5500	73
6ACPSB 510P	3	3x35.0	3x140	3x22.4	48.3	3/12	4/12	1(4)	500x500 (1)	20(1)	8900 17900	29.7	3/13	20x20x2 (2) 20x25x2 (5) 25x25x2 (2)	23.8(3)	23.8(3)	5700	73
6ACPSB 570P	3	2x35.0 2x42.0	2x140 2x174	2x22.4 2x26.9	48.3	4/12	5/12	1(4)	500x500 (1)	20(1)	8900 17900	29.7	4/10	20x20x2 (2) 20x25x2 (5) 25x25x2 (2)	23.8(2) 25.3(1)	23.8(2) 25.3(1)	5950	74
6ACPSB 640P	3	3x42.0	3x174	3x26.9	65.3	3/10	3/12	2 2/3 (4)	560x560 (1)	30(1)	10000 20000	33.4	4/10	20x20x2 (4) 20x25x2 (8)	25.3(3)	25.3(3)	6500	79
6ACPSB 700P	4	4x35.0	4x140	4x22.4	65.3	3/10	4/12	2 2/3 (4)	560x560 (1)	30(1)	10000 20000	33.4	4/12	20x20x2 (4) 20x25x2 (8)	23.8(4)	23.8(4)	5800	79
6ACPSB 760P	4	2x35.0 2x42.0	2x140 2x174	2x22.4 2x26.9	65.3	3/12	4/12	2 2/3 (4)	560x560 (1)	30(1)	10400 20800	34.7	4/12	20x20x2 (4) 20x25x2 (8)	23.8(2) 25.3(2)	23.8(2) 25.3(2)	6100	79
6ACPSB 800P	4	4x42.0	4x174	4x26.9	94.0	3/12	4/12	2 2/3 (4)	630x630 (1)	40(1)	13500 27000	45.1	4/10	20x20x2 (4) 20x25x2 (9) 25x25x2 (2)	25.3(4)	25.3(4)	6300	79
6ACPSB 890P	5	5x35.0	5x140	5x22.4	94.0	4/10	5/12	2 2/3 (4)	630x630 (1)	40(1)	14000 28000	46.9	4/12	20x20x2 (4) 20x25x2 (9) 25x25x2 (2)	23.8(5)	23.8(5)	7000	79
6ACPSB 960P	6	6x29.0	6x125	6x18.6	94.0	4/12	5/12	2 2/3 (4)	630x630 (1)	40(1)	14500 29000	48.6	4/12	20x20x2 (4) 20x25x2 (9) 25x25x2 (2)	16.0(6)	16.0(6)	7100	79
6ACPSB 1020P	6	2x35.0 4x29.0	2x140 4x125	2x22.4 4x18.6	123.0	3/12	4/12	2 2/3 (6)	710x710 (1)	40(1)	16600 33300	55.6	4/10	20x20x2 (12) 20x25x2 (8)	16.0(4) 23.8(2)	16.0(4) 23.8(2)	7400	81
6ACPSB 1140P	6	4x35.0 2x42.0	4x140 2x174	4x22.4 2x26.9	123.0	4/10	5/12	2 2/3 (6)	710x710 (1)	40(1)	19000 38300	63.9	4/10	20x25x2 (20)	23.8(4) 25.3(2)	23.8(4) 25.3(2)	9800	81
6ACPSB 1340P	6	6x42.0	6x174	6x26.9	129.0	4/12	5/12	2 2/3 (6)	800x800 (1)	50(1)	21600 43300	72.2	4/10	20x20x2 (8) 20x25x2 (16)	25.3(6)	25.3(6)	10000	81
6ACPSB 1520P	8	6x35.0 2x42.0	6x140 2x174	6x22.4 2x26.9	129.0	4/12	5/12	2 2/3 (6)	800x800 (1)	50(1)	21600 43300	72.2	5/10	20x20x2 (8) 20x25x2 (16)	23.8(6) 25.3(2)	23.8(6) 25.3(2)	11200	82

- Notes: 1) Evaporator Blower motor for 6ACPRB 30P to 145P is 220/240-1-60Hz and direct drive.
2) Condenser fan motors voltage is 220/240-1-60Hz for model 30P to 50P.
3) 6ACPRB 30P & 6ACPRB 40P is rotary compressor and the power supply is 230-1-60Hz.
4) Sound Pressure Level is calculated based on nominal airflow at external static pressure of 0.5" WG (Model 30-145) / 1.5 WG (Model 160-1520), 3m (9.8ft) distance away from unit at free field. Unit supply and return are assumed to be entirely insulated. The actual sound at field could be affected by the supply and return duct break out noise.
5) LRA - Locked Rotor Amp.
6) NRA - Nominal Running Amp.
7) MRA - Maximum Running Amp.



Product that perform...By people who care

SYSTEM COOLING CAPACITY

PERFORMANCE DATA – COOLING ONLY

Model	Std. Capacity MBH	Air On Evap.		Cooling Capacity @ Air Temperature On Condenser Coil																
		CFM [m³/h]	WB Temp		95°F [35°C]						105°F [41°C]					115°F [46°C]				
			°F	°C	Total		Sensible		KW Input ³	Total		Sensible		KW Input ³	Total		Sensible		KW Input ³	
					MBH ¹	kW ¹	MBH ²	kW ²		MBH ¹	kW ¹	MBH ²	kW ²		MBH ¹	kW ¹	MBH ²	kW ²		
ACPRB 30PP	29.0	1,000 [1,699]	72	22.2	31.7	9.3	17.4	5.1	3.1	30.4	8.9	17.1	5.0	3.5	31.6	9.3	24.6	7.2	4.4	
			67	19.4	29.0	8.5	22.2	6.5	3.0	27.6	8.1	21.0	6.2	3.4	26.3	7.7	21.2	6.2	3.8	
			62	16.7	27.0	7.9	27.0	7.9	3.0	25.9	7.6	22.9	6.7	3.4	24.6	7.2	22.5	6.6	3.8	
ACPSB 40PP	35.8	1,400 [2,379]	72	22.2	38.9	11.4	21.8	6.4	3.5	37.2	10.9	21.2	6.2	3.9	35.1	10.3	20.5	6.0	4.4	
			67	19.4	35.8	10.5	28.0	8.2	3.4	33.8	9.9	27.3	8.0	3.9	32.1	9.4	26.6	7.8	4.3	
			62	16.7	33.4	9.8	29.7	8.7	3.4	31.7	9.3	29.7	8.7	3.8	30.4	8.9	24.9	7.3	4.3	
ACPSB 50PP	46.7	1,600 [2,718]	72	22.2	50.5	14.8	26.6	7.8	4.8	48.1	14.1	25.9	7.6	5.4	45.5	13.3	25.7	7.5	5.5	
			67	19.4	46.7	13.7	33.8	9.9	4.7	44.0	12.9	32.4	9.5	5.2	41.9	12.3	26.4	7.7	5.3	
			62	16.7	43.0	12.6	40.3	11.8	4.6	41.3	12.1	39.2	11.5	5.1	40.6	11.9	28.9	8.5	4.9	
ACPSB 68PP	60.1	2,000 [3,398]	72	22.2	64.8	19.0	33.8	9.9	6.5	62.4	18.3	32.8	9.6	7.1	59.0	17.3	31.4	9.2	7.7	
			67	19.4	60.1	17.6	42.3	12.4	6.3	57.7	16.9	41.3	12.1	6.9	53.9	15.8	39.6	11.6	7.5	
			62	16.7	54.9	16.1	50.2	14.7	6.2	52.5	15.4	49.1	14.4	6.8	50.2	14.7	47.8	14.0	7.4	
ACPSB 81PP	70.3	2,400 [4,078]	72	22.2	76.8	22.5	42.0	12.3	7.6	73.4	21.5	40.6	11.9	8.4	69.6	20.4	39.2	11.5	9.2	
			67	19.4	70.3	20.6	53.2	15.6	7.4	66.9	19.6	51.9	15.2	8.2	63.5	18.6	50.2	14.7	9.0	
			62	16.7	65.5	19.2	64.5	18.9	7.3	62.1	18.2	62.1	18.2	8.1	59.0	17.3	57.3	16.8	8.9	
ACPSB 95PP	86.0	2,600 [4,417]	72	22.2	93.8	27.5	49.1	14.4	8.6	89.1	26.1	47.1	13.8	9.6	83.6	24.5	45.4	13.3	10.6	
			67	19.4	86.0	25.2	61.4	18.0	8.5	81.2	23.8	59.4	17.4	9.4	76.4	22.4	57.3	16.8	10.4	
			62	16.7	79.5	23.3	73.7	21.6	8.3	75.4	22.1	71.7	21.0	9.3	70.6	20.7	69.3	20.3	10.3	
ACPSB 108PP	101.7	3,200 [5,437]	72	22.2	110.6	32.4	60.4	17.7	9.7	105.4	30.9	58.7	17.2	10.7	100.0	29.3	57.0	16.7	11.7	
			67	19.4	101.7	29.8	77.5	22.7	9.5	96.9	28.4	75.4	22.1	10.5	92.1	27.0	73.4	21.5	11.5	
			62	16.7	95.2	27.9	94.9	27.8	9.4	90.8	26.6	78.8	23.1	10.3	86.7	25.4	76.4	22.4	11.3	
ACPSB 125PP	117.0	3,500 [5,947]	72	22.2	127.3	37.3	69.6	20.4	11.3	121.5	35.6	67.6	19.8	12.6	114.6	33.6	65.2	19.1	13.9	
			67	19.4	117.0	34.3	88.7	26.0	11.1	111.6	32.7	86.3	25.3	12.3	105.4	30.9	83.9	24.6	13.6	
			62	16.7	109.2	32.0	108.2	31.7	10.9	104.1	30.5	104.1	30.5	12.0	99.0	29.0	94.9	27.8	13.4	
ACPSB 145PP	135.5	4,000 [6,796]	72	22.2	147.4	43.2	82.2	24.1	13.0	139.6	40.9	79.5	23.3	14.4	129.7	38.0	76.1	22.3	15.9	
			67	19.4	135.5	39.7	105.4	30.9	12.7	128.3	37.6	102.4	30.0	14.1	120.4	35.3	99.0	29.0	15.6	
			62	16.7	126.6	37.1	117.7	34.5	12.5	120.4	35.3	105.1	30.8	13.8	114.0	33.4	104.4	30.6	15.4	
ACPSB 160PP	143.7	4,600 [7,815]	72	22.2	157.3	46.1	83.3	24.4	15.7	149.5	43.8	80.5	23.6	17.1	141.6	41.5	77.8	22.8	18.6	
			67	19.4	143.7	42.1	104.1	30.5	15.4	135.5	39.7	100.7	29.5	16.7	128.0	37.5	97.6	28.6	18.3	
			62	16.7	131.7	38.6	123.9	36.3	15.2	124.9	36.6	120.8	35.4	16.5	117.0	34.3	117.0	34.3	18.0	
ACPSB 190PP	168.6	4,800 [8,155]	72	22.2	185.6	54.4	97.2	28.5	18.6	175.7	51.5	93.2	27.3	20.3	165.5	48.5	89.4	26.2	22.2	
			67	19.4	168.6	49.4	120.1	35.2	18.2	160.0	46.9	116.4	34.1	19.8	150.8	44.2	112.6	33.0	21.7	
			62	16.7	156.3	45.8	143.3	42.0	17.9	148.4	43.5	139.6	40.9	19.5	139.6	40.9	135.1	39.6	21.3	
ACPSB 220PP	195.5	5,400 [9,175]	72	22.2	211.9	62.1	110.6	32.4	20.7	202.7	59.4	106.8	31.3	22.6	191.4	56.1	102.4	30.0	24.7	
			67	19.4	195.5	57.3	137.5	40.3	20.3	183.9	53.9	132.0	38.7	22.1	175.0	51.3	128.6	37.7	24.2	
			62	16.7	179.1	52.5	162.4	47.6	19.9	170.9	50.1	158.7	46.5	21.7	162.4	47.6	154.6	45.3	23.8	
ACPSB 250PP	229.6	6,400 [10,874]	72	22.2	250.1	73.3	132.0	38.7	24.3	238.8	70.0	127.3	37.3	26.7	238.2	69.8	120.0	35.2	33.7	
			67	19.4	229.6	67.3	162.8	47.7	23.6	217.0	63.6	157.6	46.2	25.9	205.4	60.2	152.5	44.7	28.6	
			62	16.7	211.9	62.1	193.8	56.8	23.0	201.7	59.1	188.7	55.3	25.4	190.4	55.8	183.2	53.7	28.1	
ACPSB 290PP	259.0	7,500 [12,743]	72	22.2	284.2	83.3	150.8	44.2	27.6	268.5	78.7	144.3	42.3	30.4	267.1	78.3	143.2	42.0	38.4	
			67	19.4	259.0	75.9	186.0	54.5	26.8	245.3	71.9	180.5	52.9	29.6	230.3	67.5	174.0	51.0	32.6	
			62	16.7	240.9	70.6	222.8	65.3	26.3	228.3	66.9	216.7	63.5	29.0	213.6	62.6	209.5	61.4	32.0	
ACPSB 320PP	289.7	8,000 [13,592]	72	22.2	318.4	93.3	168.9	49.5	33.0	303.0	88.8	162.4	47.6	35.9	284.2	83.3	154.6	45.3	39.0	
			67	19.4	289.7	84.9	206.1	60.4	32.3	273.7	80.2	198.9	58.3	35.0	258.3	75.7	192.8	56.5	38.2	
			62	16.7	266.1	78.0	244.3	71.6	31.7	252.5	74.0	237.5	69.6	34.5	320.4	93.9	317.7	93.1	51.5	

Notes: 1) Ratings are based on 80°F [27°C] air on evaporator dry bulb temperature.
 2) Ratings are gross capacities. For net capacity deduct evaporator blower motor heat.
 3) kW input shown in the table is total compressor(s) power input.



Product that perform...By people who care

SYSTEM COOLING CAPACITY

PERFORMANCE DATA – COOLING ONLY

Model	Std. Capacity MBH	Air On Evap.		Cooling Capacity @ Air Temperature On Condenser Coil																
		CFM [m³/h]	WB Temp		95°F [35°C]						105°F [41°C]						115°F [46°C]			
			°F	°C	Total		Sensible		KW Input ³	Total		Sensible		KW Input ³	Total		Sensible		KW Input ³	
					MBH ¹	kW ¹	MBH ²	kW ²		MBH ¹	kW ¹	MBH ²	kW ²		MBH ¹	kW ¹	MBH ²	kW ²		
ACPSB 380PP	339.2	9,200 [15,631]	72	22.2	369.5	108.3	195.9	57.4	38.8	351.5	103.0	188.0	55.1	42.2	329.6	96.6	178.8	52.4	45.9	
			67	19.4	339.2	99.4	239.9	70.3	37.9	319.4	93.6	231.3	67.8	41.2	301.0	88.2	223.5	65.5	44.9	
			62	16.7	311.9	91.4	284.2	83.3	37.2	296.2	86.8	276.4	81.0	40.5	278.4	81.6	267.5	78.4	44.1	
ACPSB 435PP	387.6	11,500 [19,539]	72	22.2	425.5	124.7	229.0	67.1	44.9	402.0	117.8	219.1	64.2	49.1	376.1	110.2	195.4	57.3	56.2	
			67	19.4	387.6	113.6	282.2	82.7	43.7	367.5	107.7	273.7	80.2	47.8	345.0	101.1	264.4	77.5	52.5	
			62	16.7	361.0	105.8	338.1	99.1	42.9	341.9	100.2	328.6	96.3	46.9	320.4	93.9	317.7	93.1	51.5	
ACPSB 480PP	404.7	12,000 [20,388]	72	22.2	439.5	128.8	231.0	67.7	52.6	418.3	122.6	222.5	65.2	57.1	392.1	114.9	211.9	62.1	62.1	
			67	19.4	404.7	118.6	285.9	83.8	51.6	380.8	111.6	275.4	80.7	55.9	356.2	104.4	264.8	77.6	60.8	
			62	16.7	367.8	107.8	336.4	98.6	50.5	348.4	102.1	327.2	95.9	54.9	328.2	96.2	317.3	93.0	59.9	
ACPSB 510PP	439.5	14,000 [23,786]	72	22.2	479.4	140.5	256.3	75.1	56.7	452.1	132.5	245.7	72.0	61.3	427.5	125.3	237.1	69.5	66.5	
			67	19.4	439.5	128.8	319.7	93.7	55.6	412.5	120.9	308.1	90.3	60.0	388.6	113.9	298.2	87.4	65.2	
			62	16.7	403.0	118.1	380.1	111.4	54.6	382.2	112.0	370.2	108.5	59.1	357.9	104.9	357.9	104.9	64.1	
ACPSB 570PP	484.5	15,000 [25,485]	72	22.2	527.9	154.7	278.8	81.7	63.6	496.5	145.5	266.5	78.1	68.8	456.6	133.8	276.7	81.1	80.1	
			67	19.4	484.5	142.0	348.0	102.0	62.2	454.8	133.3	335.1	98.2	67.3	427.5	125.3	323.8	94.9	73.1	
			62	16.7	445.6	130.6	413.9	121.3	60.7	422.1	123.7	402.6	118.0	66.1	396.1	116.1	390.0	114.3	71.8	
ACPSB 640PP	577.7	16,000 [27,184]	72	22.2	638.8	187.2	337.1	98.8	77.5	608.7	178.3	324.5	95.1	82.9	570.9	167.3	308.8	90.5	88.9	
			67	19.4	577.7	169.3	410.5	120.3	75.9	549.0	160.9	398.5	116.8	81.2	518.6	151.9	385.9	113.1	87.3	
			62	16.7	533.7	156.4	489.3	143.4	74.8	506.7	148.5	476.0	139.5	80.1	477.7	140.0	461.7	135.3	86.1	
ACPSB 700PP	617.6	17,200 [29,223]	72	22.2	683.1	200.1	356.6	104.5	84.7	644.2	188.8	341.2	100.0	90.6	609.7	178.6	329.3	96.5	97.4	
			67	19.4	617.6	181.0	440.2	129.0	82.7	587.2	172.0	427.5	125.3	88.7	554.5	162.5	414.2	121.4	95.4	
			62	16.7	573.2	167.9	527.5	154.6	81.4	544.6	159.6	513.5	150.5	87.3	508.1	148.9	477.7	140.0	100.3	
ACPSB 760PP	659.6	18,000 [30,582]	72	22.2	726.4	212.8	378.1	110.8	90.7	689.3	202.0	363.1	106.4	97.3	649.3	190.2	348.7	102.2	104.6	
			67	19.4	659.6	193.3	466.1	136.6	88.5	627.2	183.8	453.1	132.8	95.1	592.0	173.5	438.5	128.5	102.4	
			62	16.7	613.2	179.7	558.6	163.7	87.1	583.1	170.8	543.9	159.4	93.6	555.8	162.8	520.0	152.4	110.7	
ACPSB 800PP	724.4	19,600 [33,300]	72	22.2	803.2	235.3	418.0	122.5	88.1	765.3	224.2	402.6	118.0	94.9	717.9	210.3	383.2	112.3	102.6	
			67	19.4	724.4	212.2	508.8	149.1	86.1	688.9	201.8	494.1	144.8	92.9	650.7	190.7	478.4	140.2	100.6	
			62	16.7	669.1	196.0	606.3	177.6	84.8	635.3	186.1	590.0	172.9	91.6	596.1	174.7	551.4	161.6	118.4	
ACPSB 890PP	805.6	21,000 [35,679]	72	22.2	889.2	260.5	464.4	136.1	9.1	845.9	247.8	446.6	130.9	105.7	792.3	232.1	424.8	124.5	114.3	
			67	19.4	805.6	236.0	566.1	165.9	95.5	765.3	224.2	549.4	161.0	103.3	722.0	211.5	531.3	155.7	111.9	
			62	16.7	746.2	218.6	675.3	197.9	93.9	708.4	207.6	656.8	192.4	101.6	660.6	193.6	603.9	176.9	118.6	
ACPSB 960PP	866.7	23,000 [39,077]	72	22.2	959.2	281.0	502.9	147.3	105.9	912.1	267.2	483.5	141.7	114.5	852.4	249.8	459.3	134.6	124.0	
			67	19.4	866.7	253.9	612.5	179.5	103.3	821.6	240.7	594.1	174.1	111.7	774.9	227.0	574.6	168.4	121.4	
			62	16.7	800.8	234.6	730.2	213.9	101.5	758.9	222.4	709.7	207.9	109.9	716.2	209.8	662.0	194.0	126.2	
ACPSB 1020PP	934.6	25,800 [43,834]	72	22.2	1034.6	303.1	540.1	158.2	135.8	988.2	289.5	521.4	152.8	144.1	927.1	271.6	496.8	145.6	153.4	
			67	19.4	934.6	273.8	659.9	193.4	133.5	890.9	261.0	642.2	188.2	141.7	843.1	247.0	622.4	182.4	151.1	
			62	16.7	865.0	253.4	787.9	230.9	131.9	823.3	241.2	767.7	224.9	140.1	780.4	228.7	722.0	211.5	134.3	
ACPSB 1140PP	1031.8	26,400 [44,854]	72	22.2	1129.4	330.9	587.9	172.3	147.0	1077.9	315.8	566.8	166.1	156.5	1020.9	299.1	542.9	159.1	167.2	
			67	19.4	1031.8	302.3	714.8	209.4	144.6	977.6	286.4	691.6	202.6	153.8	924.3	270.8	669.5	196.2	164.4	
			62	16.7	950.3	278.4	846.9	248.1	142.7	904.9	265.1	824.7	241.6	152.0	853.4	250.0	784.5	229.9	184.0	
ACPSB 1340PP	1199.7	32,000 [54,368]	72	22.2	1323.2	387.7	701.5	205.5	166.0	1259.4	369.0	674.9	197.7	177.6	1191.2	349.0	646.6	189.5	190.8	
			67	19.4	1199.7	351.5	848.3	248.6	162.7	1140.0	334.0	823.0	241.1	174.1	1075.5	315.1	796.1	233.3	187.1	
			62	16.7	1110.0	325.2	1008.6	295.5	160.3	1053.3	308.6	980.6	287.3	171.6	910.4	266.7	828.8	242.8	192.1	
ACPSB 1520PP	1365.2	36,000 [61,164]	72	22.2	1499.3	439.3	797.4	233.6	190.5	1419.8	416.0	764.0	223.9	204.2	1323.9	387.9	724.4	212.2	219.0	
			67	19.4	1365.2	400.0	973.1	285.1	185.8	1293.5	379.0	943.5	276.4	199.2	1216.1	356.3	911.0	266.9	214.3	
			62	16.7	1267.6	371.4	1161.5	340.3	182.4	1199.4	351.4	1127.7	330.4	195.7	1198.0	351.0	1129.4	330.9	240.3	

Notes: 1) Ratings are based on 80°F [27°C] air on evaporator dry bulb temperature.
 2) Ratings are gross capacities. For net capacity deduct evaporator blower motor heat.
 3) kW input shown in the table is total compressor(s) power input.

SYSTEM HEATING CAPACITY

PERFORMANCE DATA – HEAT PUMP HEATING MODE

Model	Std. Heating Capacity [MBH]	CFM [m³/h]	DB/WB	Ambient temperature								
				35			45			55		
				Total		KW	Total		KW	Total		KW
				MBH¹	kW¹	Input³	MBH¹	kW¹	Input³	MBH¹	kW¹	Input³
ACPRB 30PP	27.0	1,000 [1,699]	70/60	23.5	6.9	2.1	27.0	7.9	2.2	31.4	9.2	2.3
ACPSB 40PP	32.1	1,400 [2,379]	70/60	28.3	8.3	2.4	32.1	9.4	2.5	37.5	11.0	2.8
ACPSB 50PP	43.7	1,600 [2,718]	70/60	38.6	11.3	3.4	43.7	12.8	3.6	45.4	13.3	3.0
ACPSB 68PP	54.9	2,000 [3,398]	70/60	48.5	14.2	5.0	54.9	16.1	5.3	60.1	17.6	5.1
ACPSB 81PP	65.5	2,400 [4,078]	70/60	57.7	16.9	5.5	65.5	19.2	5.8	76.8	22.5	6.3
ACPSB 95PP	76.8	2,600 [4,417]	70/60	67.9	19.9	6.4	76.8	22.5	6.7	85.3	25.0	6.9
ACPSB 108PP	90.4	3,200 [5,437]	70/60	79.8	23.4	6.5	90.4	26.5	6.8	107.5	31.5	7.7
ACPSB 125PP	104.1	3,500 [5,947]	70/60	92.1	27.0	7.5	104.1	30.5	7.9	118.4	34.7	8.7
ACPSB 145PP	116.7	4,000 [6,796]	70/60	103.0	30.2	8.1	116.7	34.2	8.5	137.2	40.2	10.3
ACPSB 160PP	130.3	4,600 [7,815]	70/60	114.0	33.4	12.0	130.3	38.2	12.6	160.4	47.0	14.6
ACPSB 190PP	151.2	4,800 [8,155]	70/60	133.4	39.1	13.8	151.2	44.3	14.4	173.3	50.8	15.4
ACPSB 220PP	174.7	5,400 [9,175]	70/60	155.3	45.5	15.8	174.7	51.2	16.5	203.0	59.5	18.8
ACPSB 250PP	207.5	6,400 [10,874]	70/60	183.9	53.9	18.0	207.5	60.8	18.8	236.1	69.2	20.5
ACPSB 290PP	229.6	7,500 [12,743]	70/60	203.0	59.5	20.3	229.6	67.3	21.2	273.3	80.1	24.2
ACPSB 320PP	261.0	8,000 [13,592]	70/60	228.6	67.0	23.1	261.0	76.5	24.3	320.1	93.8	28.2
ACPSB 380PP	306.4	9,200 [15,631]	70/60	270.9	79.4	27.8	306.4	89.8	29.1	351.1	102.9	31.2
ACPSB 435PP	347.0	11,500 [19,539]	70/60	306.4	89.8	31.3	347.0	101.7	32.7	405.7	118.9	37.6
ACPSB 480PP	377.4	12,000 [20,388]	70/60	331.7	97.2	36.3	377.4	110.6	38.3	462.3	135.5	44.8
ACPSB 510PP	399.6	14,000 [23,786]	70/60	352.5	103.3	38.7	399.6	117.1	40.5	499.5	146.4	49.3
ACPSB 570PP	446.3	15,000 [25,485]	70/60	395.1	115.8	43.9	446.3	130.8	46.0	533.0	156.2	52.8
ACPSB 640PP	496.5	16,000 [27,184]	70/60	435.0	127.5	48.5	496.5	145.5	50.7	601.9	176.4	61.1
ACPSB 700PP	557.5	17,200 [29,223]	70/60	490.3	143.7	54.3	557.5	163.3	56.7	686.2	201.1	69.1
ACPSB 760PP	594.4	18,000 [30,582]	70/60	525.1	153.9	59.1	594.4	174.2	61.6	730.5	214.0	75.5
ACPSB 800PP	644.6	19,600 [33,300]	70/60	564.7	165.5	59.1	644.6	188.9	62.1	818.2	239.7	80.1
ACPSB 890PP	723.0	21,000 [35,679]	70/60	636.4	186.5	65.7	723.0	211.8	68.8	880.7	258.0	82.4
ACPSB 960PP	760.9	23,000 [39,077]	70/60	668.1	195.8	70.7	760.9	222.9	74.0	944.8	276.8	88.5
ACPSB 1020PP	809.4	25,800 [43,834]	70/60	709.7	207.9	77.5	809.4	237.2	81.1	1017.8	298.2	102.4
ACPSB 1140PP	912.4	26,400 [44,854]	70/60	804.6	235.7	86.8	912.4	267.3	91.0	1098.7	321.9	109.0
ACPSB 1340PP	1023.3	32,000 [54,368]	70/60	907.3	265.8	97.5	1023.3	299.8	101.9	1202.1	352.2	116.3
ACPSB 1520PP	1139.7	36,000 [61,164]	70/60	1046.8	306.7	111.0	1139.7	333.9	114.2	1382.9	405.2	133.1

- Notes:
- 1) Ratings are based on 70°F [21°C] air on evaporator dry bulb temperature.
 - 2) Ratings are gross capacities. For net capacity, deduct evaporator blower motor heat.
 - 3) kW input shown in the table is total compressor(s) power input.



Product that perform...By people who care

BLOWER PERFORMANCE

EVAPORATOR

Model	Airflow on Evaporator		Blower Size Standard (Qty)		External Static Pressure - in WG [Pa]									
					0.5 [125]		1.0 [249]		1.5 [374]		2.0 [498]			
	CFM	m ³ /h	50 Hz	60 Hz	RPM	Motor Hp (Qty)	RPM	Motor Hp (Qty)	RPM	Motor Hp	RPM	Motor Hp		
ACPRB 30P	1,000	1,699	241-181 (1)	241-181 (1)	1,300	315W	Not Applicable	Not Applicable	Not Applicable	Not Applicable	Not Applicable	Not Applicable		
ACPSB 40P	1,400	2,379	241-181 (1)	241-181 (1)	1,300	315W								
ACPSB 50P	1,600	2,718	241-241 (1)	241-241 (1)	1,300	315W								
ACPSB 68P	2,000	3,398	270-270 (1)	270-270 (1)	1,200	750W								
ACPSB 81P	2,400	4,078	270-270 (1)	270-270 (1)	1,250	750W								
ACPSB 95P	2,600	4,417	270-270 (1)	270-270 (1)	1,300	750W								
ACPSB 108P	3,200	5,437	270-270 (2)	270-270 (2)	1,250	600W (2)							1,400*	750W (2)*
ACPSB 125P	3,500	5,947	270-270 (2)	270-270 (2)	1,300	600W (2)							1,400*	750W (2)*
ACPSB 145P	4,000	6,796	270-270 (2)	270-270 (2)	1,200	750W (2)							1,400*	750W (2)*
ACPSB 160P	4,600	7,815	15-15	15x15			861	3.0	987	3.0	1,102	4.0		
ACPSB 190P	4,800	8,155	15-15	15x15			888	3.0	1,010	4.0	1,122	4.0		
ACPSB 220P	5,400	9,175	15-15	15x15			919	4.0	1,033	4.0	1,140	5.5		
ACPSB 250P	6,400	10,874	18-13	18x13			767	4.0	849	5.5	934	5.5		
ACPSB 290P	7,500	12,743	18-13	18x13			791	5.5	873	7.5	945	7.5		
ACPSB 320P	8,000	13,592	18-18	18x18			753	5.5	848	7.5	931	7.5		
ACPSB 380P	9,200	15,631	18-18	18x18			771	7.5	858	7.5	942	10.0		
ACPSB 435P	11,500	19,539	450	450x450			790	10.0	865	10.0	935	15.0		
ACPSB 480P	12,000	20,388	500	500x500			686	7.5	768	10.0	843	10.0		
ACPSB 510P	14,000	23,786	500	500x500			761	15.0	832	15.0	901	15.0		
ACPSB 570P	15,000	25,485	500	500x500			791	15.0	858	15.0	924	20.0		
ACPSB 640P	16,000	27,184	560	560x560			640	10.0	706	15.0	769	15.0		
ACPSB 700P	17,200	29,223	560	560x560			690	15.0	752	15.0	811	20.0		
ACPSB 760P	18,000	30,582	560	560x560			710	15.0	770	20.0	827	20.0		
ACPSB 800P	19,600	33,301	630	630x630			587	15.0	648	20.0	705	20.0		
ACPSB 890P	21,000	35,679	630	630x630			609	20.0	666	20.0	721	20.0		
ACPSB 960P	23,000	39,077	630	630x630			630	20.0	677	25.0	729	25.0		
ACPSB 1020P	25,800	43,834	710	710x710			526	20.0	575	20.0	622	25.0		
ACPSB 1140P	26,400	44,854	710	710x710			518	20.0	568	20.0	615	25.0		
ACPSB 1340P	32,000	54,368	800	800x800			430	25.0	484	25.0	527	30.0		
ACPSB 1520P	36,000	61,164	800	800x800			470	30.0	517	40.0	558	40.0		

- Notes: 1) Direct driven fan for model 30 to 145. Motor power in Watt.
 2) Please consult factory for areas shaded in grey and ESP exceeds the above table.
 3) * Applicable to 50Hz only.
 4) Model 30P & 50P are not offered for installation in US region.

LIMITS AND CORRECTION FACTORS

OPERATING LIMITS

LIMITATION (AIR TEMPERATURE °F[°C])

		DB	WB
Indoor	Max.	95 [35]	72 [22]
	Min.	66 [19]	57 [14]
Outdoor	Max.	115 [46] (Cooling Mode) 75 [24] (Heating Mode For Heat Pump Model)	-
	Min.	66 [19] (Standard) 45 [7] (With Low Ambient Kit) 45 [7] Heat Pump 15 [-9] Heat Pump Low (liquid receiver is required)	-

CORRECTION FACTORS

To correct for variation in air flow, use this multiplier

Air Flow Variation	Total Capacity	Sensible Capacity
0.9	0.980	0.950
1.0	1.000	1.000
1.1	1.015	1.045

To correct for altitude, use this multiplier

Air Above Sea Level - ft	Cooling Capacity
0	1.00
2000	0.98
3000	0.97
4000	0.96
5000	0.95
6000	0.93

DIMENSIONAL DATA

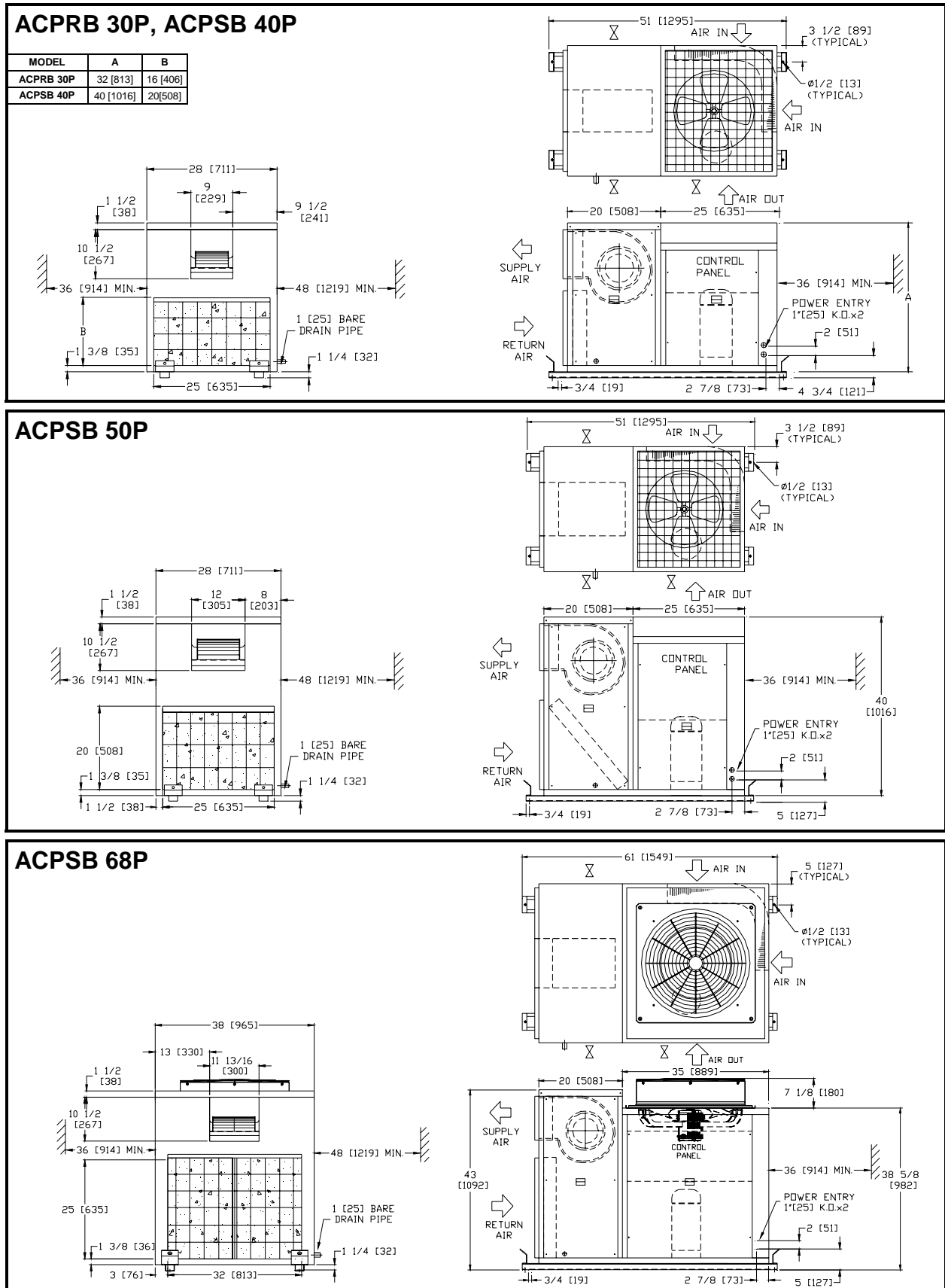

Note: All dimensions are in inches [mm].

DIMENSIONAL DATA

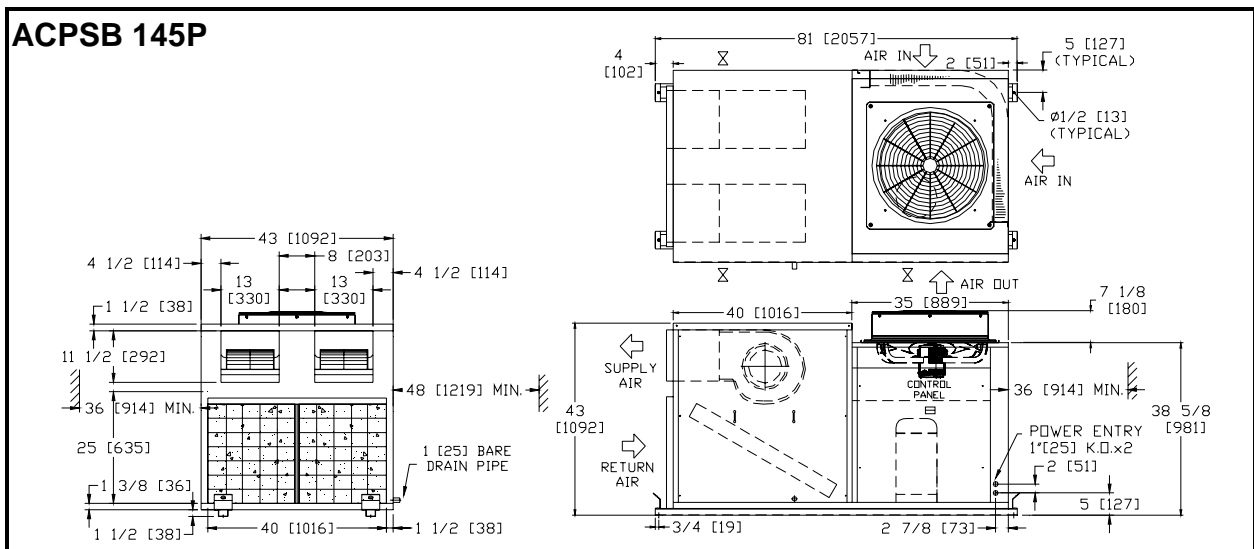
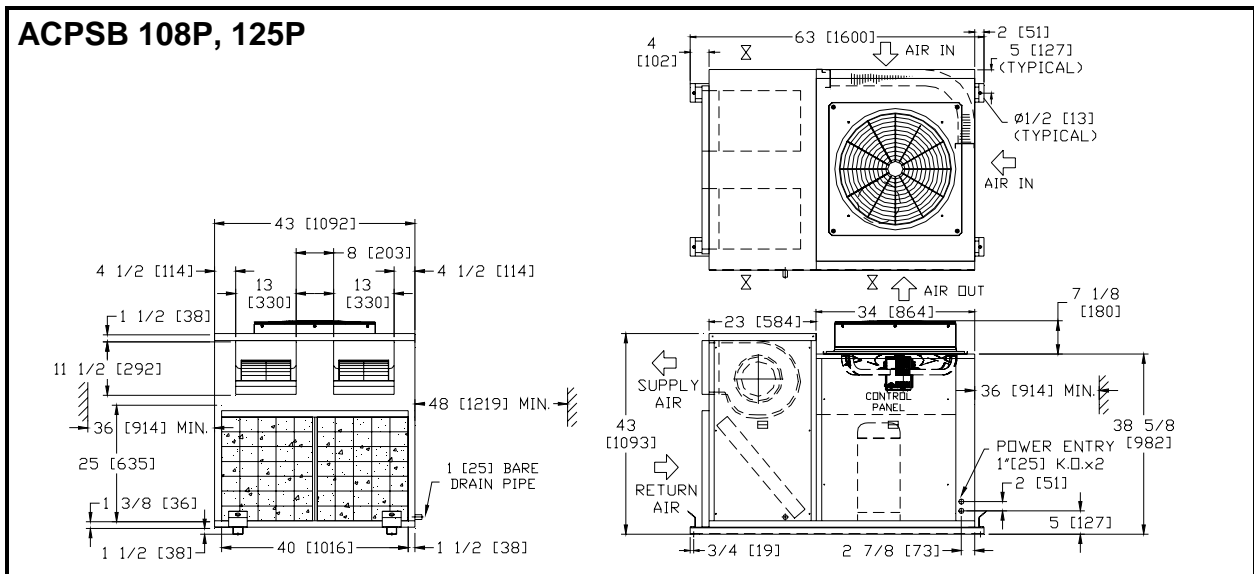
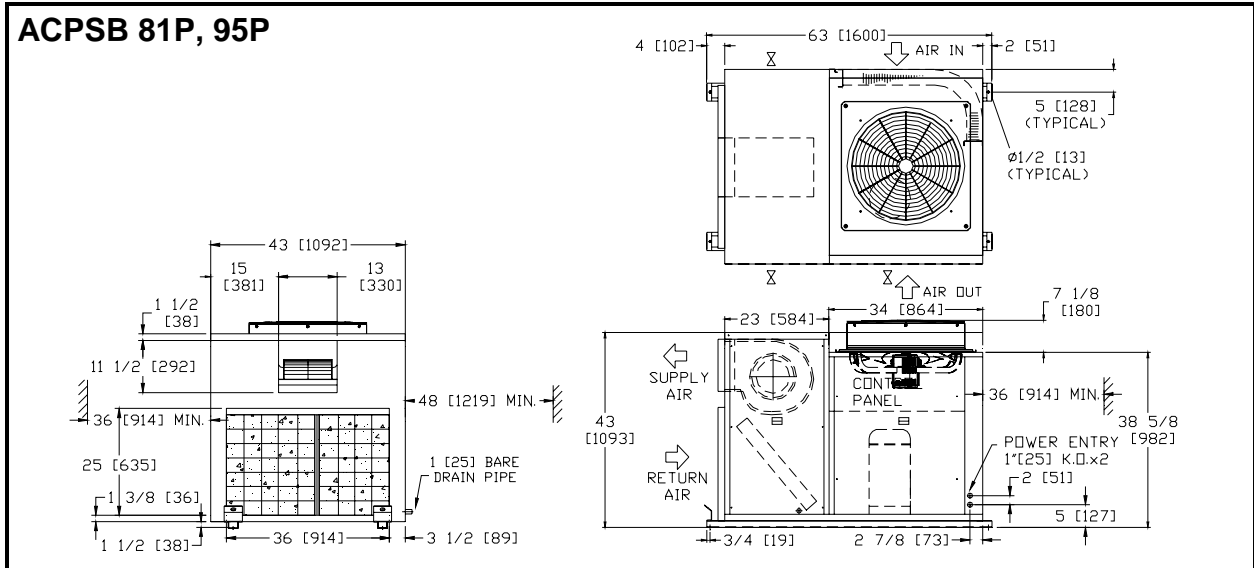

Note: All dimensions are in inches [mm].

DIMENSIONAL DATA

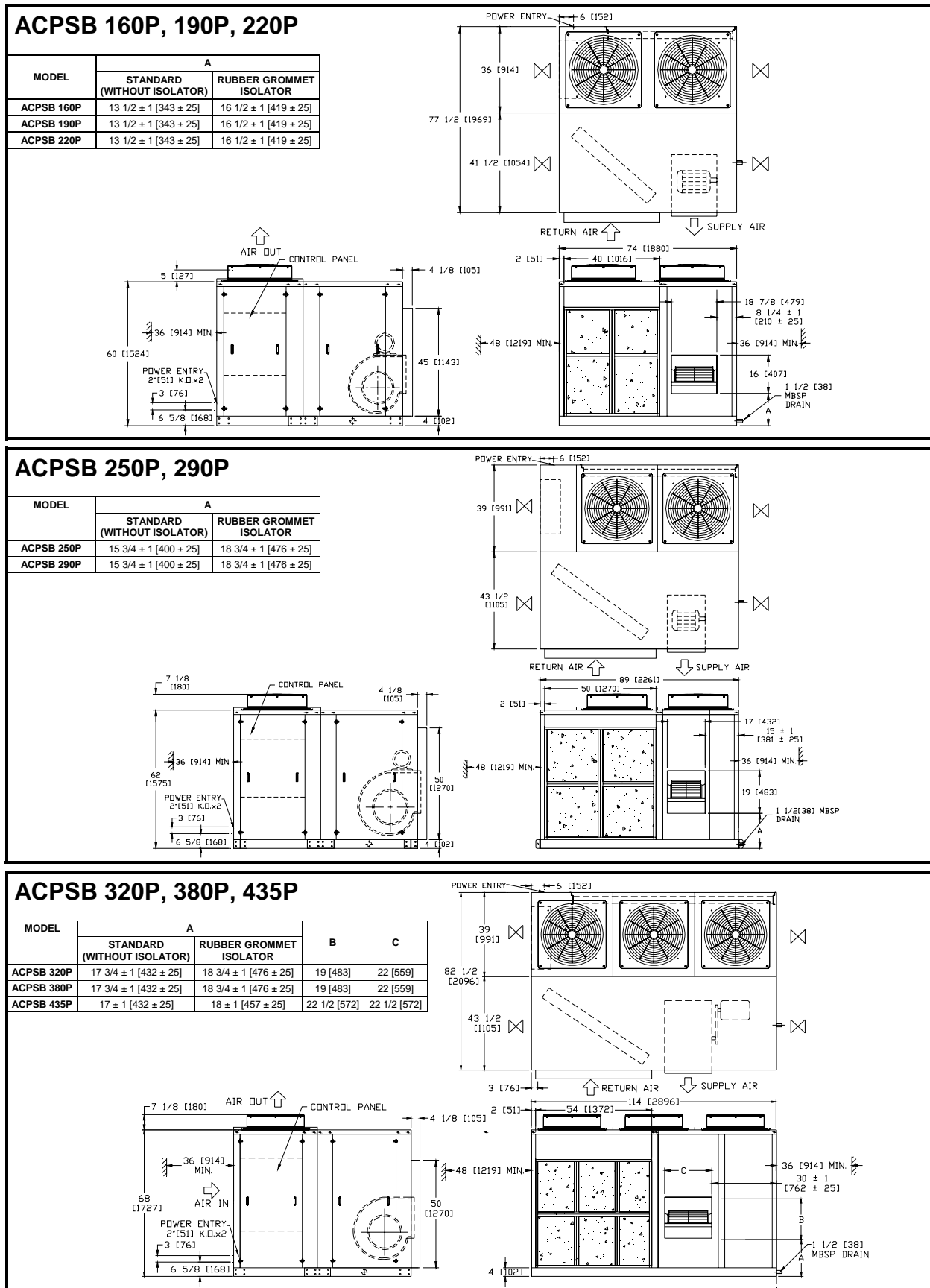

Note: All dimensions are in inches [mm].

DIMENSIONAL DATA

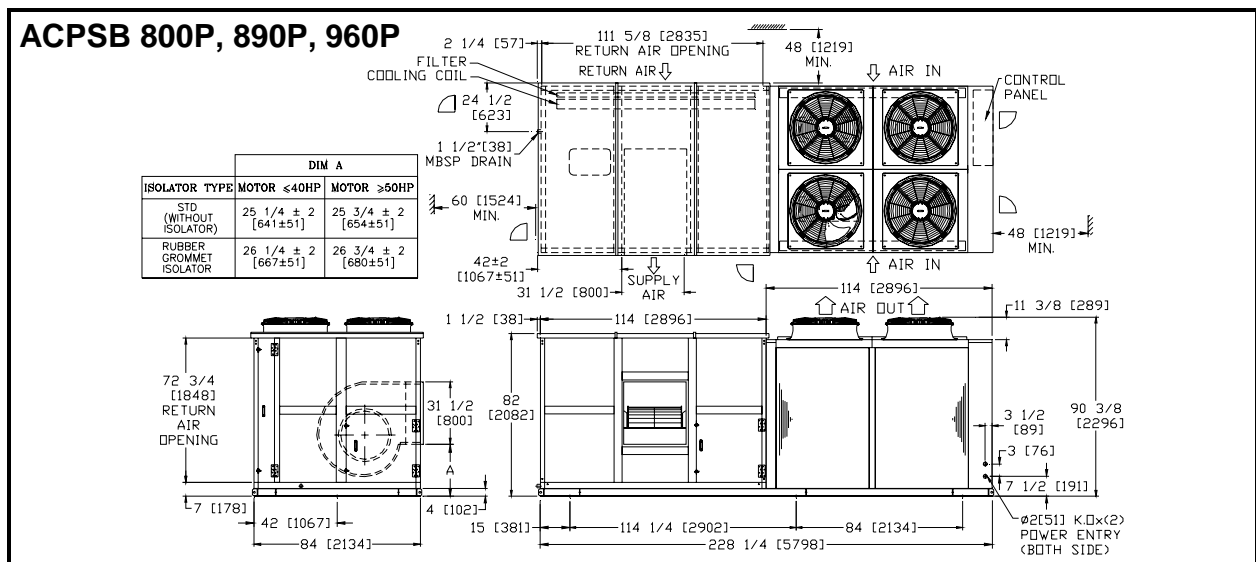
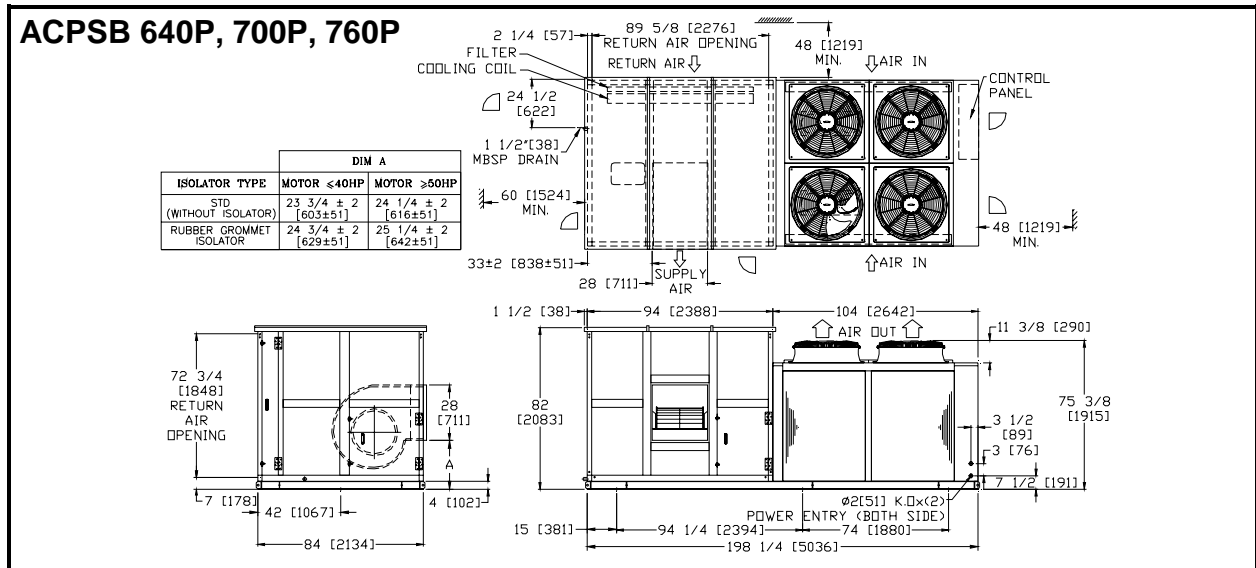
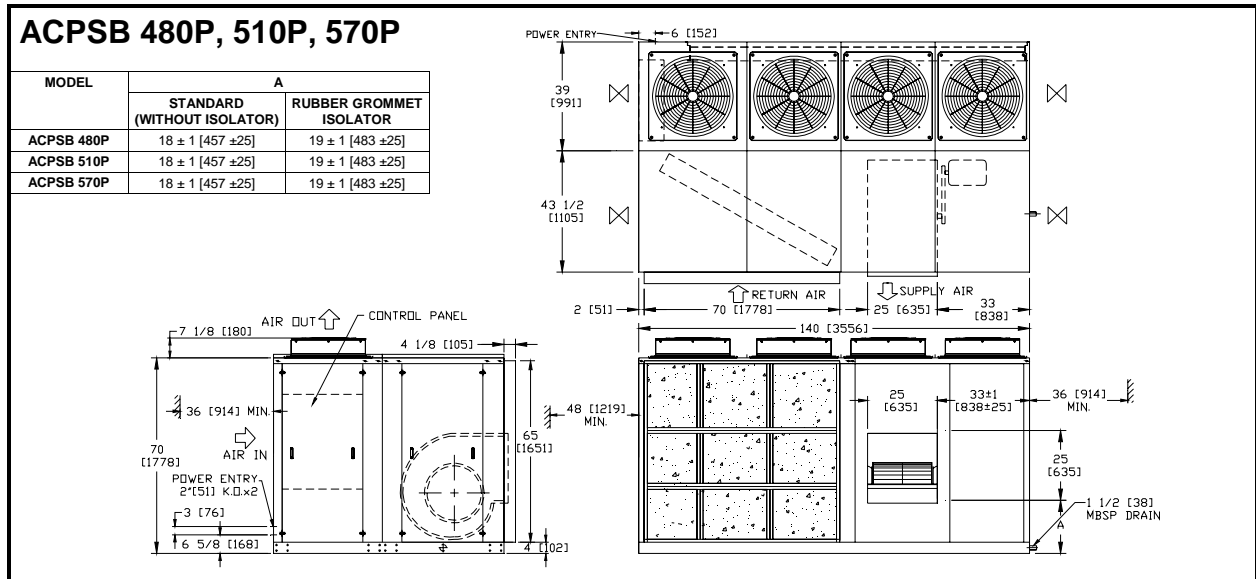

Note: All dimensions are in inches [mm].

DIMENSIONAL DATA

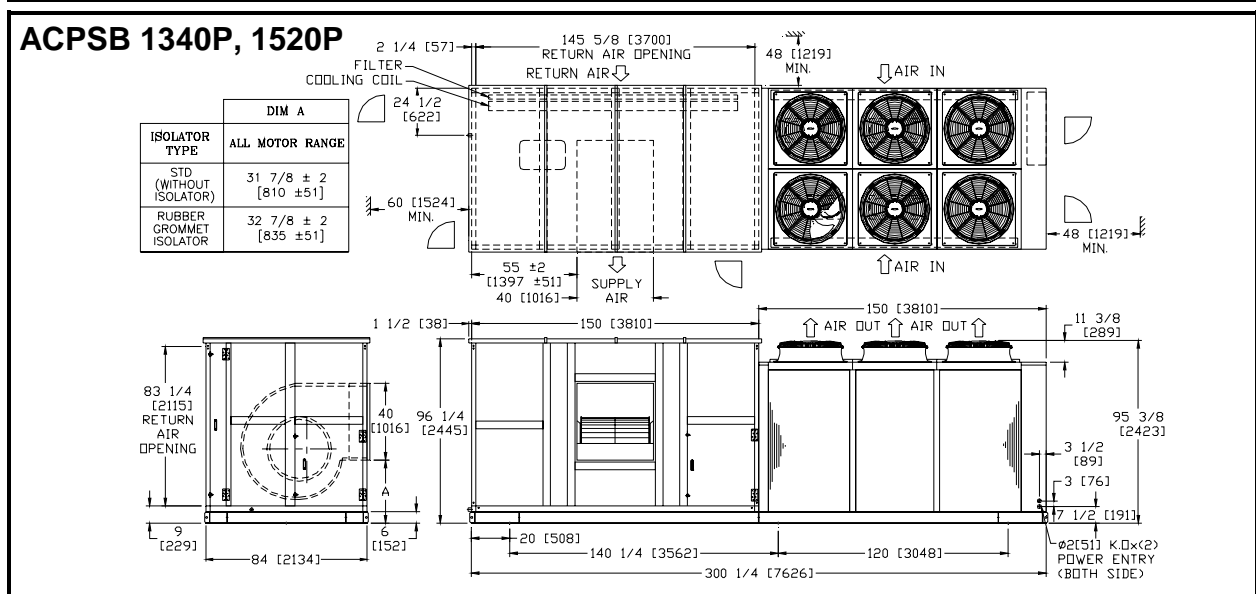
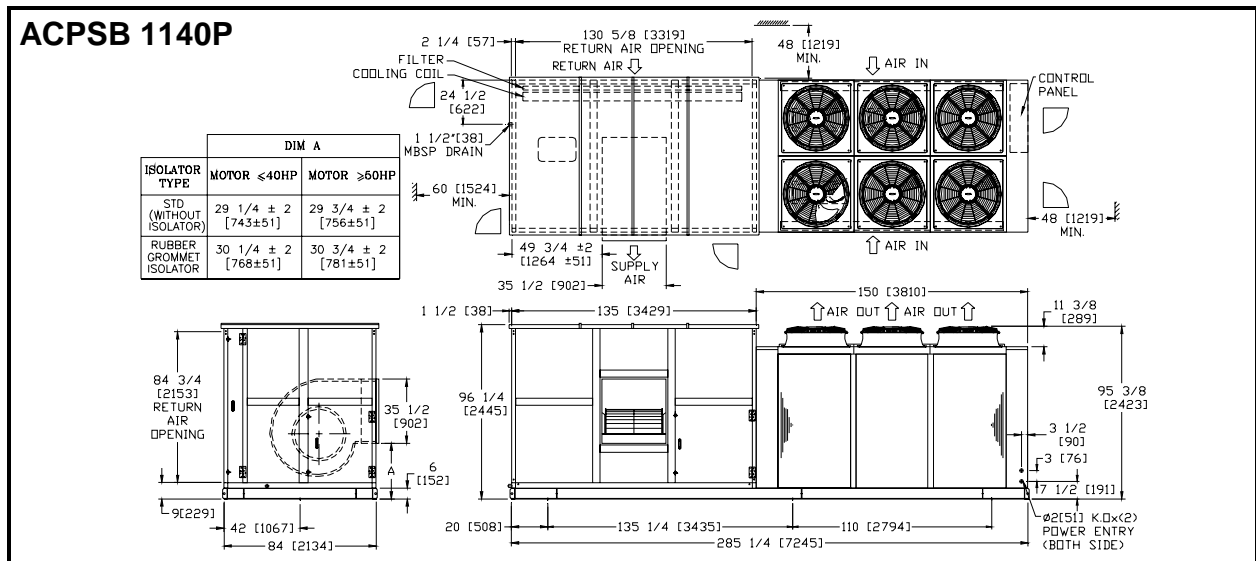
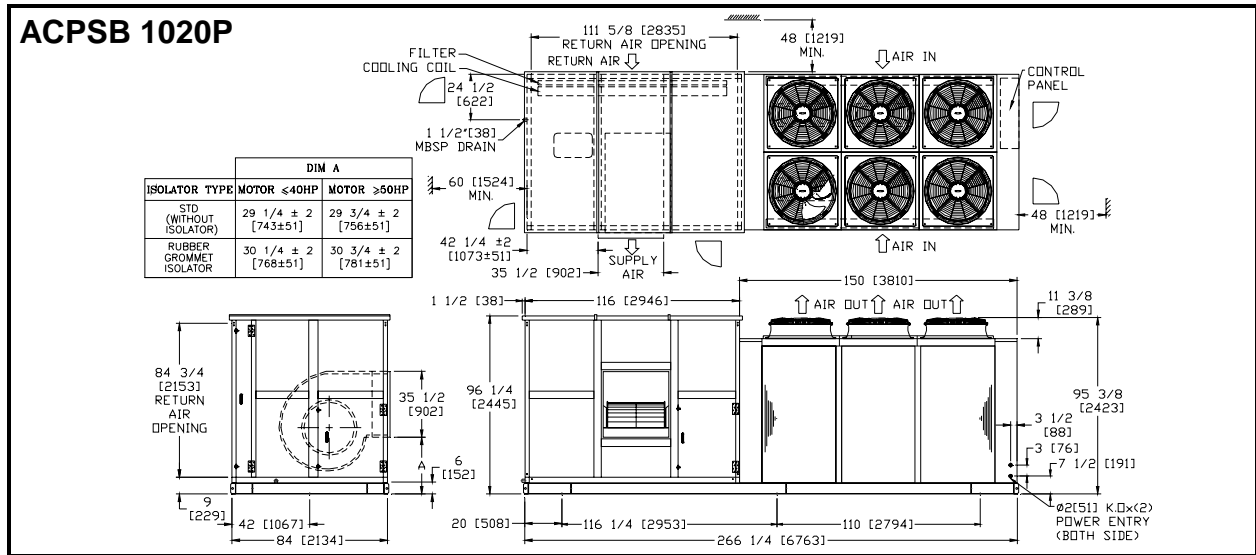

Note: All dimensions are in inches [mm].

GUIDE SPECIFICATIONS

1 GENERAL

Air cooled packaged unit shall include compressor(s), evaporator and condenser coils with fans, refrigeration piping, electrical components and enclosing cabinet in one piece. The units shall be factory assembled, internally wired, fully refrigerant charged with R410A and are suitable for outdoor installation on ground level with ducted system. The units shall be capable to operate up to 115°F [46°C] ambient temperature without failure.

2 CABINET

The unit cabinet shall be constructed from heavy gauge galvanized steel with epoxy painted for excellent finished, weatherability and corrosion resistance up to 1000 hours salt spray test according to ASTM B-117. Evaporator section shall be of 13mm [1/2 inch] (model ACPSB Series 30P to 145P) and 25mm [1 inch] (model ACPSB Series 160P and above) thick single skin and lined with minimum 2lbs/ft³ [32kg/m³] density having thermal conductivity of 0.0346W/m.K [0.24Btu.in/ft².h.°F] acoustical fiberglass insulation. The insulation shall have fire resistant of Class O (BS 476 Part 6, 7). Access doors shall be provided for easy service and maintenance of unit internal parts.

3 COMPRESSOR & REFRIGERATION PIPING

Compressor(s) shall be scroll, refrigerant gas cooled and mounted on the base via vibration isolators. 1, 2, 3 or 4 refrigeration circuits shall be piped with copper tubing and include expansion valve with external equalizer, filter dryer, sight glass, pressure fittings of manual reset high pressure control and auto reset low pressure safety cutouts as well as charging/access ports in each circuit. The compressors comply with the internationally recognized standards CE and UL.

4 EVAPORATOR COIL

Evaporator coil shall be of draw through air design for uniform air distribution. The evaporator coil shall be quality construction of staggered row of 3/8"OD (model ACPSB Series 30 to 570P) and 1/2"OD (model ACPSB 640 and above) seamless copper tube, mechanically bonded to aluminium fins with galvanized coil plates. The coil shall be factory leak and pressure tested to 650psig [45 bar] under water. A galvanized and painted drain pan shall be provided to cover the entire coil area. The drain pan shall be designed to incorporate sloped gutter for complete condensate removal.

5 EVAPORATOR BLOWER AND MOTOR

Evaporator blower shall be direct-driven (model ACPSB Series 30 to 145P) and belt driven (model ACPSB Series 160P and above), double-inlet-double-width (DIDW) forward curved. All blowers are statically and dynamically balanced to ensure quiet operation and smooth performance. Heavy-duty V-belt fan drive with cast iron pulleys keyed and secured to the blower shaft shall be provided (model ACPSB Series 160P and above).

Motors shall be of totally enclosed fan cooled (TEFC) with IP55 enclosure rating, 4-poles with class F insulation. Motors shall be mounted to an adjustable motor frame. Motor pulleys shall be cast iron, keyed and secured to the motor shaft (model ACPSB Series 160P and above).

6 CONDENSER COIL

Condenser coil shall be air cooled with integral sub-cooling circuit, constructed from staggered row of 3/8"OD inner grooved seamless copper tube, mechanically bonded to aluminium fins with galvanized coil plates. The coil shall be factory leak and pressure tested to 650psig [45 bar] under water.

7 CONDENSER FAN AND MOTOR

Condenser fan shall be direct driven propeller type discharging air vertically upward. Condenser fans shall be constructed of corrosion resistant blades and are statically and dynamically balanced. Condenser fan motors shall be of totally enclosed fan cooled (TEFC) with IP55 enclosure rating, 6-poles with class F insulation and wired to unit control panel (model ACPSB 68P and above). The condenser fan assembly shall be provided with heavy gauge and rust resistant steel wire fan guard.

8 FILTERS

Units shall be provided with 1" (model ACPSB Series 30P to 145P) and 2" (model ACPSB Series 160P and above) thick washable pleated filters having average arrestance efficiency of 70% (model ACPSB Series 30P to 145P) and 75% (model ACPSB Series 160P and above) as per ASHRAE Standard 52.1 (or equivalent) with side loading.

9 CONTROL PANEL

The unit mounted control panel enclosure shall be constructed from heavy gauge galvanized steel with epoxy painted for excellent finished, weatherability and corrosion resistance. The enclosure shall conform to IP54. Hinged and lock type access door shall be provided for easy access and security. The control panel shall be wired without starter and control.

10 Crankcase Heater

Crankcase Heater shall be provided to prevent liquid refrigerant migration and condensation of refrigerant in the crankcase of the compressor when the unit is off.

11 OPTIONS

11.1 Stainless Steel Drain Pan

A stainless steel condensate drain pan shall be provided for the evaporator section in lieu of standard galvanized and painted drain pan.

11.2 Hot Gas Bypass

The refrigerant circuit (applicable to 'first in last out' refrigeration system only) shall be provided with a hot gas bypass system for low load and low ambient condition (evaporator freeze protection).

GUIDE SPECIFICATIONS

11.3 Evaporator Coil Fin Materials

In lieu of standard aluminium fin, alternative fin material and/or protective coating include,

- ✿ Hydrophilic coated aluminium fin
- ✿ Copper Fin
- ✿ Aluminium fin with Airestec coating
- ✿ Copper fin with Airestec coating

11.4 Condenser Coil Fin Materials

In lieu of standard aluminium fin, alternative fin material and/or protective coating include,

- ✿ Hydrophilic coated aluminium fin
- ✿ Copper Fin
- ✿ Aluminium fin with Airestec coating
- ✿ Copper fin with Airestec coating

11.5 Condenser Coil Guard

Powder coated wire mesh guard shall be provided for better condenser coil protection.

11.6 High and Low Pressure Gauges

Each compressor is provided with unit mounted pressure gauges to monitor high and low side operating pressure.

11.7 Discharge / Suction / Liquid Line Service Valves

Service valves shall be provided at each refrigerant lines for service convenience.

11.8 Closed Cell Elastomer Insulation

½" (model ACPSB 30P to 145P) and 1" (model ACPSB 160P and above) thick closed cell elastomer insulation (Insulflex®) shall be provided in lieu of standard fiberglass insulation. Closed cell elastomer insulation shall comply Class O (BS476 Part 6) and Class 1 (BS476 Part 7) fire resistant standard.

11.9 1" Double Wall Fiberglass Casing (Evaporator Section)

1" double wall fiberglass casing shall be provided in lieu of single skin fiberglass casing (model ACPSB Series 160P and above).

11.10 1" Double Wall Polyurethane Casing (Evaporator Section)

1" double wall polyurethane casing shall be provided in lieu of single skin fiberglass casing (model ACPSB Series 640P and above) for superior thermal insulation.

11.11 Liquid Line Solenoid Valve (LLSV)

Factory fitted liquid line solenoid valve shall be provided for each refrigeration circuit.

11.12 Evaporator Blower Isolator

Rubber or spring isolator shall be provided to dampen vibration caused by motor and blower (model ACPSB Series 160P and above).

11.13 Replaceable Core Filter Drier

Replaceable filter core drier shall be provided in lieu of standard filter drier for the convenience of filter drier's core replacement.

11.45 Stainless Steel Fasteners

Stainless steel fasteners shall be provided in lieu of standard fasteners for corrosion resistance application.

11.15 Suction accumulator

Suction accumulator shall be provided to prevent liquid refrigerant migration to compressor.

11.16 C-Channel Structural Steel Base

C-channel structural steel base shall be provided in lieu of standard GI steel base for better structural support (model ACPSB Series 160 to 570P)

11.17 Belt Guard

Belt guard shall be provided for belt and pulley's non- contact exposure.

11.18 Electric Heater

Electric heater shall be provided for heating purpose.

11.19 Electronic Expansion Valve (EEV)

In lieu of standard thermal expansion valve, EEV shall be provided for precise superheat control (energy saving).

11.20 IEC DOL (Non UL)

The unit mounted control panel enclosure shall be constructed from heavy gauge galvanized steel with epoxy painted for excellent finished, weatherability and corrosion resistance. The enclosure shall conform to IP54. Hinged and lock type access door shall be provided for easy access and security. The control panel shall be factory wired and shall include compressor, evaporator fan motor and condenser fan motor circuit breaker and contactors, compressor and evaporator fan motor thermal overload relays, anti-recycling time delay relay, control circuit fuse, power and control circuit terminal blocks and features 230V controls with 380-415V/3PH/50HZ (+Neutral) power supply or 115V/230V/24V controls with 208V-230V/380/460V-3PH-60HZ power supply.

11.21 Micro Vision Controller

Micro Vision a flexible and advance programmable microprocessor controller designed specifically for the applications and precise control of Dunham-Bush packaged units. The controller is provided with a set of terminals that connected to various devices such as temperature sensors, refrigerant pressure safety switches, solenoid valves, control relays and etc. The unit algorithm program and operating parameters are stored in flash-memory that does not require a back-up battery.

11.22 Indicating Lights

Indication provided for high-pressure trip and compressor run.

GUIDE SPECIFICATIONS

11.23 UVR/Phase Failure Protect

Phase Failure Relay is provided for over voltage, under voltage and phase loss protection.

11.24 IP55 Control Panel

In lieu of standard control panel, IP55 Control Panel with double layer access door shall be design in according to IP55 standard is provided

11.25 Vision 2020i

The unit shall be provided with Vision 2020i control system with the following features,

- ✿ The control algorithm and parameters shall be stored in flash memory and EPROM of the controller and shall retain even in the event of power failures, without requiring a backup battery
- ✿ PGD Display
- ✿ Built in memory for data logging
- ✿ Temperature and humidity controlled
- ✿ Configurable by user
- ✿ Alarm status/display
- ✿ Analog input/output display
- ✿ Digital input/output status
- ✿ Remote start/stop input
- ✿ Digital input for customer input alarm
- ✿ General alarm output (dry contact)
- ✿ Self-diagnostics
- ✿ Security password access with multiple access level for advanced settings
- ✿ Unit status display

11.26 MODBUS RS485

MODBUS card can be added for BMS communication. VISION 2020i controller must be selected for this features.

11.27 Lock Out Stop

Emergency stop switch provided for Blower Fan.

11.28 Differential Pressure Switch for Evaporator Blower

Differential pressure switch provided to interlock with the control circuit.

11.29 Voltmeter

Voltmeter and selector switch provided for voltage display

11.30 Ammeter

Ammeter and selector switch provided for current display.

11.31 Anti Recycle Timer

Additional timer is added to prevent the compressor from starting for a period of time after it stops last.

11.32 Electric Heater Starter

Contact and circuit breaker provided for electric heater.

11.33 Low Ambient Kit

Fan cycling for better performance during low ambient.

11.34 Compressor Soft Start

Soft-Starter for compressors to reduce the starting current.

11.35 Door Interlock Main Incoming Isolator

Incoming Isolator is provided for isolate the main incoming power supply to the unit.

11.36 Hinged Access Door

Hinged type access door shall be provided for model ACPSB Series 640P and above.

11.37 Star Delta Starter Evaporator Motor

Star Delta starting method available for Evaporator motor.

11.38 Nominal Evaporator Motor Soft Starter

Soft-Starter available to reduce the starting current for Nominal Evaporator motor.

11.39 Max Evaporator Motor Soft Starter

Soft-Starter available to reduce the starting current for Maximum sized Evaporator motor.

11.40 VFD for Condenser Motor

Variable Frequency Drive (VFD) on condenser fan motors (base fans) with pressure transducer added for more accurate control.

11.41 VFD for Evaporator Motor Nominal HP

Variable Frequency Drive (VFD) on Nominal Evaporator motor with pressure transducer.

11.42 VFD for Evaporator Motor Max HP

Variable Frequency Drive (VFD) on Maximum Evaporator motor with pressure transducer.

11.43 VFD Box

Control panel to mount Variable Frequency Drive (VFD).



Malaysia

Lot 5755-6,
Kidamai Industrial Park,
Bukit Angkat,
43000 Kajang,
Selangor, Malaysia

Tel: +603-8924 9000
Fax: +603-8739 5020

China

No. 1 Dunham-Bush Road,
Laishan District,
Yantai,
Shandong Province,
China 264003

Tel: +86-535-739 7888
Fax: +86-535-739 7999

United Kingdom

8 Downley Road,
Havant,
Hampshire,
England PO9 2JD

Tel : +44-23-9247 7700
Fax: +44-23-9245 0396

United States of America

11948 Miramar Parkway
Miramar, Florida 33025
United States of America

Tel: +305-883 0655
Fax: +305-883 4467

United Arab Emirates

Office # 2606,
Fortune Executive Towers,
Cluster T1, Jumeirah Lake Tower
Dubai, UAE

Tel: +971-4-443 9207
Fax: +971-4-443 9208

South Africa

No. 57 Sovereign Drive
Route 21 Corporate Park
Irene, Pretoria
South Africa

Tel: +27-12-345 4202
Fax: +27-12-345 4203

India

957D, 9th Floor, Tower B-1,
Spaze i-Tech Park, Sohna Road,
Sector-49, Gurugram,
Haryana-122018, India

Tel: +91-124-414 4430

Indonesia

The Vida Building 7th Floor
Jl. Raya Perjuangan
No. 8 Kebon Jeruk
Jakarta 11530, Indonesia

Tel: +62-21-2977 8100
Fax: +62-21-2977 8001

Thailand

1 QHouse Lumpini,
27th Floor, South Sathorn Road,
Tungmahamek, Sathorn,
Bangkok Thailand 10120

Tel: +66-0-2610 3749
Fax: +66-0-2610 3601

Singapore

2 Kallang Pudding Road
#07-07 Mactech Building
Singapore 349307

Tel: +65-6842 2012
Fax: +65-6842 2013

Vietnam

10th Floor, Nam A Bank Tower,
201-203 Cach Mang Thang 8 Street,
District 3, Ho Chi Minh City,
Vietnam

Tel: +84-8-6290 3108
Fax: +84-8-6290 3109

DUNHAM-BUSH®

info@dunham-bush.com
www.dunham-bush.com



Products that perform...By people who care

Manufacturer reserves the right to change specifications without prior notice.

M-S-0228C-1019