



ACHELOUS

Air Cooled Screw Chillers

AVX-A 50/60Hz

Cooling Capacity: 96 to 548 TR (338 to 1929 kW)



DUNHAM-BUSH®

Products that perform...By people who care

INTRODUCTION

For more than 100 years, Dunham-Bush has focused on innovative product development. Today, we provide a full portfolio of HVAC/R products from Fan Coil Units to large centrifugal chillers as well as many other innovative green solutions. Our commitment to innovation, matched with an aggressive attitude toward growth, makes Dunham-Bush a leader in global markets. Our product development is tailored to meet the specific needs of customers, building-by-building, country-by-country and region-by-region. No other HVAC/R manufacturer takes this approach to meeting your performance expectations.

The Dunham-Bush name is synonymous worldwide with the Rotary Screw Compressor Chillers technology. With over 45 years of proven experience and track records in manufacturing and installation of Rotary Screw Compressors and chillers, thousands of our Chillers have clocked more than 100,000 operating hours without any compressor tear-out or overhaul! As a pioneer and industry leader in the Rotary Screw compressor technology for HVAC/R systems, Dunham-Bush now introduces the Air Cooled Rotary Screw Flooded Chillers with unsurpassed performance and reliability.

ACHELOUS, AVX-A Air Cooled Screw Flooded Chillers, have a cooling capacity range from 96 to 548 TR [338 to 1929 kW] in 50/60Hz version using environmentally sound R134a refrigerant. The entire product line features high energy efficiency, installation ease, control flexibility, high reliability and advanced Vision 2020i controller. The AVX-A series are certified to AHRI Standard 550/590 and meets ASHRAE Standard 90.1-2016.

TABLE OF CONTENT

	Page No		Page No
Introduction	2	Sound Pressure Data	15
Nomenclature.....	2	Dimensional Data	16
General Characteristics	3	Floor Loading Diagram.....	23
Unit Features	3	Field Power & Control Wiring Schematic.....	26
Options And Accessories.....	6	Application Data	27
Operating Benefits	7	Minimum Clearance Requirements	30
Physical Specifications	9	Guide Specifications.....	31
Electrical Data.....	13		

NOMENCLATURE

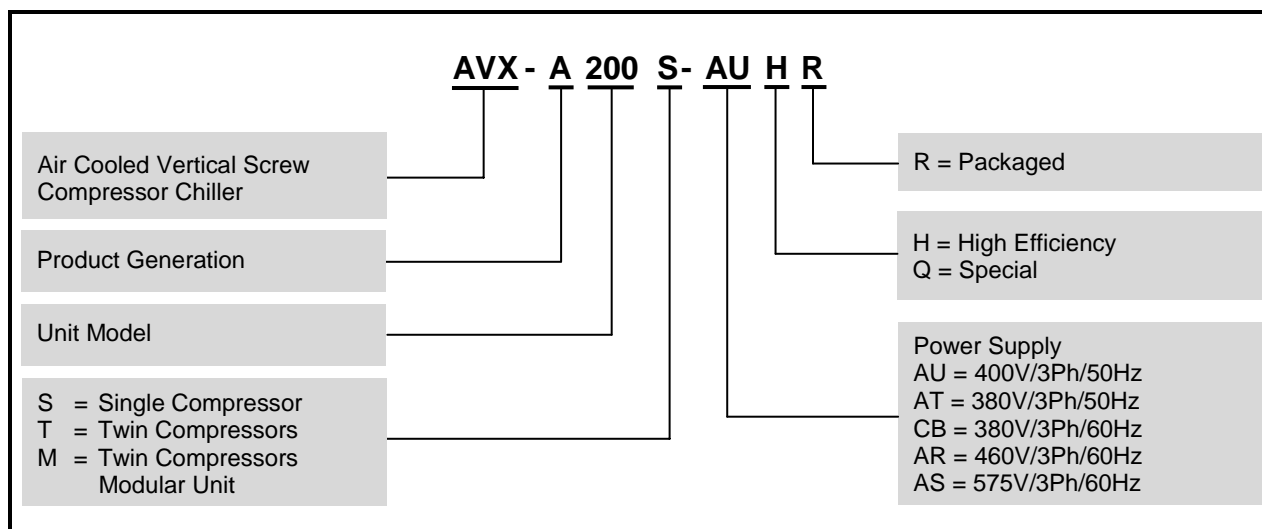

GENERAL CHARACTERISTICS

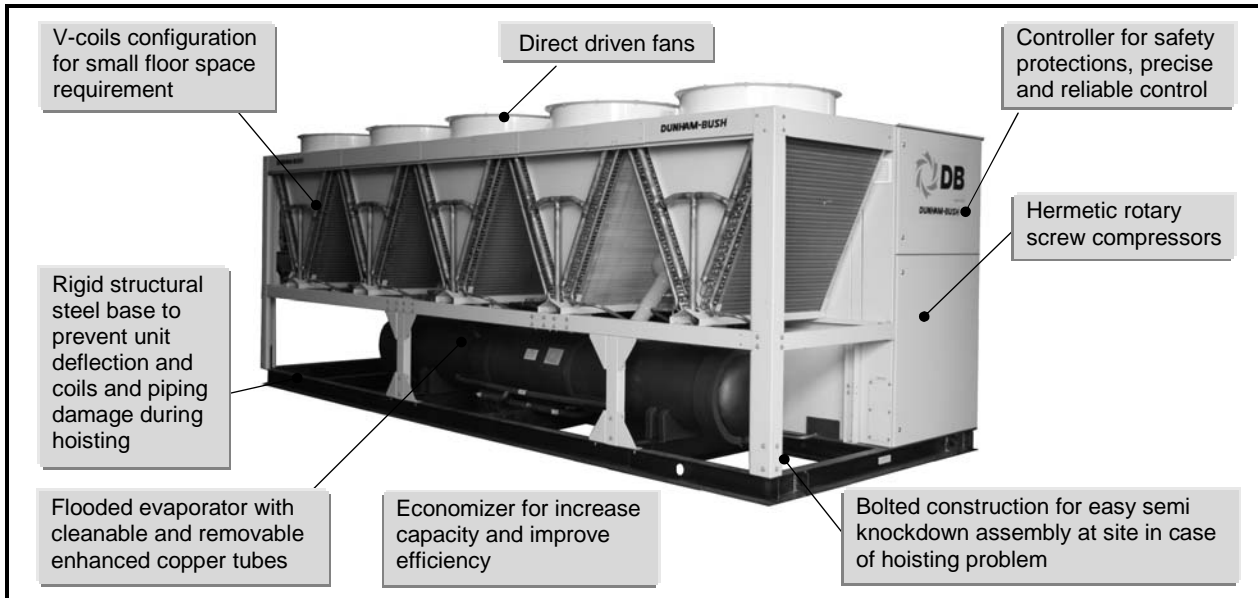

UNIT FEATURES

General

- ✦ 40 models from 96 to 548 TR [338 to 1929 kW] in accordance with AHRI standard conditions
- ✦ Multiple compressors models with independent refrigerant system per compressor provide redundancy, and superior part load efficiency
- ✦ The unit is designed to operate with R134a, the environment friendly refrigerant with zero **ODP** (Ozone Depletion Potential)
- ✦ Standard unit operating ambient temperature, 45~125°F [7~52°C]
- ✦ Units are ETL listed for North America and Canada regions.

Compressor

- ✦ New generation of Dunham-Bush MSC Vertical Screw Compressors with Unique Patented Twin Screw compressor technology, offers further improved reliability and stability, with lower sound level
- ✦ Optimized oil management with up to 2 integral oil separators. Multi-layered mesh element effectively separates oil from the gas stream
- ✦ No external oil pump required
- ✦ Patented screw profile design which is specially made for R134a application, to assure operation at highest efficiencies
- ✦ Optimized volume ratio, VI port position and geometry for best efficiency
- ✦ Consistent loading and unloading with hydraulically actuated slide valve mechanism; a rugged and trouble-free design
- ✦ Hermetic design eliminates casing leakage, with no requirement for internal parts service, no periodic compressor tear down and overhaul

- ✦ Direct driven design eliminates gear set; improve efficiency and reliability
- ✦ Discharge service valves is provided to each compressor for the ease of servicing

Evaporator

- ✦ Shell-and-tube flooded type heat exchanger
- ✦ Integral finned copper tubes to maximized heat transfer area
- ✦ Cleanable copper tubes for maintaining high efficiency
- ✦ Removable water heads for easy service
- ✦ Victaulic groove water connection comply to ANSI/AWWA C-606
- ✦ Standard with 1" thick closed cell insulation
- ✦ Standard relief valve(s) – 3/4" [19mm] FPT
- ✦ Pressure test up to 220psig for refrigerant side, and 195psig for water side
- ✦ Isolation valves for refrigerant filter dryers are provided to allow filter core replacement without pump down the chiller. This greatly improve the servicing expenses and time

Condenser and Fans

- ✦ Constructed with seamless inner-grooved copper tubes expanded into die-formed aluminum slit fins in staggered configuration
- ✦ Leak and pressure test at 450psig [31bar]
- ✦ "V" coil design to increase condensing surface area to maximized heat rejection
- ✦ "V" coils arrangement with internal baffle for fan cycling and staging
- ✦ IP55 fan motors for outdoor applications

UNIT FEATURES

Electronic Expansion Valve

- ✿ Advanced electronic expansion valve (EEV) is used for precise control of liquid refrigerant flow into the evaporator
- ✿ Evaporation of liquid refrigerant in evaporator is controlled at precise level for optimum performance

Economizer

- ✿ The economizer circuit consists of plate type heat exchanger, expansion valve and solenoid valve
- ✿ Liquid refrigerant is sub-cooled at economizer before entering the evaporator; the flash refrigerant from economizer is fed into vapor injection port of the compressor
- ✿ The economizer increased cooling capacity by means of the sub-cooling

Control Panel

- ✿ Weather tight electrical enclosure fabricated by heavy gauge sheet steel with powder coated baked finishing
- ✿ Single point power connection for all models, except below models which are modular units with dual power connection points as standard:
 - AVX-A 450M (50Hz)
 - AVX-A 490M (50Hz)
 - AVX-A 520M (50Hz)
 - AVX-A 440M (60Hz)
 - AVX-A 470M (60Hz)
 - AVX-A 540M (60Hz)
- ✿ Unit mounted reduced inrush starter for compressor motors
- ✿ Circuit breaker for compressors and condenser fan motors
- ✿ Step down transformer for power supply to control circuit
- ✿ Main power supply monitoring module. Protection on under or over voltage, phase reversal, phase losses and imbalance
- ✿ Unit mounted Remote/Off/Local (R/O/L) selector, an operation and servicing friendly feature
- ✿ Overload protection relay for compressors
- ✿ Vision 2020i – the state-of-art Dunham-Bush proactive advanced controller that adapts to any abnormal operating conditions and for safety protections
- ✿ Chilled water pump control

VISION 2020i CONTROLLER

Vision 2020i a flexible and advance programmable microprocessor controller designed specifically for the application and precise control of Dunham-Bush Rotary Screw compressor chillers.

The controller is provided with a set of terminals that connect to various devices such as temperature sensors, pressure and current transducers, solenoid valves, compressors and fans starters, control relays, etc. Three sizes of controller boards are provided to handle different number of input and output

requirements: DB5-S small, DB5-M medium and DB5-L large board.

The unit algorithm program and operating parameters are stored in FLASH-MEMORY that does not require a back-up battery. The program can be loaded through PC or programming key.

Vision 2020i controller is equipped with a user friendly terminal with a semi-graphic display and dedicated keys that provides easy access to the unit operating conditions, control set points and alarm histories.

Each unit's controller can be configured and connected to the Dunham-Bush DBLAN network that allows multiple chillers sequencing control without additional controller or panel. Dunham-Bush DBLAN is the local area network made up of several chillers' controller.



Display and User Terminal

The Vision 2020i controller is designed to work with a user friendly back-lit 132 by 64 pixels DBGe Semi-Graphic Display panel connected with the controller through a telephone cable. The terminal display allows carrying out of the unit operations, and also allows the unit working conditions, compressor run times and alarm history to be displayed. Set points and other parameters can be modified via the user terminal. The display has an automatic self-test of the controller on system start-up. Multiple messages will be displayed automatically by scrolling from each message to the next. All of these messages are spelled out in English on the display terminal.

Easily accessible measurements include:

- ✿ Leaving and entering chilled water temperature
- ✿ Rate of Change for leaving chilled water temperature
- ✿ Evaporator and condenser pressure
- ✿ Compressor discharge temperature and superheat
- ✿ Ambient temperature
- ✿ Current drawn by each compressor
- ✿ Compressor capacity (percentage of FLA, Full Load Amps)
- ✿ Run hours of each compressor
- ✿ Number of starts of each compressor
- ✿ Electronic Expansion Valve (EEV) Opening Percentage
- ✿ Compressors and condenser fans motors status
- ✿ Oil Level Status, Water Flow Switch Status, Remote Start/Stop Command Status

UNIT FEATURES

Capacity Control

Leaving chilled water temperature control is accomplished by entering the water temperature setpoint and placing the controller in automatic control. Vision 2020i monitors all control functions and moves the compressors slide valve to the required position to match the building cooling load demand.

The compressor ramp (loading) cycle is programmable and may be set for specific building requirements. Remote adjustment of the leaving chilled water setpoint is accomplished either through High Level Interfacing (HLI) via BMS communication, or Low Level Interfacing (LLI) via an external hardwired, 4 to 20mA chilled water reset control signal. Remote reset of compressor current limiting function can be accomplished in a similar fashion.

System Control

The unit may be started or stopped manually, or through the use of an external signal from a Building Automation System. In addition, the controller may be programmed with seven-day operating cycle or other Dunham-Bush control packages may start and stop the system through inter-connecting wiring.

System Protection

The following system protection controls will automatically act to ensure system reliability:

- ✿ Low evaporator pressure
- ✿ High condenser pressure
- ✿ Freeze protection
- ✿ Low suction-discharge pressure differential
- ✿ Low compressor oil level
- ✿ Compressor run error
- ✿ Power loss
- ✿ Chilled water flow loss
- ✿ Sensor error
- ✿ Compressor over current
- ✿ Compressor Anti-recycle
- ✿ High motor temperature
- ✿ Compressor overload

The controller can retain up to 99 alarm histories complete with time of failure together with data stamping on critical sensor readings in an alarm condition. This tool will aid service technicians in troubleshooting tasks enabling downtime and nuisance trip-outs to be minimized.

Remote Monitoring And Control (Option)

Dunham-Bush, the leader of HVAC solution provider understands the arising focus on chiller plant performance and optimization. Several solutions as below are offered to the building owner to achieved optimized chiller plant room controls, operation and performance.

Dunham-Bush Chiller Plant Manager (CPM)

DB Chiller Plant Manager (**CPM**) is a trustworthy and headache-free solution for building owners and users on chiller plant control and automation system. **CPM**'s advanced controllers monitor and control equipments in chiller plant such as chillers, primary and secondary chilled water pumps, variable frequency drives (VFD), motorized valves, bypass modulating valves, and etc. Field devices such as flow meters, BTU meters, digital power meters, sensors & transducers can be interfaced with **CPM** via HLI or LLI. CPM controls chillers and pumps sequencing, as well as lead-lag, duty-standby and alarm changeover operations.

NetVisorPRO – Monitoring software of **CPM** system which allows system monitoring, historical trending, and alarm logging to be carry out at a PC terminal. Graphical animations on system operation, temperature and flow rate trend graphs, historical data and alarm history logs, settings changes are all available with **NetVisorPRO**.

Chiller plantroom control and automation by Dunham-Bush **CPM** provides the owners with a chiller system in stable operation, optimized performance and energy efficiency.

DB-LAN Master Slave Sequencing Control (MSS)

In a chiller system with multiple Dunham-Bush chillers, Vision 2020i controller of each chiller can be connected to the DB-LAN network via a communication bus without additional controller, to enable Master-Slave Sequencing Control of this chiller system. **MSS** will stage in/out chiller in operation to match building required cooling capacity. Chiller Lead-lag, duty-standby and alarm changeover controls are come with **MSS**, as well as the chilled water pumps control. Each **MSS** DB-LAN network can be connected up to 8 numbers of chillers.

Building Management System (BMS) Communication

Vision 2020i is able to communicate to BMS through the add-on communication card via various common protocols as:

- ✿ Modbus RTU RS485, ModBus TCP/IP
- ✿ BACnet over IP, MS/TP, or PTP
- ✿ LONworks FTT10

OPTIONS AND ACCESSORIES

- ❖ **Heat Recovery** – The hot gas desuperheater; a shell-and-tube heat exchanger that reclaims ‘waste’ heat from compressor to produce hot water up to 55°C
- ❖ **Condenser Corrosion Protection** – Copper (CU) fins or Hydrophilic coated fins are provided to give better corrosion protection. **DB-COAT**, the post-coated solution for condenser coil to provide extensive corrosion protection for harsh environment
- ❖ **Hotgas Bypass** – To maintain unit operation below minimum unloaded capacity
- ❖ **Service valve** – Compressor suction service valve is supplied to further isolate the compressor from evaporator
- ❖ **Flanged Semi-hermetic Compressor** – Semi hermetic compressor is available on request
- ❖ **Low Ambient Operation (LA 1)** – Variable frequency drive (VFD) is incorporated to the condenser fan motor to allow unit operation down to 14°F [-10°C] ambient temperature
- ❖ **Extra Low Ambient Operation (LA 2)** – Add-on low ambient kit to allow unit operation down to -20°F [-29°C] ambient temperature
- ❖ **Double Thick Insulation** – Evaporator with double thick 2” [50mm] closed cell insulation, for extra resistance to condensation
- ❖ **Evaporator Anti-Freeze Protection** – When chiller is not operating at ambient temperature 32°F [0°C] or below, the immersion heater and circulating pump will be in operation to prevent water freezing in evaporator
- ❖ **Protective Grille for Condenser Coil** – To protect condenser coil from unauthorized access
- ❖ **Evaporator Flanged Water Connection** – Flanged water connection is available as option
- ❖ **250PSIG [1.7MPa] Working Pressure Vessel** – Evaporator with 250psig [1.7MPa] working pressure on water side
- ❖ **Compressor Acoustic Jacket** - Compressor Acoustic Jacket can be added to further reduce the sound level
- ❖ **Dual Mode Operation** – The unit with dual mode operation can deliver chilled fluid temperature down to 18°F [-7.8°C] during ice making mode. Units with Dual Mode Operation is used for Ice Thermal Storage System
- ❖ **Low Temp. Operation** – The unit with Low Temp. Operation can deliver chilled fluid temperature down to 18°F [-7.8°C] for process cooling application
- ❖ **ASME/ PED/ CRN Compliance** – Evaporator with ASME/ PED/ CRN approval is available
- ❖ **CE Compliance** – Unit with CE compliance is available on request
- ❖ **BMS Communication** – Various add-on communication cards provide BMS communication via common protocols: Modbus RTU RS485 / TCP/IP, LONworks FTT10, BACnet over IP / MSTP / PTP
- ❖ **Modular Piping Kit** – Evaporator’s Interconnecting pipe and accessories for module chillers for convenient assembly at site.

Electrical And Controls

- ❖ **Unit Mounted Main Disconnect Switch** – Non-fused disconnect switch with external lockable handle is furnished to isolate unit main incoming power supply for servicing.
- ❖ **Single Power Connection Point** – Quick and easy field installation with one main power supply termination. Applicable to below models only:
 - AVX-A 450M (50Hz) - AVX-A 440M (60Hz)
 - AVX-A 490M (50Hz) - AVX-A 470M (60Hz)
 - AVX-A 520M (50Hz) - AVX-A 540M (60Hz)
- ❖ **Softstarter For Compressor Motors** – Solid State starter comes with bypass contactor to reduced mechanical stress and inrush current at compressor start-up
- ❖ **Ground Fault Interrupt (GFI)** – Provides equipment with ground fault protection
- ❖ **Ammeter/ Voltmeter** – Analog ammeter and voltmeter with 3 phase selector switch for indication, located inside the control panel
- ❖ **Chilled Water Reset/ Demand Limiting** – Low level interfacing with Building Automation System (BAS). Chilled Water Reset allows controlled temperature setpoint to be reset by a 4-20mA signal from BAS; while Demand Limiting will limit the maximum current drawn by the compressors by 4-20mA signal from BAS
- ❖ **System Voltage Measurement** – System voltage option is a safety features to protect system from high and low voltage due to unbalance power supply. The controller will trigger alarm high or low voltage and cut-off running system
- ❖ **IP55 Control Panel** – IP55 rated control panel can be supplied for harsh working environment

Factory Supplied, Field Installed By Customer

- ❖ **Evaporator Water Flow Switch**– Flow switch to be installed at evaporator outlet piping as safety interlock to evaporator water flow status. Three options are available: Weather tight flow switch with CE mark; NEMA 1 and NEMA 4 rated flow switch
- ❖ **Rubber-In-Shear Isolators** – Designed for ease of installation. These one-piece molded rubber isolators are applicable for most installations
- ❖ **Spring Isolators** – These housed spring assemblies have a neoprene friction pad at the bottom to prevent the passage of noise, and a spring locking levering bolt at the top. Neoprene inserts prevent contact between the steel upper and lower housings. Suitable for more critical application as compared to rubber-in-shear isolator
- ❖ **DB-LAN Master Slave Sequencing Control (MSS)** – Pre-programmed at factory; field supplied and installed inter-connection wiring between chillers to provide communication bus among chillers’ controllers to enable Master-Slave Sequencing Control
- ❖ **Chiller Plant Manager (CPM)** – Factory supplied control panel; field supplied and installed interconnection wiring and field devices; for complete chiller plantroom automation

OPTIONS AND ACCESSORIES

DB DIRECTOR (For US Region Only)

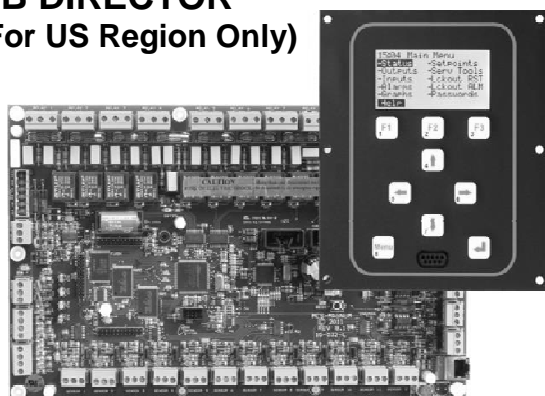

DB-Director control system is offered to US region as an option to Vision 2020i control system.

DB-Director is a rugged microprocessor based controller designed for the HVAC/R applications. DB-Director provides flexibility with setpoints and control options that can be selected prior to commissioning a system or when the unit is live and functioning. Displays, alarms and other interfaces are accomplished in a clear and simple language that informs the user as to the status of the controller.

DB-Director is equipped with 128 x 64 pixels monochrome graphics LCD display with 2.8" diagonal viewing area, and 9 dedicated keys that enable user to access information, base on security level of the password. The user terminal is allows displaying and easy access to the unit working conditions, compressor run times, alarm histories and modify the parameters. Multiple messages will be displayed by automatically scrolling from each message to the next. All of these messages are spelled out in English language on the display terminal.

The display also has an automatically self-test of the controller on system start-up. For more detail operation of the DB-Director keypad, please refer to the Unit operation Manual.

Remote Monitoring For DB-Director

DB-Director is equipped with RS485 and Ethernet communication ports as standard. This user friendly design allows Building Management System (BMS) to interface directly with the chiller via either of Modbus RTU, Modbus IP, or BACnet IP communication protocol.

LONworks or BACnet MSTP communication protocol can be established with installation of external adapter.

OPERATING BENEFITS

EFFICIENCY AND RELIABILITY

Energy Efficiency

- ✦ Designed to provide the greatest amount of cooling for the least power input over the entire operating range of your building
- ✦ Delivers outstanding efficiency and total energy savings through the utilization of economizer cycle and advanced controller staging; to produce greater capacity with fewer compressors
- ✦ Maximized performance through optimized components matching and multiple compressors
- ✦ High efficiency oil recovery system guarantees removal of oil carried over in the refrigerant and maintains the heat exchangers at their maximum efficiency at both full and part load

Refrigerant Compatibility

- ✦ Designed to operate with environmentally sound and economically smart HFC-134a with proven efficiency and reliability
- ✦ Consult Factory for use of other HFC refrigerants.

Flooded Evaporator

- ✦ Flooded evaporator design that fully utilized and maximized the heat transfer area available in the evaporator; operates with lower suction superheat, smaller evaporator approach. These have greatly improved efficiency of chiller with flooded evaporator.

- ✦ Flooded evaporator water heads can be removed easily without dismantling the chilled water piping connections, for inspection and for mechanical tubes cleaning with brushes or auto-brush. This will enable low tube fouling factor in the evaporator to be ensured, thus maintaining system efficiency

Operational Advantages

- ✦ Dramatic payback in reduced maintenance and overhaul costs both in downtime and in labor expenditures
- ✦ Ease of troubleshooting through controller retention of monitored functions

Factory Testing

- ✦ Each chiller undergoes the factory testing prior to unit shipment. This assures consistencies of workmanship at highest quality
- ✦ Thus, all units shipped are completely factory tested; charged and adjusted according to the design parameters, for ease of installation and minimal field start-up adjustments

Control Flexibility

- ✦ Controller-based with DDC controller (direct digital control) features precise push button control over every aspect of operation with built-in standard features that maximized energy savings on start-up and throughout the life of your equipment

OPERATING BENEFITS

- ❁ Ensured uniform compressor loading and optimal energy efficiency through controller to controls which utilize pressure transducers to measure evaporator and condenser pressure
- ❁ Lower energy costs resulting from automatic load monitoring and increased accuracy and efficiency in compressor staging
- ❁ Various communication options for remote monitoring of the unit operation
- ❁ Proactive control anticipates problems and takes corrective action before they occur. Controls will unload compressor(s) if head or suction pressure approach limits. This will enable unit to stay on line while warning operator of potential problems
- ❁ Stable and efficient operation with precise chilled water temperature control. Chilled water temperature is controlled at ± 0.8 °F [0.5 °C] range for your comfort cooling, with best energy saving

REFRIGERATION CYCLE

Dunham-Bush rotary screw air cooled chillers are designed for efficiency and reliability. The rotary screw compressor is a positive displacement, variable capacity compressor that will allow operation over a wide variety of conditions.

The refrigerant management system is shown in the refrigerant cycle diagram.

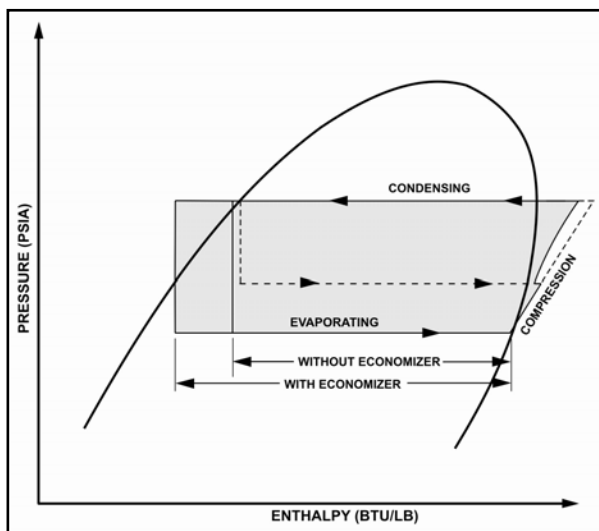

Liquid refrigerant enters the flooded evaporator uniformly where it absorbs heat from water flowing through the evaporator tubes. The vaporized refrigerant is then drawn into the suction port of the compressor where the positive displacement compression begins.

This partially compressed gas is then combined with additional gas from the vapor injection port at an intermediate pressure. Compressed gaseous refrigerant is then discharged into the integral oil separator where oil, which is contained in the refrigerant vapor, is removed and returned to the compressor oil sump.

Fully compressed and superheated refrigerant is then discharged into the condenser, where air is being drawn through the condenser tube by the propeller fan cools and condenses the refrigerant. The liquid

refrigerant then passes through the economizer. A portion of liquid refrigerant is tapped passes through the expansion valve back into the economizer for further subcooling of main liquid refrigerant flow.

The gaseous refrigerant is then drawn out of the economizer and into the vapor injection port of the compressor. The remaining subcooled liquid refrigerant then passes through electronic expansion valve which reduces refrigerant pressure to evaporator levels where it is then distributed evenly into the evaporator.

With the additional subcooling, the enthalpy of the refrigerant flowing into the evaporator is reduced which increases the refrigeration effect and improves the efficiency of the refrigeration cycle.

Economizer/ Vapor Injection Cycle for Increase Capacity and Higher EER

The renowned Dunham-Bush screw compressor allows for economizer vapor injection cycle to be incorporated, increasing capacity by significantly with marginal increase in kW-input. Thus, unit EER is improved!

PART-LOAD PERFORMANCE

Through the use of economizer, electronic expansion valve and multiple compressors, Dunham-Bush air cooled chillers have some of the best part-load performance characteristics in the industry when measured in accordance with AHRI Standard 550/590.

In most cases, actual building system loads are significantly less than full load design conditions, therefore chillers operate at part load most of the time.

Dunham-Bush air cooled chillers combine the efficient operation of multiple compressors with an economizer cycle and advanced controller to yield the best total energy efficiency and significant operating saving under any load.

When specifying air conditioning equipment, it is important to consider the system load characteristics for the building application. In a typical city, the air conditioning load will vary according to changes in the ambient temperature. Weather data compiled over many years will predict the number of hours that equipment will operate at various load percentages.

The Air Conditioning and Refrigeration Institute (AHRI) has established a system, in AHRI Standard 550/590, for measuring total chiller performance over full and part-load conditions. It defines the Integrated Part-Load Value (IPLV) as an excellent method of comparing diverse types of equipment on an equal basis. The IPLV is a single number estimate of a chiller's power use weighted for the number of hours the unit might spend at each part-load point. IPLV's are based on Standard Rating Conditions.

The formula for calculating an IPLV is:

$$IPLV = \frac{1}{\frac{0.01}{A} + \frac{0.42}{B} + \frac{0.45}{C} + \frac{0.12}{D}}$$

where: **A= kW/ton at 100% load point**
B= kW/ton at 75% load point
C= kW/ton at 50% load point
D= kW/ton at 25% load point



PHYSICAL SPECIFICATIONS

50 Hz

Model AVX-A		95S	115S	135T	140S	170S	170T	185T	200S	220S	235T	250S
Cooling Capacity	TR	96.1	116.8	136.0	140.8	169.7	170.9	188.0	191.1	221.9	235.1	251.3
	kW	338	411	478	495	597	601	661	672	780	827	884
Power Input	kW	104.4	129.6	157.8	158.6	181.7	187.6	206.4	198.2	232.0	251.4	262.3
Energy efficiency	kW/TR	1.086	1.110	1.160	1.104	1.071	1.098	1.098	1.037	1.046	1.069	1.044
COP	kW _e /kW _i	3.237	3.170	3.031	3.185	3.285	3.204	3.203	3.391	3.364	3.289	3.370
Compressor												
Quantity		1	1	2	1	1	2	2	1	1	2	1
RPM		2950	2950	2950	2950	2950	2950	2950	2950	2950	2950	2950
Min. % Unit Capacity Reduction		25%	25%	12.5%	25%	25%	12.5%	12.5%	25%	25%	12.5%	25%
No. Of Refrigerant Circuit		1	1	2	1	1	2	2	1	1	2	1
Evaporator												
Model (Qty)		C4R (1)	1CR (1)	1DRT (1)	1DR (1)	2ER (1)	2ERT (1)	2FRT (1)	2FR (1)	EBR (1)	EBRT (1)	JCR (1)
Water Connector	inches	4	5	5	5	6	6	6	6	6	6	8
	mm	101.6	127	127	127	152.4	152.4	152.4	152.4	152.4	152.4	203.2
Nominal Water Flow	Usgpm	230.6	280.3	326.4	338.2	407.3	410.2	451.2	458.6	532.6	564.2	603.1
	l/s	14.5	17.7	20.6	21.3	25.7	25.8	28.4	28.9	33.6	35.5	38.0
Nominal Water Pressure Drop	ft.wg	9.2	21.4	22.7	22.3	23.0	22.9	22.2	22.2	23.7	23.7	21.1
	kPa	27.5	64.0	67.9	66.7	68.8	68.5	66.4	66.4	70.9	70.9	63.1
Min. Water Flow	Usgpm	141	117	138	138	163	163	188	188	211	211	252
	l/s	8.9	7.4	8.7	8.7	10.3	10.3	11.8	11.8	13.3	13.3	15.9
Max. Water Flow	Usgpm	472	389	461	461	543	543	625	625	702	702	840
	l/s	29.7	24.5	29.0	29.0	34.2	34.2	39.4	39.4	44.2	44.2	52.9
Min. Water Pressure Drop	ft.wg	3.8	4.4	4.8	4.5	4.4	4.3	4.6	4.4	4.5	4.0	4.4
	kPa	11.4	13.2	14.4	13.5	13.2	12.9	13.8	13.2	13.5	12.0	13.2
Max. Water Pressure Drop	ft.wg	33.2	38.6	42.2	38.9	38.5	37.9	39.8	38.7	39.0	35.2	38.2
	kPa	99.3	115.4	126.2	116.3	115.1	113.3	119.0	115.7	116.6	105.2	114.2
Condenser												
Total Air Flow	ft ³ /min	68,250	100,695	119,280	95,550	134,190	151,200	143,325	166,320	166,320	181,440	196,560
	m ³ /hr	115,957	171,081	202,657	162,339	227,989	256,889	243,509	282,578	282,578	308,267	333,955
Total Face Area	sq.ft	117.6	164	188.2	164	211.8	256.7	256.7	282.3	282.3	308	333.7
	sq.m	10.9	15.2	17.5	15.2	19.7	23.8	23.8	26.2	26.2	28.6	31.0
No of Fans		5	7	8	7	9	10	10	11	11	12	13
Fan Motor HP		3.0	3.0	3.0	3.0	3.0	3.0	3.0	3.0	3.0	3.0	3.0
General												
Unit Length	inches	142 1/8	187 3/8	228 3/8	187 3/8	228 3/8	272 7/8	272 7/8	286	286	317 3/8	331 1/8
	mm	3610	4760	5800	4760	5800	6930	6930	7260	7260	8060	8410
Unit Width	inches	88	88	88	88	88	88	88	88	88	88	88
	mm	2240	2240	2240	2240	2240	2240	2240	2240	2240	2240	2240
Unit Height	inches	88	88	88	88	88	98	98	98	98	98	98
	mm	2240	2240	2240	2240	2240	2490	2490	2490	2490	2490	2490
Shipping Weight	lbs	7310	8294	10754	8632	9921	11958	13247	11953	12949	14871	15050
	kg	3316	3762	4878	3915	4500	5424	6009	5422	5874	6745	6827
Operating Weight	lbs	7500	8497	10979	8861	10194	12232	13547	12253	13297	15215	15469
	kg	3402	3854	4980	4019	4624	5548	6145	5558	6032	6901	7017
Operating Charge R134a	lbs	223	271	315	326	392	397	434	441	511	542	580
	kg	101	123	143	148	178	180	197	200	232	246	263

Notes: 1. The above data are rated in accordance with AHRI Standard 550/590 with following conditions:
 Evaporator leaving fluid temperature 44°F with fluid flow rate 2.4 USgpm/ton; ambient temperature at 95°F; evaporator fouling factor 0.0001hr.ft².°F/Btu
 2. To consult nearest Dunham-Bush sales office for computer selections other than above operating conditions



PHYSICAL SPECIFICATIONS

50 Hz

Model AVX-A		260T	285T	320T	340T	365T	400T	450T	450M	490M	520T	520M
Cooling Capacity	TR	261.8	283.2	320.0	341.5	365.0	388.7	451.4	451.4	487.3	529.6	529.6
	kW	921	996	1125	1201	1284	1367	1588	1588	1714	1863	1863
Power Input	kW	280.4	305.1	335.1	356.9	379.4	401.4	464.9	464.9	503.3	556.3	556.3
Energy efficiency	kW/TR	1.071	1.077	1.047	1.045	1.039	1.033	1.030	1.030	1.033	1.050	1.050
COP	kW _e /kW _i	3.284	3.265	3.359	3.365	3.384	3.406	3.415	3.415	3.405	3.348	3.348
Compressor												
Quantity		2	2	2	2	2	2	2	2	2	2	2
RPM		2950	2950	2950	2950	2950	2950	2950	2950	2950	2950	2950
Min. % Unit Capacity Reduction		12.5%	12.5%	12.5%	12.5%	12.5%	12.5%	12.5%	12.5%	12.5%	12.5%	12.5%
No. Of Refrigerant Circuit		2	2	2	2	2	2	2	2	2	2	2
Evaporator												
Model (Qty)		JCRT (1)	Q1RT (1)	S1RT (1)	S2RT (1)	S3RT (1)	2FR (2)	EBR (2)	EBR (2)	JCR(2)	JCR (2)	JCR (2)
Water Connector	inches	8	8	8	8	8	8	10	10	10	10	10
	mm	203.2	203.2	203.2	203.2	203.2	203.2	254	254	254	254	254
Nominal Water Flow	Usgpm	628.3	679.7	768.0	819.6	876.0	932.9	1083.4	1083.4	1169.5	1271.0	1271.0
	l/s	39.6	42.8	48.4	51.6	55.2	58.8	68.3	68.3	73.8	80.1	80.1
Nominal Water Pressure Drop	ft.wg	22.7	23.0	21.7	19.5	21.9	27.8	31.3	31.3	21.8	26.0	26.0
	kPa	67.9	68.8	64.9	58.3	65.5	83.1	93.6	93.6	65.2	77.7	77.7
Min. Water Flow	Usgpm	252	280	329	375	393	375	421	421	504.0	504	504
	l/s	15.9	17.6	20.7	23.6	24.8	23.6	26.5	26.5	31.8	31.8	31.8
Max. Water Flow	Usgpm	840	932	1096	1250	1312	1250	1404	1404	1681.0	1681	1681
	l/s	52.9	58.7	69.0	78.8	82.7	78.8	88.5	88.5	106.1	105.9	105.9
Min. Water Pressure Drop	ft.wg	4.4	4.7	4.7	4.8	5.2	5.4	5.7	5.7	4.9	4.9	4.9
	kPa	13.2	14.1	14.1	14.4	15.5	16.1	17.0	17.0	14.6	14.7	14.7
Max. Water Pressure Drop	ft.wg	38.2	40.7	41.1	41.6	45.2	47.2	49.9	49.9	43.0	43.0	43.0
	kPa	114.2	121.7	122.9	124.4	135.1	141.1	149.2	149.2	128.5	128.6	128.6
Condenser												
Total Air Flow	ft ³ /min	171,990	200,655	200,655	229,320	229,320	257,985	280,665	332,640	362880	389,340	393,120
	m ³ /hr	292,211	340,913	340,913	389,615	389,615	438,317	476,850	565,155	616533	661,489	667,911
Total Face Area	sq.ft	308	359.3	359.3	410.7	410.7	462	577.5	564.6	616	577.5	667.4
	sq.m	28.6	33.4	33.4	38.2	38.2	42.9	53.7	52.5	57.23	53.7	62.0
No of Fans		12	14	14	16	16	18	18	22	24	18	26
Fan Motor HP		3.0	3.0	3.0	3.0	3.0	3.0	3.0	3.0	3.0	7.5	3.0
General												
Unit Length	inches	317 3/8	362 5/8	362 5/8	407 7/8	407 7/8	453 1/8	453 1/8	544 7/8	590	453 1/8	635 7/8
	mm	8060	9210	9210	10360	10360	11510	11510	13840	15000	11510	16150
Unit Width	inches	88	88	88	88	88	88	88	88	88	88	88
	mm	2240	2240	2240	2240	2240	2240	2240	2240	2240	2240	2240
Unit Height	inches	98	98	98	98	98	98	121	98	98	121	98
	mm	2490	2490	2490	2490	2490	2490	3070	2490	2490	3070	2490
Shipping Weight	lbs	15523	16790	17535	19046	19427	21310	24528	27441	29811	26983	31128
	kg	7041	7616	7954	8639	8812	9666	11126	12447	13522	12239	14119
Operating Weight	lbs	15938	17253	18082	19650	20058	21919	25225	28138	30649	27821	31965
	kg	7229	7826	8202	8913	9098	9942	11442	12763	13902	12619	14499
Operating Charge R134a	lbs	604	655	741	791	844	899	1,045	1,045	1133	1,226	1,226
	kg	274	297	336	359	383	408	474	474	515	556	556

Notes: 1. The above data are rated in accordance with AHRI Standard 550/590 with following conditions:
 Evaporator leaving fluid temperature 44°F with fluid flow rate 2.4 USgpm/ton; ambient temperature at 95°F; evaporator fouling factor 0.0001hr.ft².°F/Btu
 2. To consult nearest Dunham-Bush sales office for computer selections other than above operating conditions



PHYSICAL SPECIFICATIONS

60 Hz

Model AVX-A		115S	140S	170S	200S	225S	225T	250T	265S	280T
Cooling Capacity	TR	115.4	140.2	170.0	201.7	226.0	225.5	250.5	265.2	280.3
	kW	406	493	598	709	795	793	881	933	986
Power Input	kW	125.7	151.1	187.8	212.8	238.5	251.6	275.2	277.7	297.7
Energy Efficiency	kW/TR	1.089	1.078	1.105	1.055	1.055	1.116	1.099	1.047	1.062
COP	kW/kWi	3.229	3.263	3.184	3.334	3.333	3.152	3.202	3.359	3.311
Compressor										
Quantity		1	1	1	1	1	2	2	1	2
RPM		3550	3550	3550	3550	3550	3550	3550	3550	3550
Min. % Unit Capacity Reduction		25%	25%	25%	25%	25%	12.5%	12.5%	25%	12.5%
No. Of Refrigerant Circuit		1	1	1	1	1	2	2	1	2
Evaporator										
Model (Qty)		1CR (1)	1DR (1)	2ER (1)	2FR (1)	EBR (1)	EBRT (1)	JCRT (1)	JCR (1)	JCRT (1)
Water Connector	inches	5	5	6	6	6	6	8	8	8
	mm	127	127	152.4	152.4	152.4	152.4	203.2	203.2	203.2
Nominal Water Flow	Us gpm	277.0	336.5	408.0	484.1	542.4	541.2	601.2	636.5	672.7
	l/s	17.4	21.2	25.7	30.5	34.2	34.1	37.9	40.1	42.4
Nominal Water Pressure Drop	ft.wg	21.4	22.3	23.0	23.0	24.0	22.6	20.4	22.9	25.0
	kPa	64.0	66.7	68.8	68.8	71.8	67.6	61.1	68.5	74.8
Min. Water Flow	Us gpm	117.0	138.0	163.0	188.0	211.0	211.0	252.0	252.0	252.0
	l/s	7.4	8.7	10.3	11.8	13.3	13.3	15.9	15.9	15.9
Max. Water Flow	Us gpm	389.0	461.0	543.0	625.0	702.0	702.0	840.0	840.0	840.0
	l/s	24.5	29.0	34.2	39.4	44.2	44.2	52.9	52.9	52.9
Min. Water Pressure Drop	ft.wg	4.4	4.5	6.1	4.5	4.5	4.5	4.4	4.4	4.4
	kPa	13.2	13.5	18.2	13.5	13.5	13.5	13.2	13.2	13.2
Max. Water Pressure Drop	ft.wg	38.6	39.3	53.0	39.0	39.0	39.0	38.4	38.4	38.4
	kPa	115.4	117.5	158.5	116.6	116.6	116.6	114.8	114.8	114.8
Condenser										
Total Air Flow	ft ³ /min	104,370	95,550	134,190	166,320	166,320	181,440	211,680	196,560	200,655
	m ³ /hr	177,325	162,339	227,989	282,578	282,578	308,267	359,644	333,955	340,913
Total Face Area	sq.ft	164.69	164.69	211.75	282.33	282.33	308.00	359.33	333.67	359.33
	sq.m	15.30	15.30	19.67	26.23	26.23	28.61	33.38	31.00	33.38
No. of Fans		7	7	9	11	11	12	14	13	14
Fan Motor HP		3.0	3.0	3.0	3.0	3.0	3.0	3.0	3.0	3.0
General										
Unit Length	inches	187 3/8	187 3/8	228 3/8	286	286	317 3/8	362 5/8	331 1/8	362 5/8
	mm	4760	4760	5800	7260	7260	8060	9210	8410	9210
Unit Width	inches	88	88	88	88	88	88	88	88	88
	mm	2240	2240	2240	2240	2240	2240	2240	2240	2240
Unit Height	inches	88	88	88	98	98	98	98	98	98
	mm	2240	2240	2240	2490	2490	2490	2490	2490	2490
Shipping Weight	lbs	8266	8562	9720	11704	12230	14813	16460	14883	16524
	kg	3749	3883	4409	5309	5548	6719	7466	6751	7495
Operating Weight	lbs	8468	8764	9994	12004	12579	15162	16879	15301	16943
	kg	3841	3975	4533	5445	5706	6877	7656	6941	7685
Operating Charge R134a	lbs	265	309	375	463	518	518	573	606	639
	kg	120	140	170	210	235	235	260	275	290

Notes: 1. The above data are rated in accordance with AHRI Standard 550/590 with following conditions:
 Evaporator leaving fluid temperature 44°F with fluid flow rate 2.4 USgpm/ton; ambient temperature at 95°F; evaporator fouling factor 0.0001hr.ft².°F/Btu
 2. To consult nearest Dunham-Bush sales office for computer selections other than above operating conditions



PHYSICAL SPECIFICATIONS

60 Hz

Model AVX-A		300S	300T	330T	350T	380T	400T	440M	470M	540M
Cooling Capacity	TR	300.1	306.2	333.0	358.0	381.8	410.2	444.1	470.8	548.4
	kW	1055	1077	1171	1259	1343	1443	1562	1656	1929
Power Input	kW	315.3	333.5	368.1	391.6	402.5	438.5	459.4	485.9	554.8
Energy Efficiency	kW/TR	1.051	1.089	1.105	1.094	1.054	1.069	1.034	1.032	1.012
COP	kW _e /kW _i	3.347	3.229	3.182	3.216	3.336	3.290	3.400	3.408	3.476
Compressor										
Quantity		1	2	2	2	2	2	2	2	2
RPM		3550	3550	3550	3550	3550	3550	3550	3550	3550
Min. % Unit Capacity Reduction		25%	12.5%	12.5%	12.5%	12.5%	12.5%	12.5%	12.5%	12.5%
No. Of Refrigerant Circuit		1	2	2	2	2	2	2	2	2
Evaporator										
Model (Qty)		Q1R (1)	S2RT (1)	S2RT (1)	2FR (2)	2FR (2)	2FR (2)	EDR(2)	EBR (2)	JCR (2)
Water Connector	inches	8	8	8	8	8	8	10	10	10
	mm	203.2	203.2	203.2	203.2	203.2	203.2	254	254	254
Nominal Water Flow	USgpm	720.2	734.9	799.2	859.2	916.3	984.5	1069.7	1129.9	1316.1
	l/s	45.4	46.3	50.3	54.1	57.7	62.0	67.5	71.2	82.9
Nominal Water Pressure Drop	ft.wg	25.2	19.8	23.0	24.2	27.2	30.5	28.0	33.2	27.8
	kPa	75.3	59.1	68.8	72.4	81.3	91.2	83.7	99.3	83.1
Min. Water Flow	USgpm	280.0	329.0	329.0	375.0	375.0	375.0	427.4	421.0	504.0
	l/s	17.6	20.7	20.7	23.6	23.6	23.6	27.0	26.5	31.8
Max. Water Flow	USgpm	932.0	1096.0	1096.0	1250.0	1250.0	1250.0	1396.9	1404.0	1681.0
	l/s	58.7	69.0	69.0	78.8	78.8	78.8	88.1	88.5	105.9
Min. Water Pressure Drop	ft.wg	4.7	4.8	4.8	5.4	5.4	5.4	5.6	5.7	4.9
	kPa	14.1	14.4	14.4	16.1	16.1	16.1	16.7	17.0	14.7
Max. Water Pressure Drop	ft.wg	40.6	41.5	41.5	47.2	47.2	47.2	44.8	49.6	43.1
	kPa	121.4	124.1	124.1	141.1	141.1	141.1	134.0	148.3	128.9
Condenser										
Total Air Flow	ft ³ /min	226,800	241,920	229,320	272,160	257,985	257,985	325,710	332,640	371,280
	m ³ /hr	385,333	411,022	389,615	462,400	438,317	438,317	553,381	565,155	630,805
Total Face Area	sq.ft	385.00	410.67	410.67	462.00	462.00	462.00	546.67	546.67	667.4
	sq.m	35.77	38.15	38.15	42.92	42.92	42.92	50.79	50.79	62.00
No. of Fans		15	16	16	18	18	18	22	22	26
Fan Motor HP		3.0	3.0	3.0	3.0	3.0	3.0	3.0	3.0	3.0
General										
Unit Length	inches	376 3/4	407 7/8	407 7/8	453 1/8	453 1/8	453 1/8	545	545	634 5/8
	mm	9570	10360	10360	11510	11510	11510	13840	13840	16120
Unit Width	inches	88	88	88	88	88	88	88	88	88
	mm	2240	2240	2240	2240	2240	2240	2240	2240	2240
Unit Height	inches	98	98	98	98	98	98	98	98	98
	mm	2490	2490	2490	2490	2490	2490	2490	2490	2490
Shipping Weight	lbs	16501	18765	18645	20805	20546	20812	25705	26004	30793
	kg	7485	8512	8457	9437	9319	9440	11660	11795	13967
Operating Weight	lbs	16969	19184	19253	21413	21154	21421	26402	26700	31630
	kg	7697	8702	8733	9713	9595	9716	11976	12111	14347
Operating Charge R134a	lbs	683	683	750	794	860	904	990	1,058	1,168
	kg	310	310	340	360	390	410	450	480	530

Notes: 1. The above data are rated in accordance with AHRI Standard 550/590 with following conditions:
 Evaporator leaving fluid temperature 44°F with fluid flow rate 2.4 USgpm/ton; ambient temperature at 95°F; evaporator fouling factor 0.0001hr.ft².°F/Btu
 2. To consult nearest Dunham-Bush sales office for computer selections other than above operating conditions



ELECTRICAL DATA

Model AVX-A	Cond. Fan Motor Data			Compressor Data			Unit Electrical Data									
	Qty	HP	FLA	Starter Type	Qty	LRA	Operation At 95°F Ambient Temperature					Operation At 115°F Ambient Temperature				
							Compr RLA	Unit RLA	MCA	MFS	Max Inrush	Compr RLA	Unit RLA	MCA	MFS	Max Inrush
POWER SUPPLY: 380V-3ph-50Hz																
95S	5	3	6.3	Part Winding	1	999	166	198	239	400	679	199	230	280	450	679
115S	7	3	6.3	Part Winding	1	999	197	241	290	450	679	257	301	365	600	679
135T	8	3	6.3	Part Winding	2	976	136	322	356	450	814	155	360	399	500	814
140S	7	3	6.3	Part Winding	1	1295	241	285	345	500	881	320	364	444	700	881
170S	9	3	6.3	Part Winding	1	1391	280	337	407	600	946	357	414	503	800	946
170T	10	3	6.3	Part Winding	2	976	153	368	406	500	851	185	434	480	600	851
185T	10	3	6.3	Part Winding	2	999	164	391	432	500	907	196	455	504	600	907
200S	11	3	6.3	Part Winding	1	1878	300	369	444	700	1197	369	439	531	800	1197
220S	11	3	6.3	Star-Delta	1	2481	362	431	522	800	1654	453	522	635	1000	1654
235T	12	3	6.3	Part Winding	2	999	195	465	514	700	971	254	583	646	800	971
250S	13	3	6.3	Star-Delta	1	2887	412	493	596	1000	1924	509	591	719	1200	1924
260T	5	3	6.3	Part Winding	1	999	202	515	574	800	1170	257	652	732	1000	1170
	7	3	6.3	Part Winding	1	1295	237					320				
285T	14	3	6.3	Part Winding	2	1295	237	562	621	800	1236	311	709	787	1000	1236
	6	3	6.3	Part Winding	1	1295	237	615	687	800	1304	320	772	863	1200	1304
8	3	6.3	Part Winding	1	1391	289	364									
340T	16	3	6.3	Part Winding	2	1391	279	659	728	1000	1353	357	814	904	1200	1353
365T	7	3	6.3	Part Winding	1	1391	278	698	777	1000	1605	364	857	954	1200	1605
	9	3	6.3	Part Winding	1	1878	319					392				
400T	18	3	6.3	Part Winding	2	1878	320	753	833	1000	1653	399	911	1011	1200	1653
450M	11	3	6.3	Star-Delta	1	2481	362	431	522	800	1654	453	522	635	1000	1654
	11	3	6.3	Star-Delta	1	2481	362	431	522	800	1654	453	522	635	1000	1654
450M*	22	3	6.3	Star-Delta	2	2481	362	863	953	1200	2176	453	1044	1157	1600	2176
450T	18	3	6.3	Star-Delta	2	2481	377	867	961	1200	2186	475	1063	1182	1600	2186
490M	13	3	5.3	Star-Delta	1	2481	404	473	574	800	952	509	578	705	1200	952
	11	3	5.3	Star-Delta	1	2122	370	428	521	800	819	505	563	690	1000	819
490M	24	3	5.3	Star-Delta	1	2481	404	901	1002	1200	1380	509	1141	1268	1600	1515
				Star-Delta	1	2122	370					505				
520M	13	3	6.3	Star-Delta	1	2887	412	493	596	1000	1924	509	591	719	1200	1924
	13	3	6.3	Star-Delta	1	2887	412	493	596	1000	1924	509	591	719	1200	1924
520M*	26	3	6.3	Star-Delta	2	2887	412	987	1090	1200	2515	509	1183	1310	1600	2515
520T	18	7.5	12	Star-Delta	2	2887	422	1060	1166	1600	2553	521	1258	1388	1600	2553
POWER SUPPLY: 400V-3ph-50Hz																
95S	5	3	6	Part Winding	1	949	158	188	228	350	566	189	219	266	400	566
115S	7	3	6	Part Winding	1	949	187	229	276	450	566	244	286	347	500	566
135T	8	3	6	Part Winding	2	927	129	306	338	450	619	147	342	379	500	619
140S	7	3	6	Part Winding	1	1230	229	271	328	500	566	304	346	422	700	566
170S	9	3	6	Part Winding	1	1321	266	320	387	600	694	339	393	478	800	694
170T	10	3	6	Part Winding	2	927	145	350	386	500	654	176	412	456	600	654
185T	10	3	6	Part Winding	2	949	156	372	411	500	772	186	432	479	600	772
200S	11	3	6	Part Winding	1	1784	285	351	422	700	920	351	417	505	800	920
220S	11	3	6	Star-Delta	1	2357	344	410	496	800	1076	430	496	604	1000	1076
235T	12	3	6	Part Winding	2	949	185	442	488	600	843	241	554	614	800	843
250S	13	3	6	Star-Delta	1	2743	391	469	567	800	1252	484	562	683	1100	1252
260T	5	3	6	Part Winding	1	949	192	489	545	700	912	244	620	696	1000	912
	7	3	6	Part Winding	1	1230	225					304				
285T	14	3	6	Part Winding	2	1230	225	534	590	800	903	295	674	748	1000	903
	6	3	6	Part Winding	1	1230	225	584	653	800	1034	304	734	821	1100	1034
8	3	6	Part Winding	1	1321	275	346									
340T	16	3	6	Part Winding	2	1321	265	626	692	800	1081	339	774	859	1100	1081
365T	7	3	6	Part Winding	1	1321	264	663	739	1000	1308	346	814	907	1250	1308
	9	3	6	Part Winding	1	1784	303					372				
400T	18	3	6	Part Winding	2	1784	304	716	792	1000	1353	379	866	961	1250	1353
450M	11	3	6	Star-Delta	1	2357	344	410	496	800	1076	430	496	604	1000	1076
	11	3	6	Star-Delta	1	2357	344	410	496	800	1076	430	496	604	1000	1076
450M*	22	3	6	Star-Delta	2	2357	344	820	906	1200	1572	430	992	1000	1500	1572
450T	18	3	6	Star-Delta	2	2357	358	824	914	1200	1581	451	1010	1123	1500	1581
490M	13	3	5.3	Star-Delta	1	2357	384	453	549	800	903	483	552	673	1000	903
	11	3	5.3	Star-Delta	1	2016	352	410	498	800	781	480	538	658	1000	781
490M	24	3	5.3	Star-Delta	1	2357	384	863	959	1200	1313	483	1090	1211	1600	1441
				Star-Delta	1	2016	352					480				
520M	13	3	6	Star-Delta	1	2743	391	469	567	800	1252	484	562	683	1100	1252
	13	3	6	Star-Delta	1	2743	391	469	567	800	1252	484	562	683	1100	1252
520M*	26	3	6	Star-Delta	2	2743	391	938	1036	1200	1814	484	1124	1245	1600	1814
520T	18	7.5	11.5	Star-Delta	2	2743	401	1009	1109	1200	1851	495	1197	1321	1600	1851

* Modular unit with single power entry.

Note: RLA - Running Load Amps MCA - Minimum Circuit Ampacity MFS - Maximum Fuse Size LRA - Lock Rotor Amp



ELECTRICAL DATA

Model AVX-A	Condenser Fan Motor Data			Compressor Data			Unit Electrical Data									
	Qty	HP	FLA	Starter Type	Qty	LRA	Operation At 95°F Ambient Temperature					Operation At 115°F Ambient Temperature				
							Compr RLA	Unit RLA	MCA	MFS	Max Inrush	Compr RLA	Unit RLA	MCA	MFS	Max Inrush
POWER SUPPLY: 380Vac-3Ph-60Hz																
115S	7	3	5.4	Part Winding	1	1209	196	234	283	450	669	234	271	330	500	669
140S	7	3	5.4	Part Winding	1	1209	235	273	331	500	669	305	343	419	700	669
170S	9	3	5.4	Part Winding	1	1567	291	339	412	700	809	379	427	522	800	809
200S	11	3	5.4	Part Winding	1	1683	328	387	469	700	883	414	473	577	1000	883
225S	11	3	5.4	Part Winding	1	2272	374	433	527	900	1171	461	521	636	1000	1171
225T	12	3	5.4	Part Winding	2	1209	200	464	514	700	940	238	542	601	800	940
250T	14	3	5.4	Part Winding	1	1209	186	496	554	700	1290	218	566	634	800	1322
				Part Winding	1	1567	234					272				
265S	13	3	5.4	Star-Delta	1	3002	436	506	615	1000	1463	540	610	745	1200	1463
280T	14	3	5.4	Part Winding	2	1209	231	538	596	800	1007	300	676	751	1000	1007
300S	15	3	5.4	Star-Delta	1	3493	499	580	704	1200	1595	613	694	847	1200	1595
300T	16	3	5.4	Part Winding	1	1567	239	607	678	800	1427	278	692	774	1000	1466
				Part Winding	1	1683	282					328				
330T	16	3	5.4	Part Winding	2	1567	288	663	735	1000	1227	375	837	931	1200	1227
				Part Winding	1	1683	288					335				
350T	18	3	5.4	Part Winding	1	2272	335	720	804	1000	1785	387	819	916	1200	1832
				Part Winding	1	1683	288					433				
380T	18	3	5.4	Part Winding	1	1567	288	725	811	1000	1303	376	907	1015	1200	1303
				Part Winding	1	1683	340					433				
400T	18	3	5.4	Part Winding	2	1683	351	799	887	1200	1382	450	998	1110	1200	1382
440M	11	3	5.4	Part Winding	1	1209	334	393	477	800	470	440	499	609	1000	470
	11	3	5.4	Part Winding	1	1683	369	428	521	800	731	464	523	639	1000	731
440M*	22	3	5.4	Part Winding	1	1209	334	822	914	1200	1125	440	1023	1139	1600	1231
				Part Winding	1	1683	369					464				
470M	11	3	5.4	Part Winding	1	2272	387	447	544	800	1171	461	540	660	1000	1171
	11	3	5.4	Part Winding	1	2272	387	447	544	800	1171	481	540	660	1000	1171
470M*	22	3	5.4	Part Winding	2	2272	387	890	990	1200	1711	481	890	1200	1600	1711
540M	13	3	5.4	Star-Delta	1	2481	442	512	623	1000	1654	550	620	758	1200	1654
	13	3	5.4	Star-Delta	1	2481	442	512	623	1000	1654	550	620	758	1200	1654
540M*	26	3	5.4	Star-Delta	2	2481	442	1024	1135	1200	2166	550	1240	1378	1600	2274
POWER SUPPLY: 460Vac-3Ph-60Hz																
115S	7	3	4.4	Part Winding	1	999	162	193	233	350	553	193	224	272	450	553
140S	7	3	4.4	Part Winding	1	999	194	225	273	450	553	252	283	346	600	553
170S	9	3	4.4	Part Winding	1	1295	240	280	340	500	669	313	353	431	700	669
200S	11	3	4.4	Part Winding	1	1391	271	319	387	600	730	342	390	476	800	730
225S	11	3	4.4	Part Winding	1	1878	309	357	435	700	968	381	429	525	800	968
225T	12	3	4.4	Part Winding	2	999	165	383	424	500	776	197	447	496	600	776
250T	14	3	4.4	Part Winding	1	999	154	409	457	600	1066	180	467	523	700	1092
				Part Winding	1	1295	193					225				
265S	13	3	4.4	Star-Delta	1	2481	360	417	507	800	1209	446	503	615	1000	1209
280T	14	3	4.4	Part Winding	2	999	191	444	491	600	832	248	558	620	800	832
300S	15	3	4.4	Star-Delta	1	2887	412	478	581	900	1318	506	572	699	1200	1318
300T	16	3	4.4	Part Winding	1	1295	198	501	560	700	1179	230	571	639	800	1211
				Part Winding	1	1391	233					271				
330T	16	3	4.4	Part Winding	2	1295	238	546	606	800	1014	310	690	768	1000	1014
				Part Winding	1	1391	238					277				
350T	18	3	4.4	Part Winding	1	1878	277	594	663	800	1475	320	676	756	1000	1514
				Part Winding	1	1391	281					358				
380T	18	3	4.4	Part Winding	1	1295	238	598	668	800	1076	311	748	838	1000	1076
				Part Winding	2	1391	290					659				
440M	11	3	4.4	Part Winding	1	999	276	324	393	600	388	363	411	502	800	388
	11	3	4.4	Part Winding	1	1391	305	353	430	700	604	384	432	528	800	604
440M*	22	3	4.4	Part Winding	1	999	276	678	754	1000	929	363	844	940	1200	1016
				Part Winding	1	1391	305					384				
470M	11	3	4.4	Part Winding	1	1878	320	368	448	700	968	397	445	545	800	968
	11	3	4.4	Part Winding	1	1878	320	368	448	700	968	397	445	545	800	968
470M*	22	3	4.4	Part Winding	2	1878	320	890	817	1000	1413	397	890	990	1200	1413
540M	13	3	4.4	Star-Delta	1	2481	365	422	513	800	1985	454	511	625	1000	1985
	13	3	4.4	Star-Delta	1	2481	365	422	513	800	1985	454	511	625	1000	1985
540M*	26	3	4.4	Star-Delta	2	2481	365	844	936	1200	2407	454	1022	1136	1200	2496

* Modular unit with single power entry.

Note: RLA - Running Load Amps MCA - Minimum Circuit Ampacity MFS - Maximum Fuse Size LRA - Lock Rotor Amp

SOUND PRESSURE DATA

50Hz

Model AVX-A	Octave Band (Hz)								Total dB (A)
	63	125	250	500	1K	2K	4K	8K	
95S	44	52	56	57	59	50	42	35	63
115S	45	53	57	58	60	50	42	36	64
135T	46	53	58	58	60	53	45	38	64
140S	45	53	57	58	60	51	43	37	64
170S	46	54	58	58	60	51	43	37	64
170T	46	54	59	59	60	53	45	39	65
185T	46	54	58	59	62	52	44	38	65
200S	47	55	58	59	60	52	44	38	65
220S	47	55	58	59	60	51	43	37	65
235T	47	55	59	60	62	52	44	38	66
250S	47	55	59	60	60	51	44	38	65
260T	47	55	59	60	62	53	45	39	66
285T	48	55	59	60	62	54	46	39	66
320T	48	55	60	60	62	53	45	39	66
340T	48	56	60	60	62	53	45	39	66
365T	48	56	60	61	62	54	46	40	67
400T	48	56	60	61	62	54	46	40	67
450M	49	57	60	62	62	53	46	40	67
450T	48	56	60	61	62	53	45	39	67
490M	49	57	61	62	62	53	46	40	67
520M	50	57	61	62	62	53	46	40	67
520T	44	51	57	61	64	63	63	54	69

Notes: 1. Unit Sound Pressure Level (Lp) @ 33 ft [10m] (free field), ± 2 dB(A) tolerance.
 2. Further unit noise reduction 2dB(A) with compressor acoustic jacket (option).

60 Hz

Model AVX-A	Octave Band (Hz)								Total dB (A)
	63	125	250	500	1K	2K	4K	8K	
115S	57	53	56	57	63	52	43	37	66
140S	57	53	56	57	63	52	43	37	66
170S	58	54	57	57	62	54	45	38	66
200S	58	55	57	58	62	53	45	38	66
225S	58	55	57	58	62	54	45	39	66
225T	59	55	58	59	65	54	46	39	68
250T	59	56	58	59	65	56	47	40	68
265S	59	55	57	59	62	52	44	38	66
280T	59	56	58	59	65	54	46	39	68
300S	59	56	57	59	62	52	44	38	66
300T	59	56	57	59	62	52	44	38	66
330T	60	56	59	59	65	56	47	41	68
350T	60	56	59	60	64	56	47	41	68
380T	60	56	59	59	65	57	48	41	68
400T	60	56	59	59	65	55	47	40	68
440M	61	57	59	60	64	56	47	41	68
470M	61	57	59	61	64	56	48	41	68
540M	61	58	59	61	64	54	46	40	68

Notes: 1. Unit Sound Pressure Level (Lp) @ 33 ft [10m] (free field), ± 2 dB(A) tolerance.
 2. Further unit noise reduction 2dB(A) with compressor acoustic jacket (option).

DIMENSIONAL DATA

50Hz: AVX-A 95S

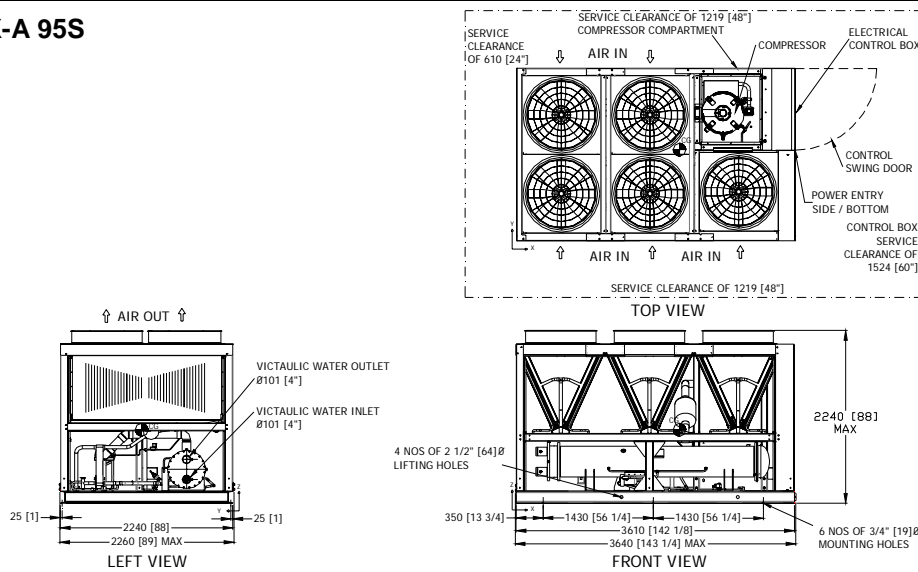

50/60Hz: AVX-A 115S, 140S

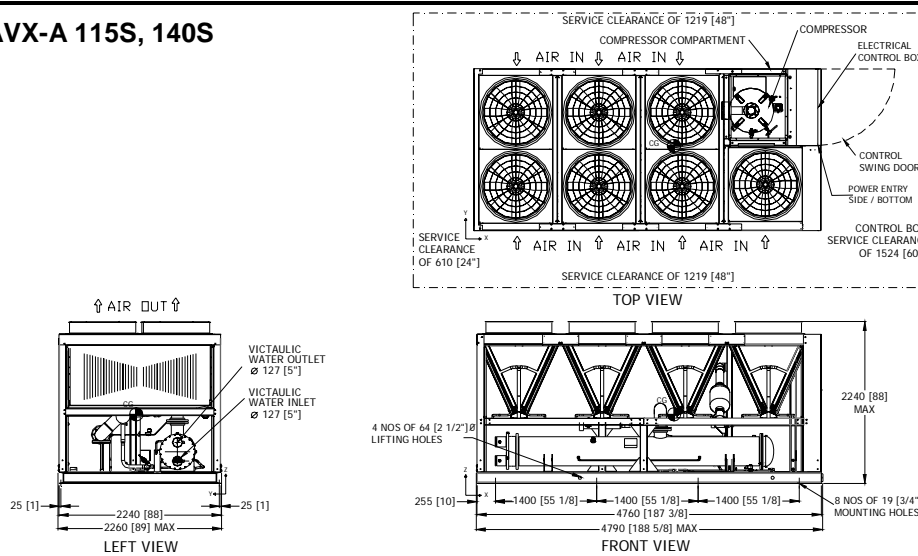

50Hz: AVX-A 135T

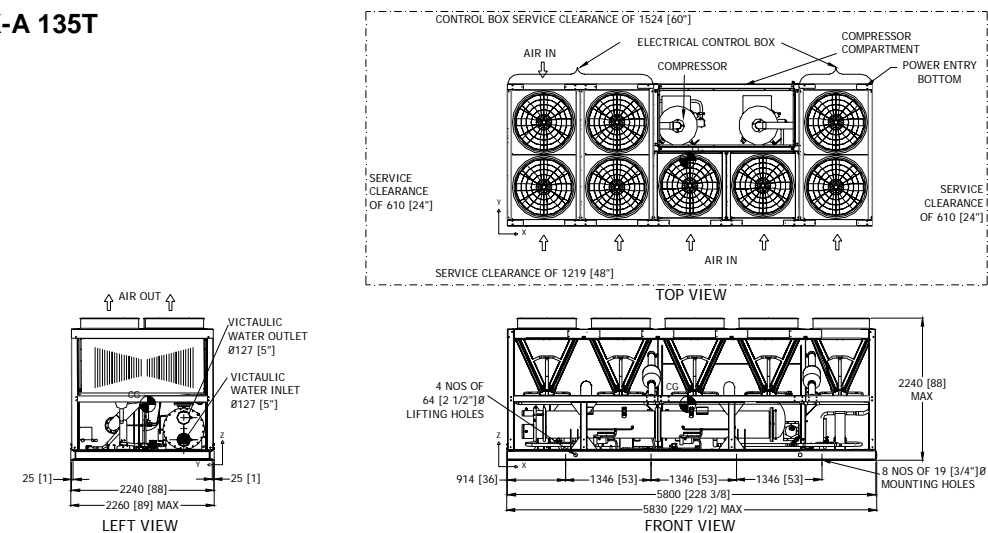

Note: All dimensions are in mm[inches].

DIMENSIONAL DATA

50/60Hz: AVX-A 170S

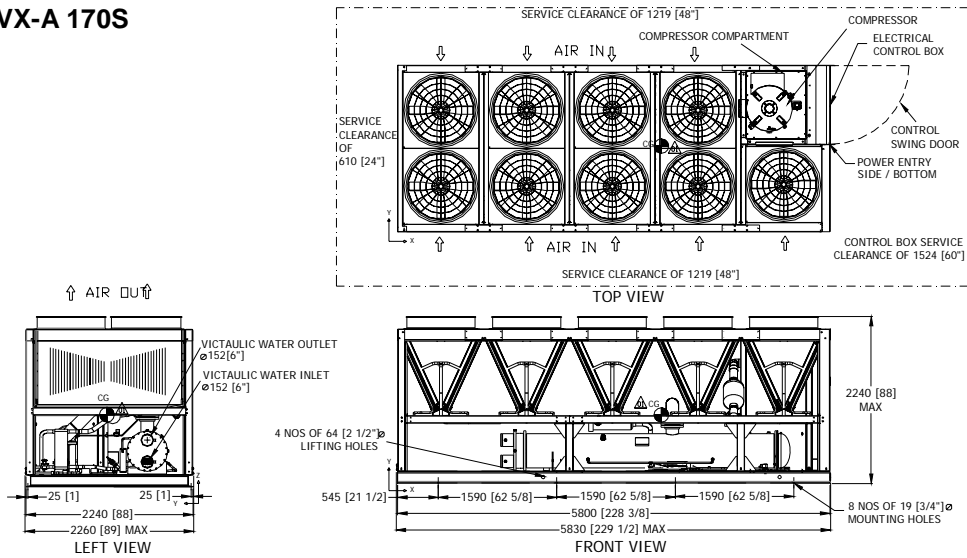

50Hz: AVX-A 170T

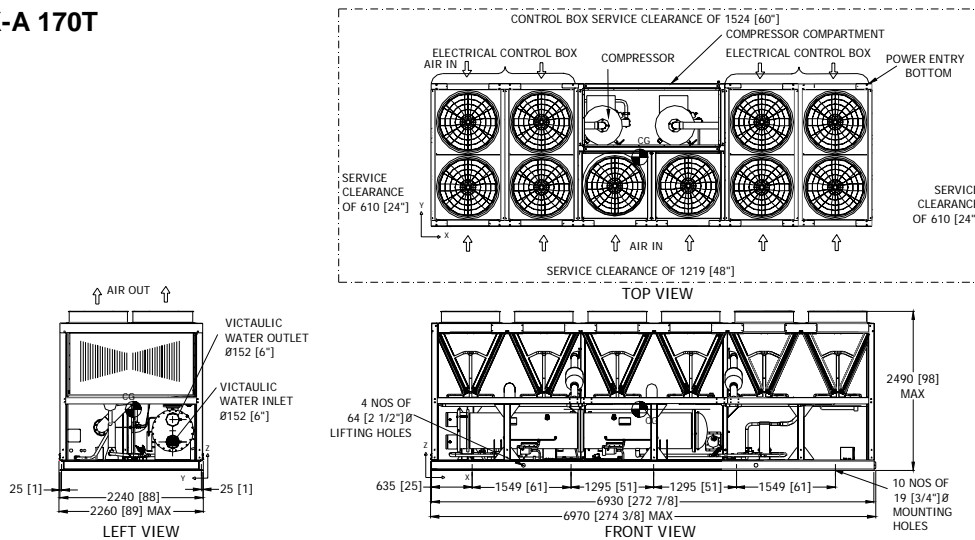

50Hz: AVX-A 185T

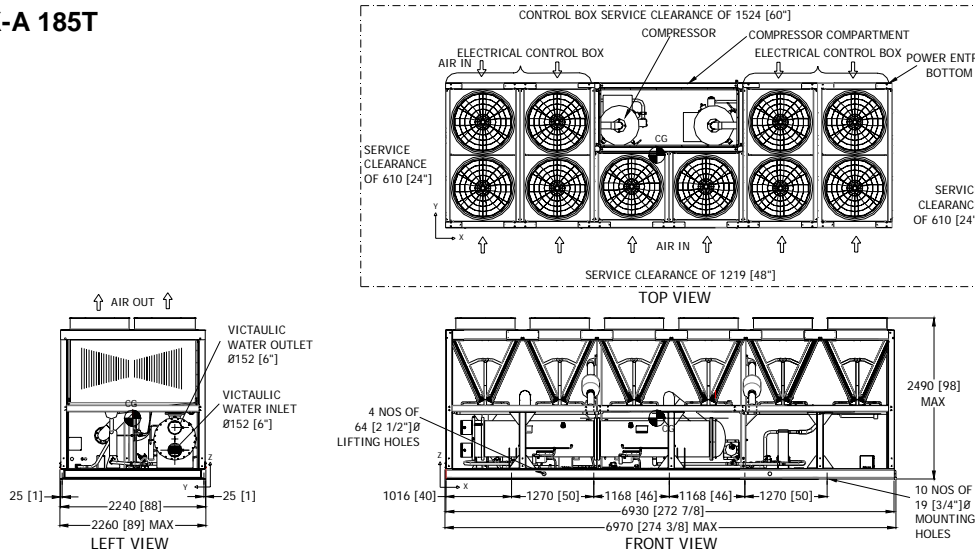

Note: All dimensions are in mm[inches].

DIMENSIONAL DATA

50Hz: AVX-A 200S, 220S
60Hz: AVX-A 200S, 225S

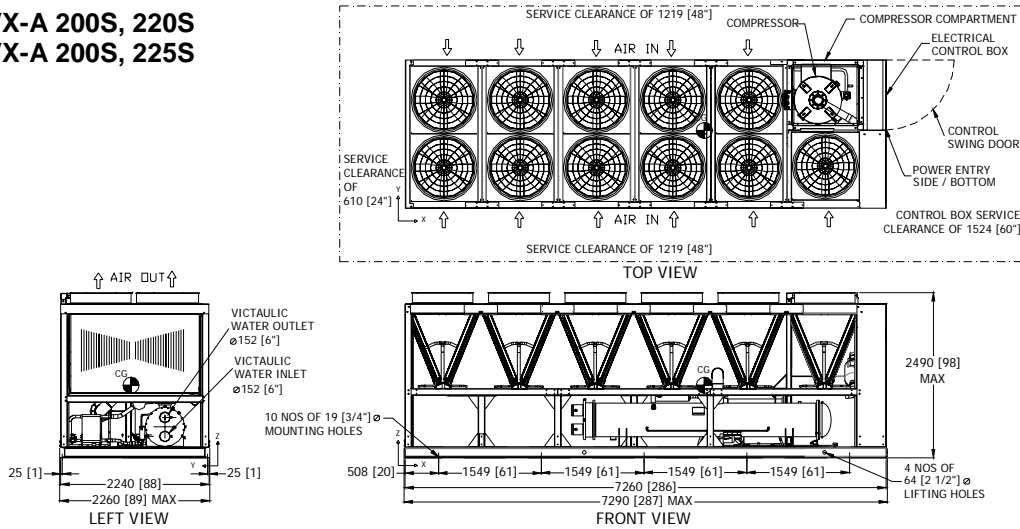

50Hz: AVX-A 235T, 260T
60Hz: AVX-A 225T

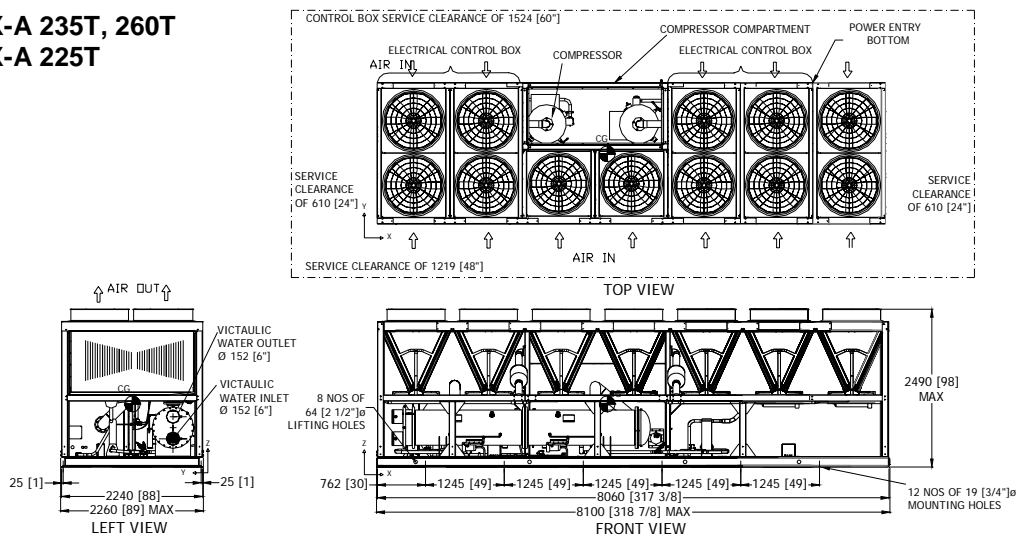

50Hz: AVX-A 250S
60Hz: AVX-A 265S

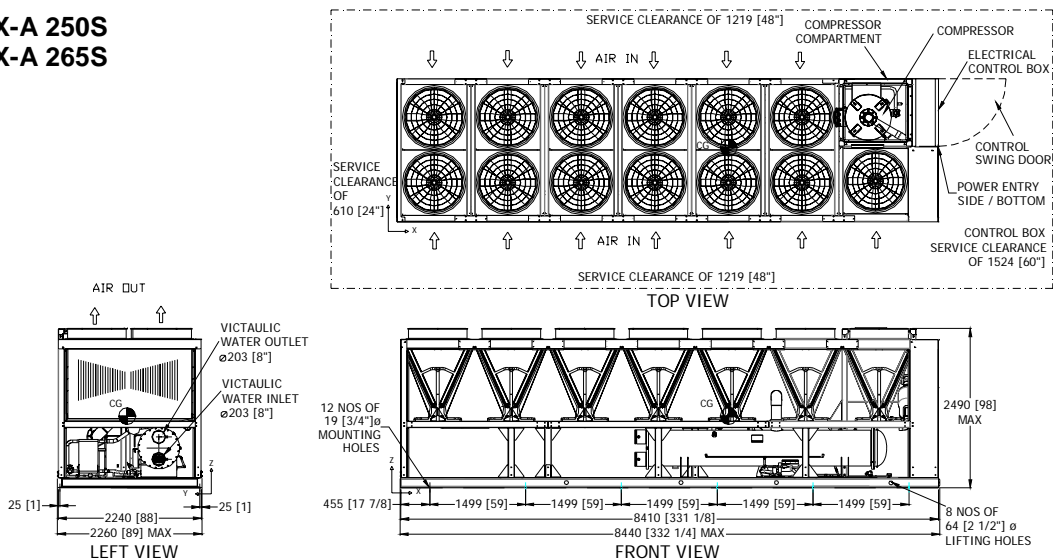

Note: All dimensions are in mm[inches].

DIMENSIONAL DATA

60Hz: AVX-A 250T

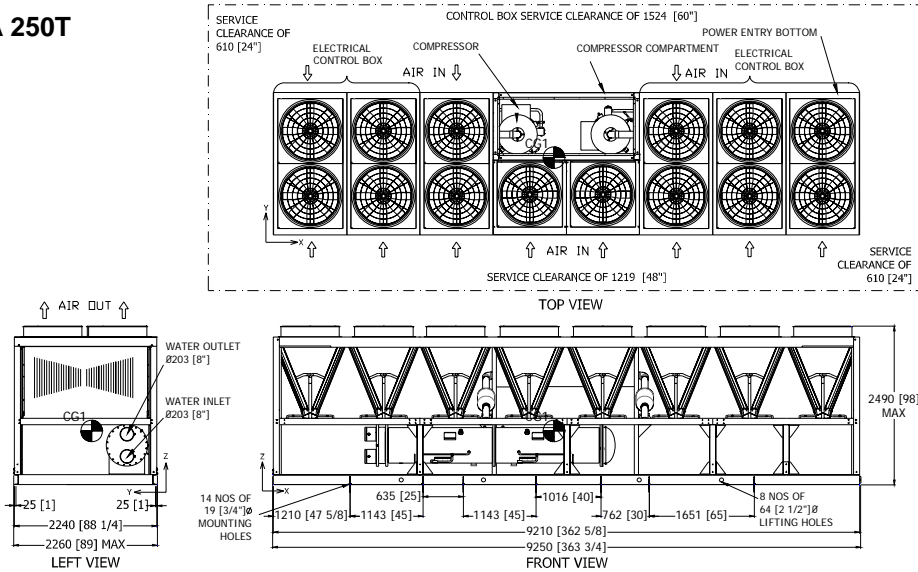

50Hz: AVX-A 285T, 320T 60Hz: AVX-A 280T

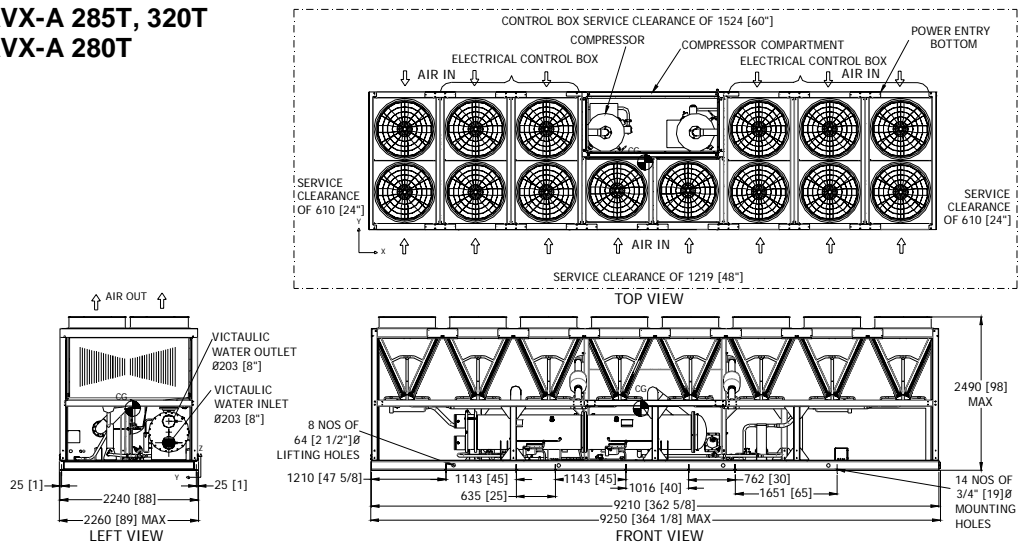

60Hz: AVX-A 300S

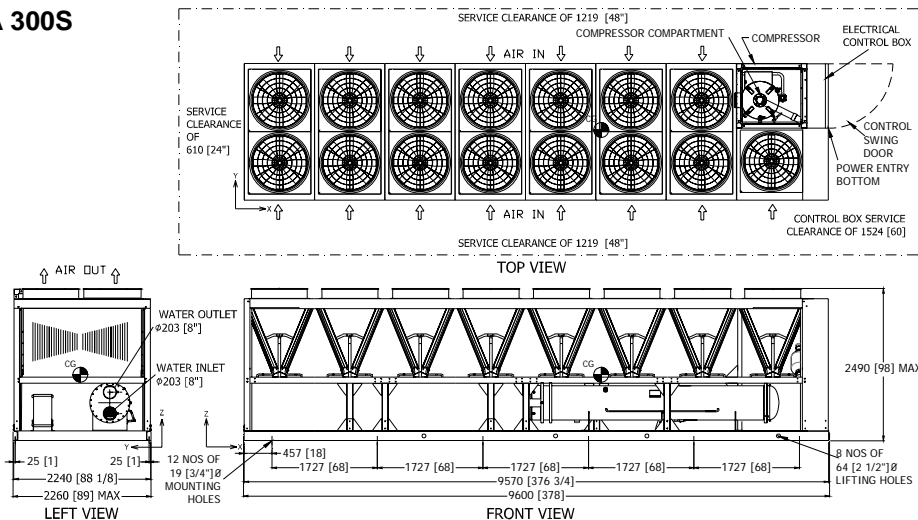

Note: All dimensions are in mm[inches].

DIMENSIONAL DATA

50Hz: AVX-A 340T
60Hz: AVX-A 300T, 330T

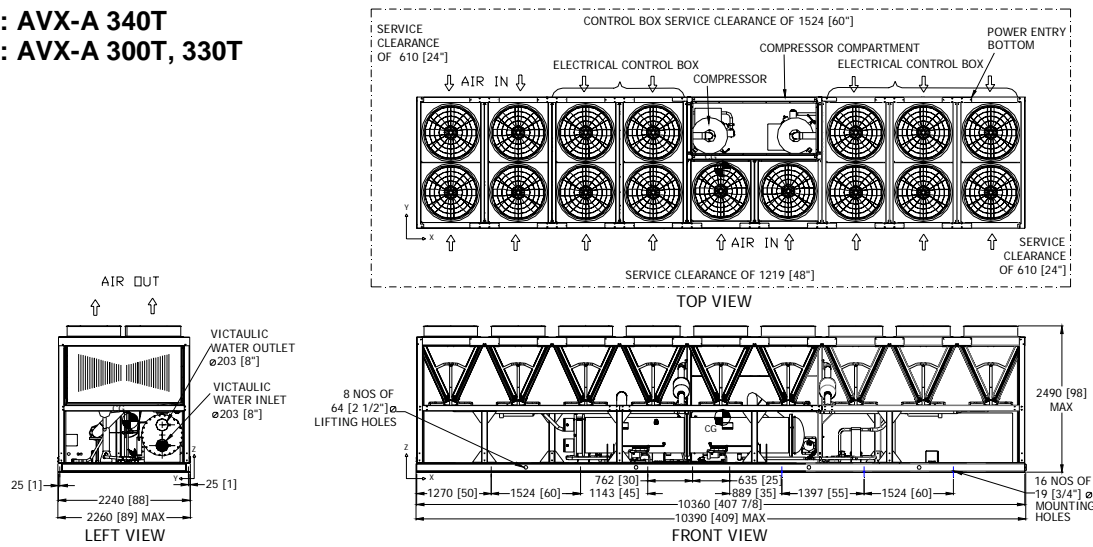

60Hz: AVX-A 350T, 380T

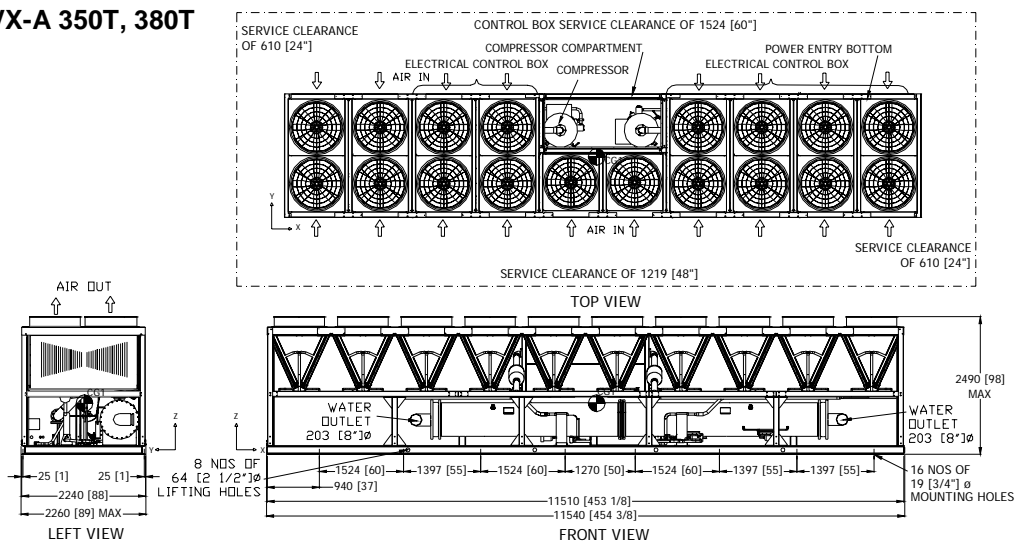

50Hz: AVX-A 365T

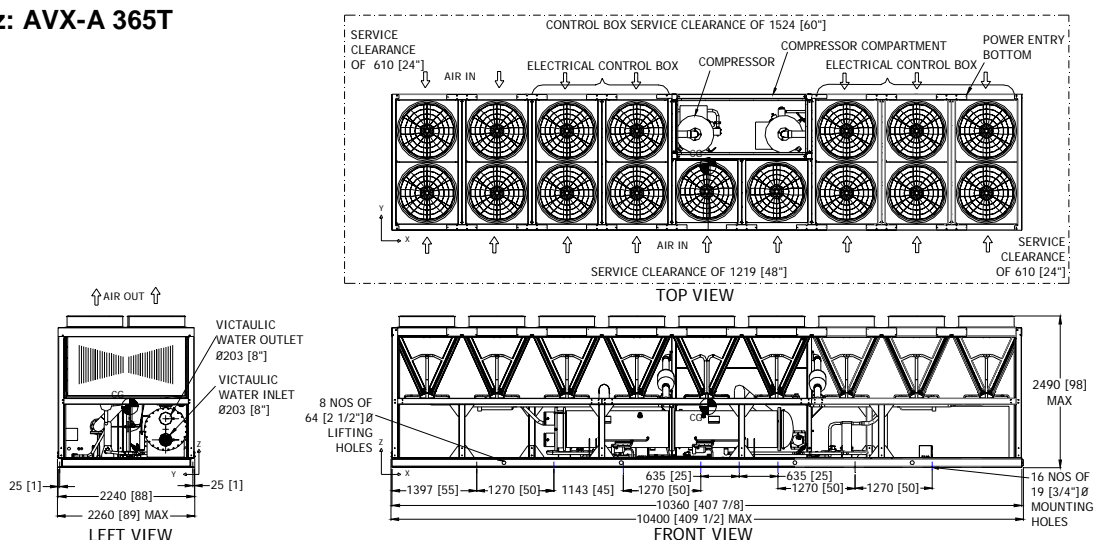

Note: All dimensions are in mm[inches].

DIMENSIONAL DATA

50/60Hz: AVX-A 400T

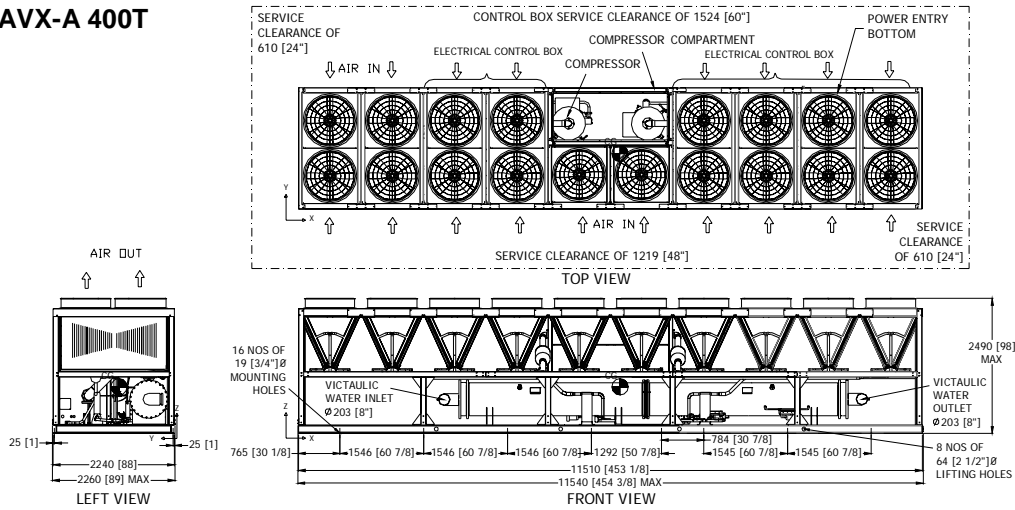

50Hz: AVX-A 450T, 520T

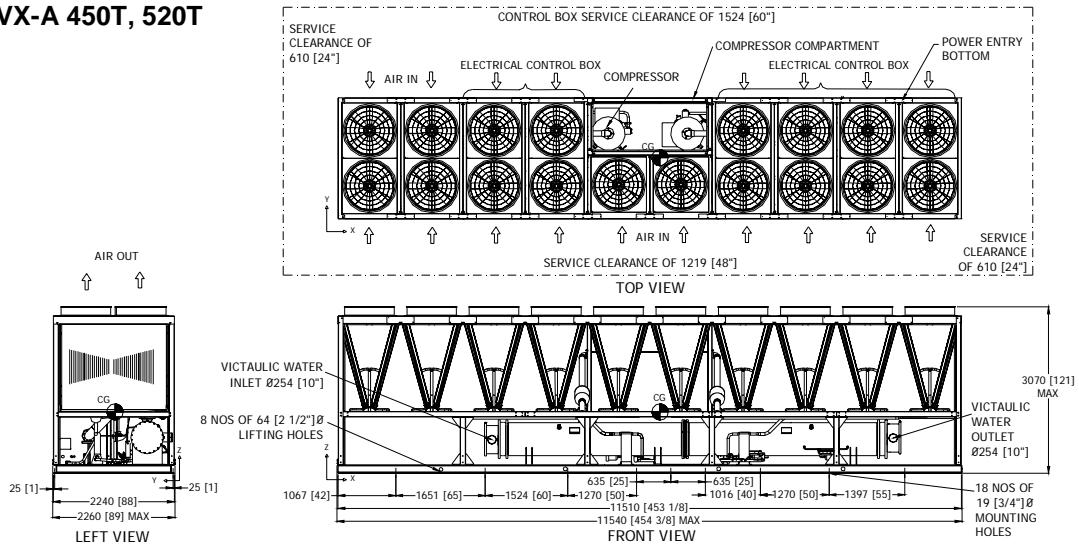

50Hz: AVX-A 450M 60Hz: AVX-A 440M AVX-A 470M

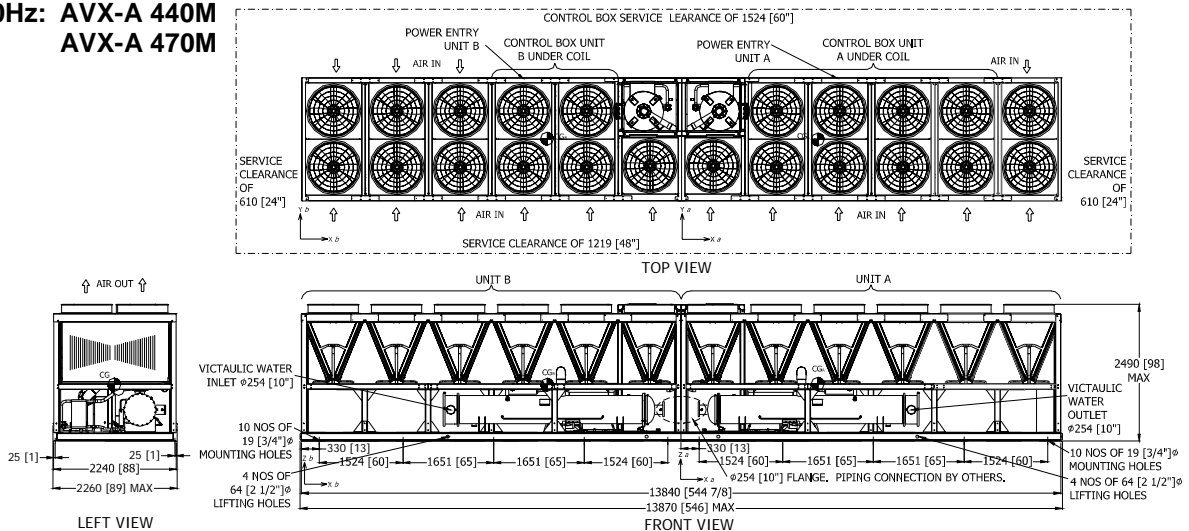

Note: All dimensions are in mm[inches].

DIMENSIONAL DATA

50Hz: AVX-A 490M

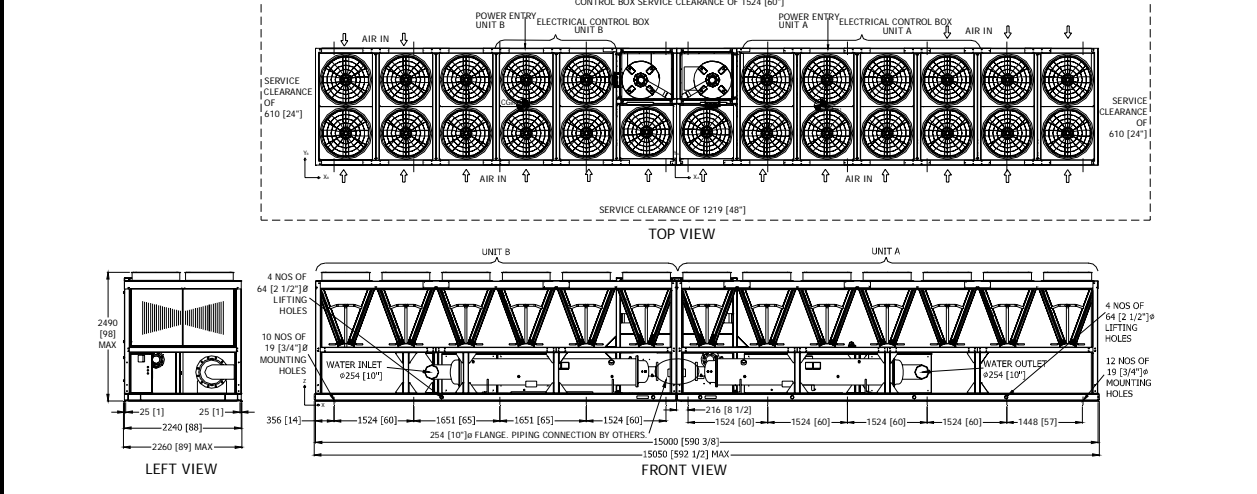

50Hz: AVX-A 520M

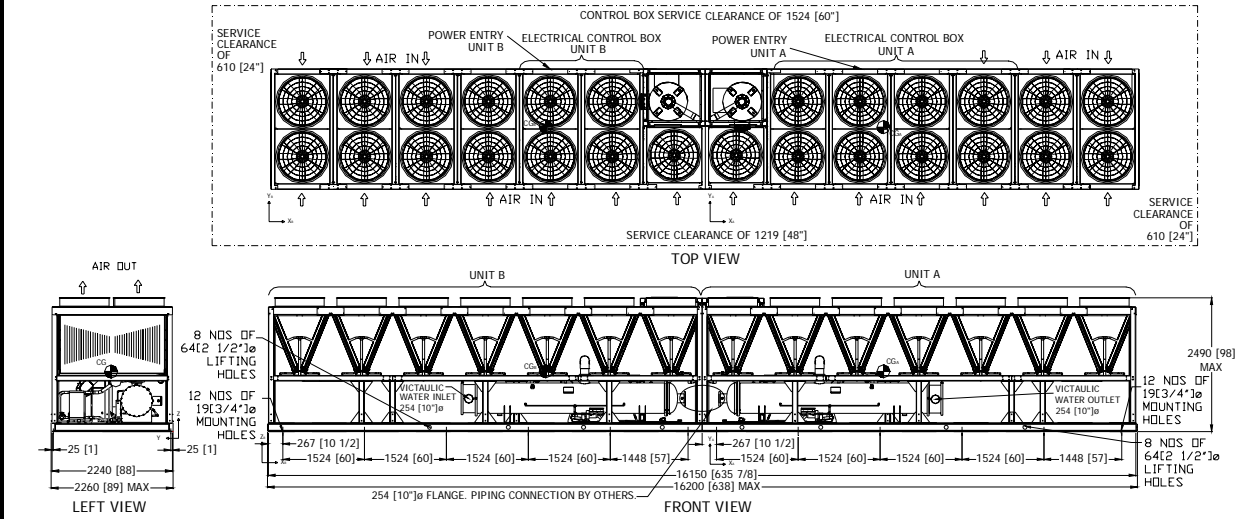

60Hz: AVX-A 540M

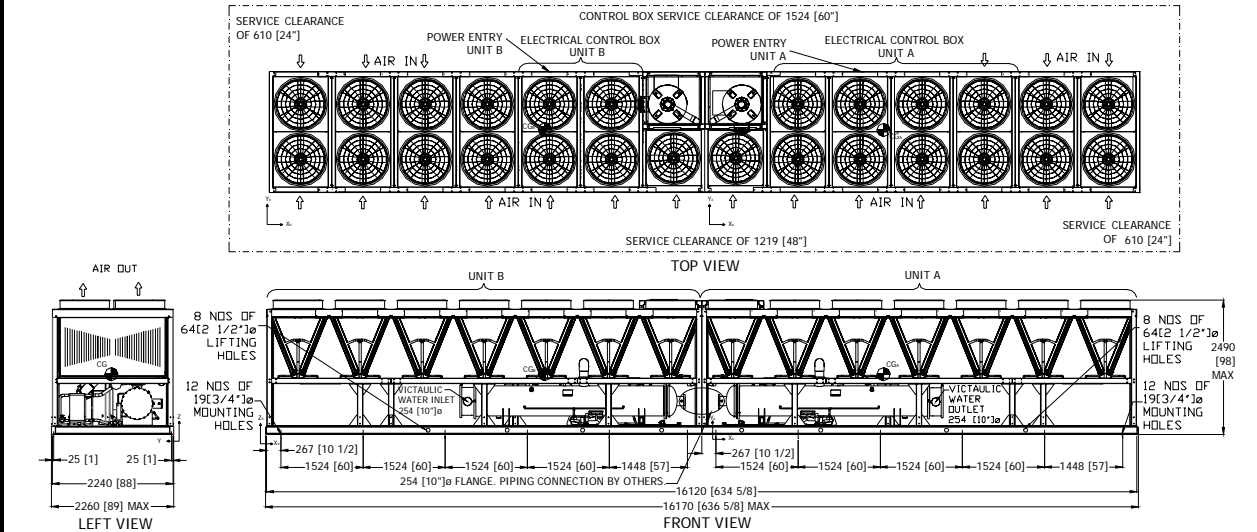

Note: All dimensions are in mm[inches].

FLOOR LOADING DIAGRAM

50Hz

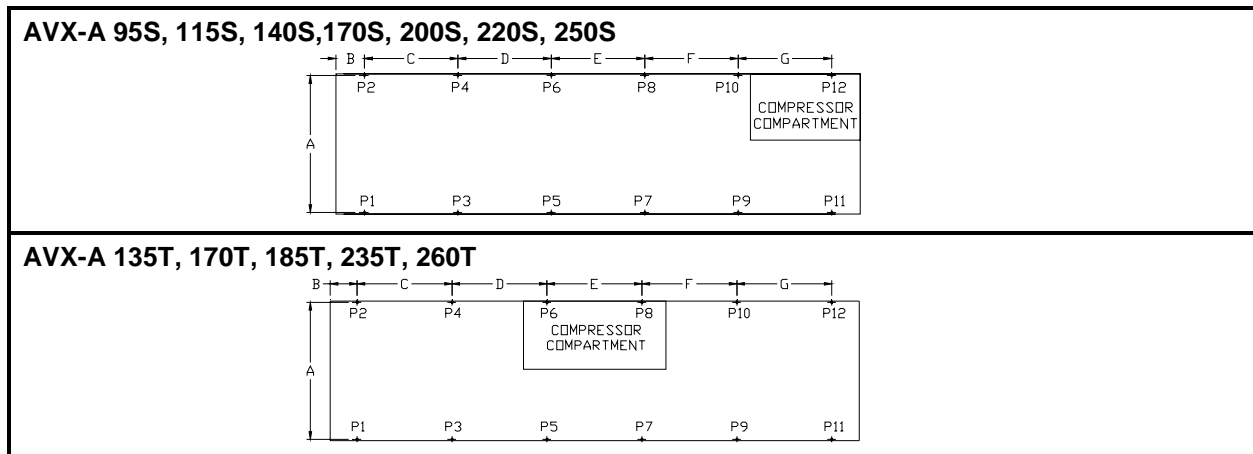

a.) Point Load Location – inches [mm]

Model AVX-A	Dimensions - Inches [mm]						
	A Dim.	B Dim.	C Dim.	D Dim.	E Dim.	F Dim.	G Dim.
95S	86 [2184]	13 3/4 [350]	56 1/4 [1430]	56 1/4 [1430]	-	-	-
115S	86 [2184]	10 [255]	55 1/8 [1400]	55 1/8 [1400]	55 1/8 [1400]	-	-
135T	86 [2184]	36 [914]	53 [1346]	53 [1346]	53 [1346]	-	-
140S	86 [2184]	10 [255]	55 1/8 [1400]	55 1/8 [1400]	55 1/8 [1400]	-	-
170S	86 [2184]	21 1/2 [545]	62 5/8 [1590]	62 5/8 [1590]	62 5/8 [1590]	-	-
170T	86 [2184]	25 [635]	61 [1549]	51 [1295]	51 [1295]	61 [1549]	-
185T	86 [2184]	40 [1016]	50 [1270]	46 [1168]	46 [1168]	50 [1270]	-
200S	86 [2184]	20 [508]	61 [1549]	61 [1549]	61 [1549]	61 [1549]	-
220S	86 [2184]	20 [508]	61 [1549]	61 [1549]	61 [1549]	61 [1549]	-
235T	86 [2184]	30 [762]	49 [1245]	49 [1245]	49 [1245]	49 [1245]	49 [1245]
250S	86 [2184]	17 7/8 [455]	59 [1499]	59 [1499]	59 [1499]	59 [1499]	59 [1499]
260T	86 [2184]	30 [762]	49 [1245]	49 [1245]	49 [1245]	49 [1245]	49 [1245]

b.) Point Load Data

Model AVX-A		Point Load												Operating Weight
		P1	P2	P3	P4	P5	P6	P7	P8	P9	P10	P11	P12	
95S	Lbs	970	812	1353	1286	1361	1718	-	-	-	-	-	-	7500
	kg	440	368	614	584	617	779	-	-	-	-	-	-	3402
115S	Lbs	789	633	1098	934	1416	1297	979	1351	-	-	-	-	8497
	kg	358	287	498	424	642	588	444	613	-	-	-	-	3854
135T	Lbs	1585	1051	1209	1352	1930	1640	976	1237	-	-	-	-	10979
	kg	719	477	548	613	875	744	443	561	-	-	-	-	4980
140S	Lbs	828	665	1155	985	1475	1352	1014	1387	-	-	-	-	8861
	kg	376	302	524	447	669	613	460	629	-	-	-	-	4019
170S	Lbs	805	786	1478	1048	1221	1118	1600	2139	-	-	-	-	10194
	kg	365	357	670	476	554	507	726	970	-	-	-	-	4624
170T	Lbs	1386	1013	1255	1258	1806	1625	986	1047	864	993	-	-	12232
	kg	629	460	569	571	819	737	447	475	392	450	-	-	5548
185T	Lbs	1826	1151	1247	1491	1854	1811	1076	1158	829	1104	-	-	13547
	kg	828	522	566	676	841	821	488	525	376	501	-	-	6145
200S	Lbs	829	821	908	864	1369	1133	1655	1541	1280	1852	-	-	12253
	kg	376	372	412	392	621	514	751	699	581	840	-	-	5558
220S	Lbs	852	851	947	908	1473	1221	1765	1697	1427	2156	-	-	13297
	kg	387	386	430	412	668	554	800	770	647	978	-	-	6032
235T	Lbs	1614	1068	1351	1270	1747	1537	1373	1501	925	1198	819	811	15215
	kg	732	485	613	576	792	697	623	681	420	543	371	368	6901
250S	Lbs	789	782	895	873	1081	999	1499	1262	2036	1885	1359	2009	15469
	kg	358	355	406	396	490	453	680	572	923	855	617	911	7017
260T	Lbs	1796	1117	1427	1293	1900	1585	1448	1542	958	1211	841	819	15938
	kg	815	507	647	587	862	719	657	700	435	549	382	372	7229

FLOOR LOADING DIAGRAM

50Hz

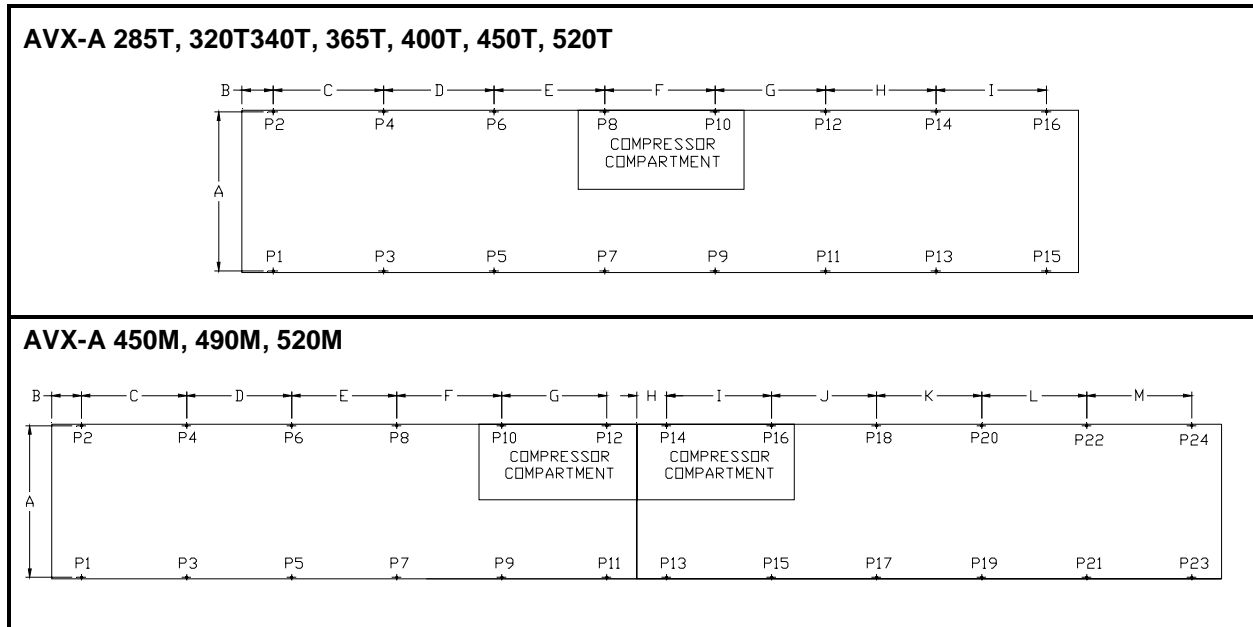

a.) Point Load Location – inches [mm]

Model AVX-A	Dimensions – Inches [mm]												
	A Dim.	B Dim.	C Dim.	D Dim.	E Dim.	F Dim.	G Dim.	H Dim.	I Dim.	J Dim.	K Dim.	L Dim.	M Dim.
285T	86 [2184]	47 5/8 [1210]	45 [1143]	25 [635]	45 [1143]	40 [1160]	30 [762]	65 [1651]	-	-	-	-	-
320T	86 [2184]	47 5/8 [1210]	45 [1143]	25 [635]	45 [1143]	40 [1160]	30 [762]	65 [1651]	-	-	-	-	-
340T	86 [2184]	50 [1270]	60 [1524]	45 [1143]	30 [761]	25 [636]	35 [889]	55 [1397]	60 [1524]	-	-	-	-
365T	86 [2184]	55 [1397]	50 [1270]	45 [1143]	55 [1397]	20 [508]	20 [508]	55 [1397]	50 [1270]	-	-	-	-
400T	86 [2184]	30 1/8 [765]	60 7/8 [1546]	60 7/8 [1546]	65 7/8 [1673]	45 7/8 [1165]	30 7/8 [784]	60 7/8 [1546]	60 7/8 [1546]	-	-	-	-
450T	86 [2184]	42 [1067]	65 [1651]	60 [1524]	50 [1270]	25 [635]	25 [635]	40 [1016]	50 [1270]	55 [1397]	-	-	-
520T	86 [2184]	42 [1067]	65 [1651]	60 [1524]	50 [1270]	25 [635]	25 [635]	40 [1016]	50 [1270]	55 [1397]	-	-	-
450M	86 [2184]	14 [356]	60 [1524]	65 [1651]	65 [1651]	60 [1524]	8 [203]	60 [1524]	65 [1651]	65 [1651]	60 [1524]	-	-
490M	86 [2184]	14 [356]	60 [1524]	65 [1651]	65 [1651]	60 [1524]	8 1/2 [216]	60 [1524]	60 [1524]	60 [1524]	60 [1524]	57 [1448]	-
520M	86 [2184]	11 3/4 [299]	57 [1448]	60 [1524]	60 [1524]	60 [1524]	60 [1524]	8 1/2 [216]	60 [1524]	60 [1524]	60 [1524]	60 [1524]	57 [1448]

b.) Point Load Data

Model AVX-A		Point Load																								Operating Weight
		P1	P2	P3	P4	P5	P6	P7	P8	P9	P10	P11	P12	P13	P14	P15	P16	P17	P18	P19	P20	P21	P22	P23	P24	
285T	Lbs	871	741	1624	959	1203	1062	1483	1476	1829	1783	997	1039	970	1217	-	-	-	-	-	-	-	-	-	-	17253
	kg	395	336	737	435	546	482	673	669	830	809	452	471	440	552	-	-	-	-	-	-	-	-	-	-	7826
320T	Lbs	913	755	1786	1004	1261	1082	1561	1507	1970	1899	1047	1074	992	1231	-	-	-	-	-	-	-	-	-	-	18082
	kg	414	343	810	456	572	491	708	683	894	861	475	487	450	558	-	-	-	-	-	-	-	-	-	-	8202
340T	Lbs	852	745	1452	1016	1435	1043	1196	1139	1546	1470	2022	1885	1022	1112	807	907	-	-	-	-	-	-	-	-	19650
	kg	387	338	659	461	651	473	543	517	701	667	917	855	464	505	366	412	-	-	-	-	-	-	-	-	8913
365T	Lbs	892	778	1275	920	1496	997	1610	1780	1721	1248	1742	1792	946	1042	832	987	-	-	-	-	-	-	-	-	20058
	kg	405	353	578	417	679	452	730	807	781	566	790	813	429	473	377	448	-	-	-	-	-	-	-	-	9098
400T	Lbs	955	871	1336	1010	1484	1319	2222	1875	1878	2008	1405	1467	1237	995	961	895	-	-	-	-	-	-	-	-	21919
	kg	433	395	606	458	673	598	100	851	852	911	637	665	561	452	436	406	-	-	-	-	-	-	-	-	9942
450T	Lbs	951	945	1347	1268	1486	1627	1554	1740	1840	1942	1904	1814	1197	1136	1307	1070	1044	1052	-	-	-	-	-	-	25225
	kg	431	429	611	575	674	738	705	789	835	881	864	823	543	515	593	485	474	477	-	-	-	-	-	-	11442
520T	Lbs	1061	1037	1525	1399	1650	1753	1721	1860	2055	2084	2147	1960	1336	1241	1489	1180	1176	1147	-	-	-	-	-	-	27821
	kg	481	471	692	635	748	795	780	844	932	945	974	889	606	563	675	535	533	520	-	-	-	-	-	-	12619
450M	Lbs	766	772	1034	1018	1711	1388	1885	1939	1512	2044	1417	1925	1928	1787	1746	1686	1040	999	776	765	-	-	-	-	28138
	kg	348	350	469	462	776	629	855	880	686	927	643	873	875	810	792	765	472	453	352	347	-	-	-	-	12763
490M	Lbs	789	781	1074	1035	1885	1459	1999	1986	1589	2076	1592	2085	1934	1780	1740	1482	1051	971	1004	977	688	674	-	-	30,582
	kg	358	354	487	469	855	662	907	901	721	941	7222	946	877	807	789	672	477	441	455	443	312	306	-	-	13,872
520M	Lbs	708	695	1052	996	1174	995	1811	1381	1786	1810	1482	2093	1592	2085	1935	1780	1741	1483	1052	971	1004	977	688	674	31965
	kg	321	315	477	452	532	451	821	626	810	821	672	949	722	946	878	807	790	673	477	441	455	443	312	306	14499



FLOOR LOADING DIAGRAM

60Hz

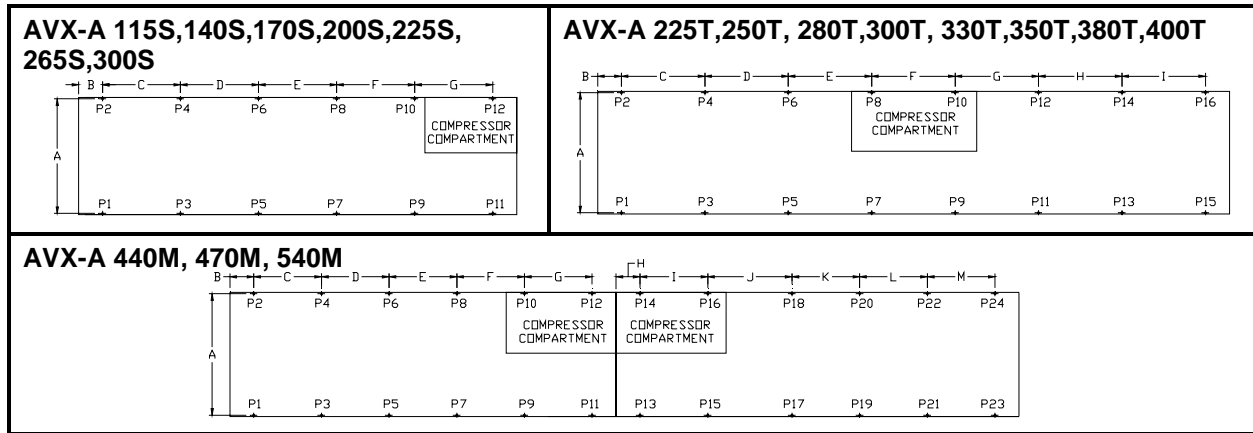

a.) Point Load Location – inches [mm]

Model AVX-A	Dimensions - Inches [mm]												
	A Dim.	B Dim.	C Dim.	D Dim.	E Dim.	F Dim.	G Dim.	H Dim.	I Dim.	J Dim.	K Dim.	L Dim.	M Dim.
115S	86 [2184]	10 [255]	55 1/8 [1400]	55 1/8 [1400]	55 1/8 [1400]	-	-	-	-	-	-	-	-
140S	86 [2184]	10 [255]	55 1/8 [1400]	55 1/8 [1400]	55 1/8 [1400]	-	-	-	-	-	-	-	-
170S	86 [2184]	21 1/2 [545]	62 5/8 [1590]	62 5/8 [1590]	62 5/8 [1590]	-	-	-	-	-	-	-	-
200S	86 [2184]	20 [508]	61 [1549]	61 [1549]	61 [1549]	61 [1549]	-	-	-	-	-	-	-
225S	86 [2184]	20 [508]	61 [1549]	61 [1549]	61 [1549]	61 [1549]	-	-	-	-	-	-	-
225T	86 [2184]	30 [762]	49 [1245]	49 [1245]	49 [1245]	49 [1245]	49 [1245]	-	-	-	-	-	-
250T	86 [2184]	47 5/8 [1210]	45 [1143]	25 [635]	45 [1143]	40 [1160]	30 [762]	65 [1651]	-	-	-	-	-
265S	86 [2184]	17 7/8 [455]	59 [1499]	59 [1499]	59 [1499]	59 [1499]	59 [1499]	59 [1499]	-	-	-	-	-
280T	86 [2184]	47 5/8 [1210]	45 [1143]	25 [635]	45 [1143]	40 [1160]	30 [762]	65 [1651]	-	-	-	-	-
300S	86 [2184]	18 [457]	68 [1727]	68 [1727]	68 [1727]	68 [1727]	68 [1727]	-	-	-	-	-	-
300T	86 [2184]	50 [1270]	60 [1524]	45 [1143]	30 [761]	25 [636]	35 [889]	55 [1397]	60 [1524]	-	-	-	-
330T	86 [2184]	50 [1270]	60 [1524]	45 [1143]	30 [761]	25 [636]	35 [889]	55 [1397]	60 [1524]	-	-	-	-
350T	86 [2184]	37 [940]	60 [1524]	55 [1397]	65 [1651]	45 [1143]	60 [1524]	55 [1397]	55 [1397]	-	-	-	-
380T	86 [2184]	37 [940]	60 [1524]	55 [1397]	65 [1651]	45 [1143]	60 [1524]	55 [1397]	55 [1397]	-	-	-	-
400T	86 [2184]	30 1/8 [765]	60 7/8 [1546]	60 7/8 [1546]	65 7/8 [1673]	45 7/8 [1165]	30 7/8 [784]	60 7/8 [1546]	60 7/8 [1546]	-	-	-	-
440M	86 [2184]	14 [356]	60 [1524]	65 [1651]	65 [1651]	60 [1524]	8 [203]	60 [1524]	65 [1651]	65 [1651]	60 [1524]	-	-
470M	86 [2184]	14 [356]	60 [1524]	65 [1651]	65 [1651]	60 [1524]	8 [203]	60 [1524]	65 [1651]	65 [1651]	60 [1524]	-	-
540M	86 [2184]	11 3/4 [299]	57 [1448]	60 [1524]	60 [1524]	60 [1524]	60 [1524]	8 1/2 [216]	60 [1524]	60 [1524]	60 [1524]	60 [1524]	57 [1448]

b.) Point Load Data

Model AVX-A		Point Load																								Operating Weight
		P1	P2	P3	P4	P5	P6	P7	P8	P9	P10	P11	P12	P13	P14	P15	P16	P17	P18	P19	P20	P21	P22	P23	P24	
115S	Lbs	785	629	1097	921	1410	1292	983	1351	-	-	-	-	-	-	-	-	-	-	-	-	-	-	-	-	8468
	kg	356	285	498	418	640	586	446	613	-	-	-	-	-	-	-	-	-	-	-	-	-	-	-	-	3841
140S	Lbs	819	658	1152	978	1457	1329	1007	1364	-	-	-	-	-	-	-	-	-	-	-	-	-	-	-	-	8764
	kg	372	299	522	443	661	603	457	619	-	-	-	-	-	-	-	-	-	-	-	-	-	-	-	-	3975
170S	Lbs	775	767	1558	1065	1233	1101	1486	2008	-	-	-	-	-	-	-	-	-	-	-	-	-	-	-	-	9994
	kg	352	348	707	483	559	499	674	911	-	-	-	-	-	-	-	-	-	-	-	-	-	-	-	-	4533
200S	Lbs	826	812	904	852	1362	1114	1639	1496	1244	1753	-	-	-	-	-	-	-	-	-	-	-	-	-	-	12004
	kg	375	369	410	387	618	505	743	678	564	795	-	-	-	-	-	-	-	-	-	-	-	-	-	-	5445
225S	Lbs	844	827	935	875	1454	1168	1717	1566	1323	1870	-	-	-	-	-	-	-	-	-	-	-	-	-	-	12579
	kg	383	375	424	397	660	530	779	710	600	848	-	-	-	-	-	-	-	-	-	-	-	-	-	-	5706
225T	Lbs	1607	1061	1348	1267	1747	1536	1372	1500	911	1183	818	810	-	-	-	-	-	-	-	-	-	-	-	-	15162
	kg	729	481	612	575	792	697	623	681	413	537	371	368	-	-	-	-	-	-	-	-	-	-	-	-	6877
250T	Lbs	851	733	1538	915	1175	1045	1448	1443	1793	1766	981	1027	959	1205	-	-	-	-	-	-	-	-	-	-	16879
	kg	386	332	697	415	533	474	657	655	814	801	445	466	435	547	-	-	-	-	-	-	-	-	-	-	7656
265S	Lbs	787	777	892	867	1078	991	1495	1249	2023	1850	1339	1953	-	-	-	-	-	-	-	-	-	-	-	-	15301
	kg	357	353	405	393	489	450	678	566	918	839	607	886	-	-	-	-	-	-	-	-	-	-	-	-	6941
280T	Lbs	858	735	1578	941	1184	1048	1451	1443	1786	1739	982	1025	963	1212	-	-	-	-	-	-	-	-	-	-	16943
	kg	389	333	716	427	537	475	658	654	810	789	445	465	437	550	-	-	-	-	-	-	-	-	-	-	7685
300S	Lbs	894	1040	889	952	1085	1127	2194	1559	2052	2144	1361	1671	-	-	-	-	-	-	-	-	-	-	-	-	16969
	kg	406	472	403	432	492	511	995	707	931	973	618	758	-	-	-	-	-	-	-	-	-	-	-	-	7697
300T	Lbs	849	745	1480	1005	1383	1041	1237	1265	1513	1333	1833	1683	1008	1097	803	908	-	-	-	-	-	-	-	-	19184
	kg	385	338	671	456	627	472	561	574	686	605	831	763	457	498	364	412	-	-	-	-	-	-	-	-	8702
330T	Lbs	856	745	1516	1031	1401	1035	1234	1219	1521	1298	1860	1681	1023	1117	807	907	-	-	-	-	-	-	-	-	19253
	kg	388	338	688	468	636	470	560	553	690	589	844	763	464	507	366	412	-	-	-	-	-	-	-	-	8733
350T	Lbs	925	837	1441	1023	1427	1267	2211	1829	1913	1990	1377	1454	1078	901	907	831	-	-	-	-	-	-	-	-	21413
	kg	420	380	654	464	647	575	100	830	868	903	624	660	489	409	411	377	-	-	-	-	-	-	-	-	9713
380T	Lbs	924	829	1444	1021	1419	1236	2192	1748	1892	1894	1391	1448	1086	894	909	825	-	-	-	-	-	-	-	-	21154
	kg	419	376	655	463	644	561	994	793	858	859	631	657	492	406	412	374	-	-	-	-	-	-	-	-	9595
400T	Lbs	949	858	1328	990	1467	1276	2183	1780	1829	1887	1391	1434	1230	978	957	883	-	-	-	-	-	-	-	-	21421
	kg	431	389	603	449	665	579	990	807	830	856	631	651	558	444	434	401	-	-	-	-	-	-	-	-	9716
440M	Lbs	754	740	1017	975	1679	1317	1817	1763	1366	1648	1311	1638	1875	1650	1720	1631	1027	967	767	741	-	-	-	-	26402
	kg	342	336	461	442	762	597	824	800	619	748	595	743	850	748	780	740	466	438	348	336	-	-	-	-	11976
470M	Lbs	758	749	1022	987	1692	1337	1838	1810	1406	1751	1314	1640	1879	1652	1727	1634	1029	967	767	741	-	-	-	-	26700
	kg	344	340	464	448	768	607	834	821	638	794	596	744	852	749	783	741	467	439	348	336	-	-	-	-	12111
540M	Lbs	706	691	1050	991	1171	987	1807	1369	1776	1783	1458	2026	1569	2020	1925	1751	1737	1471	1049	964	1002	971	687	670	31630
	kg	320	313	476	450	531	448	819	621	805	809	661	919	712	916	873	794	788	667	476	437	454	441	312	304	14347

FIELD POWER & CONTROL WIRING SCHEMATIC

TYPICAL FIELD WIRING DIAGRAM

1 COMPRESSOR

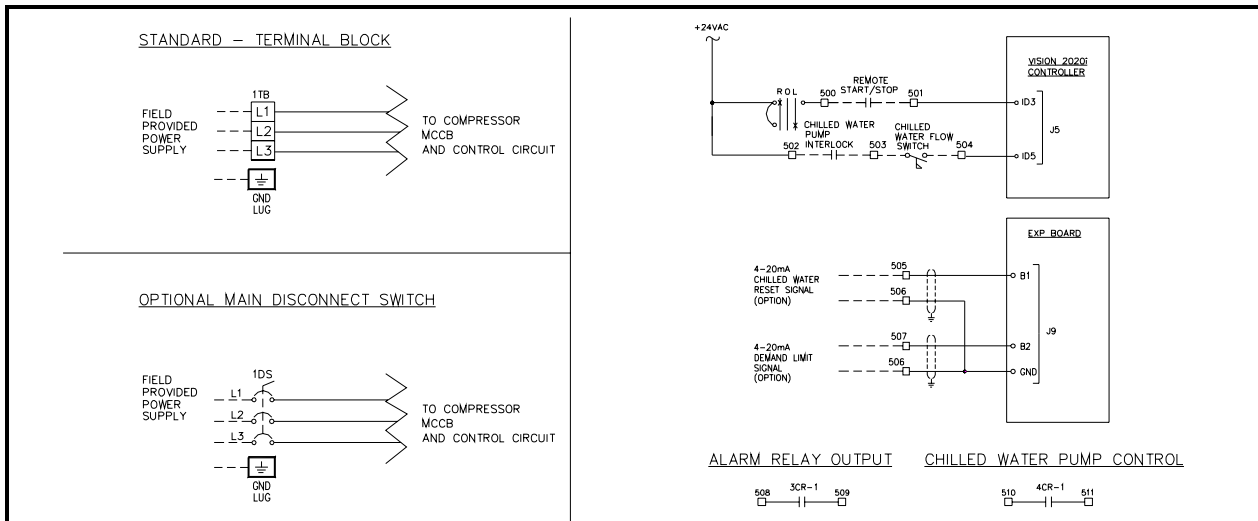

2 COMPRESSORS

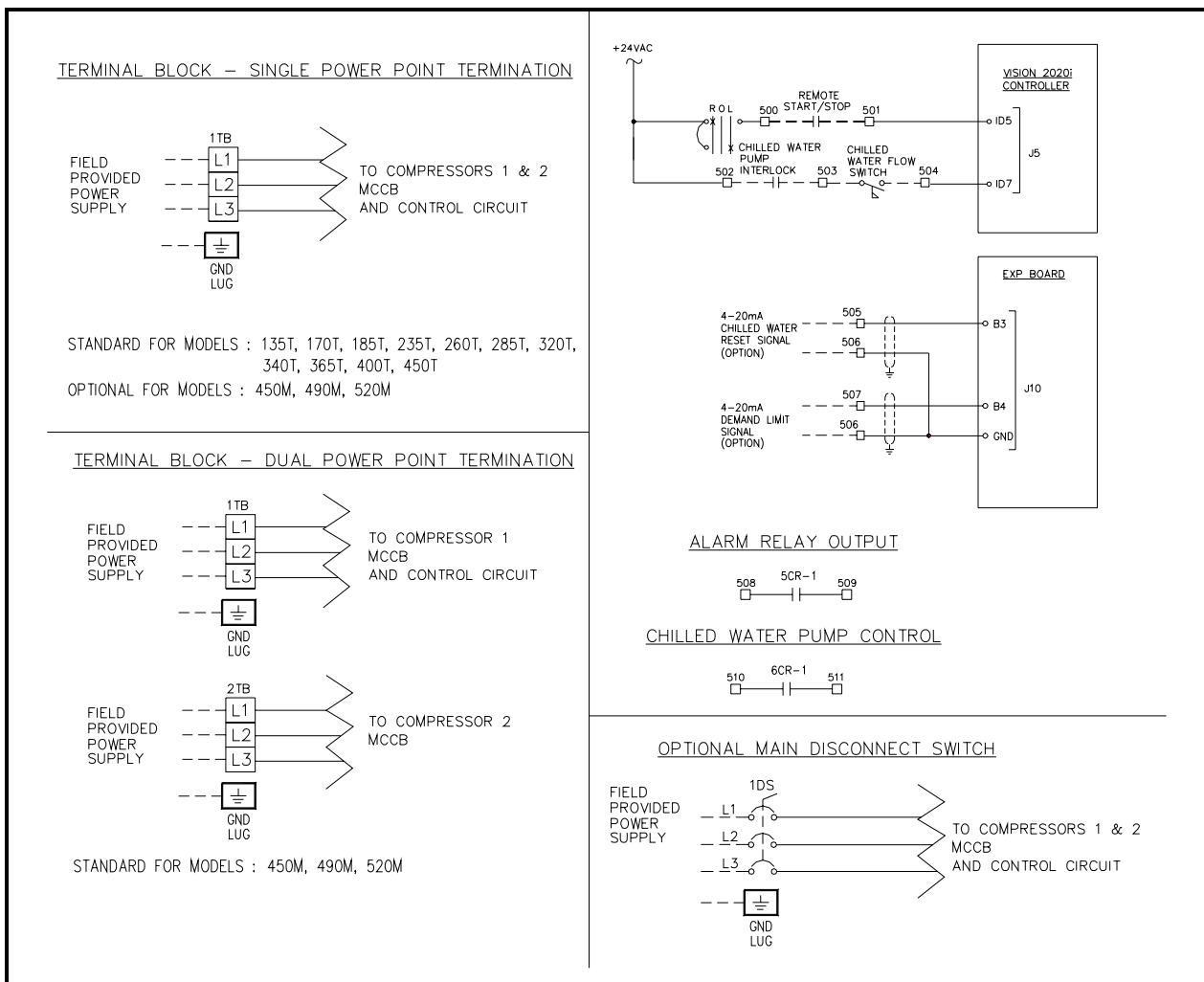

APPLICATION DATA

UNIT DESIGNED OPERATING RANGE

Unit Operating Range – Ambient Temperature

The units are designed to operate at ambient temperature, 45~125°F [7~52°C]. If the unit requires to be operated at lower ambient temperature, the optional Low Ambient Operation (LA 1), or Extra Low Ambient Operation (LA 2) shall be incorporated for stable operation.

Operating Limits – Ambient Temperature

Operating Ambient Temperature	Minimum	Maximum
Standard	45°F [7°C]	125°F [52°C]
With LA 1	14°F [-10°C]	125°F [52°C]
With LA 2	-20°F [-29°C]	125°F [52°C]

If wind velocity in the area is over 5 mph [8 kmph], wind barrier is recommended.

Unit Operating Range – Evaporator Temperature

The unit is designed to deliver chilled fluid temperature within 40~50°F [4.5~10°C]. The unit can start and pull down with up to 80°F [27°C] entering-fluid temperature. For sustained operation, it is recommended that the entering fluid temperature not exceed 70°F [21°C].

For unit installation with minimum ambient temperature at 32°F [0°C] or below, Evaporator Anti-Freeze Protection option is recommended to prevent freezing of water in evaporator when the chiller is not in operation.

Operating Limits – Leaving Fluid Temperature

Leaving Fluid Temperature	Minimum	Maximum
Standard	40 °F [4.5 °C]	50 °F [10 °C]
Dual Mode / Low Temp. Operation	18 °F [-7.8 °C]	50 °F [10 °C]

EVAPORATOR FLUID CIRCUIT

Wide Range ΔT - Low Flow Applications

Multiple smaller chillers may be applied in series, each providing a portion of the design temperature range typical 10°F [5.5°C] each.

Chilled fluid may be recirculated through the evaporator as shown below to allow the chiller to operate with acceptable flow rates and temperature ranges (Figure 1A).

Figure 1A

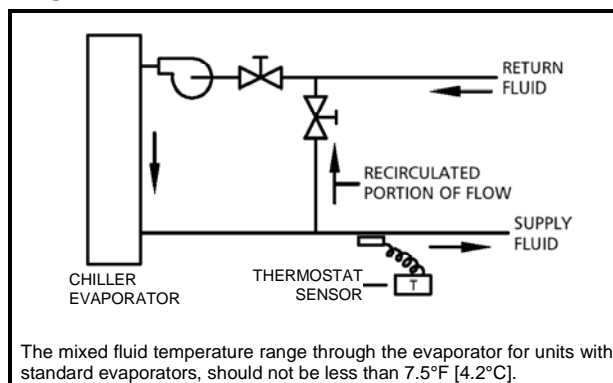

Narrow Range ΔT - High Flow Applications

For Narrow Range ΔT applications, a partial evaporator bypass piping and valve configuration can be used as shown below.

This permits a higher ΔT and lower ΔP (pressure drop) through the evaporator (Figure 1B).

Figure 1B

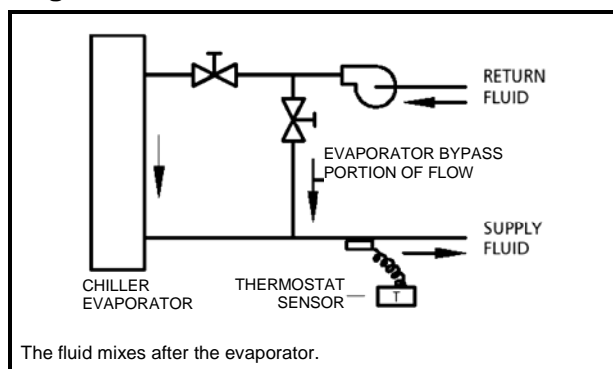

Minimum Chilled Fluid Loop Volume

The evaporator fluid circuit requires a minimum system fluid volume of 3 US gallons per Ton [3.3 liters/ cooling kW] for stable operation. The minimum system fluid volume may increase up to 10 US gallons per Ton [11 liters/ cooling kW] for process cooling, low load applications with small temperature range and/or vastly fluctuating load conditions.

Tanks for System Volume Enhancement

It may be necessary to install a tank in the system to provide sufficient system fluid volume, as shown below. The tank should be baffled and piped for proper fluid mixing to prevent stratification.

Figure 2A

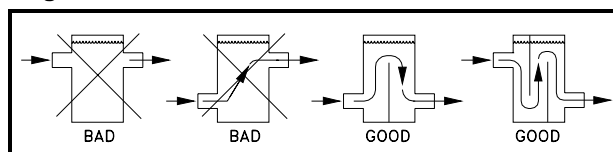

APPLICATION DATA

Figure 2B Single Loop System with Storage Tank to Increase Loop Volume

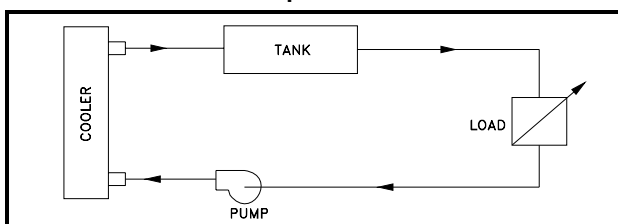
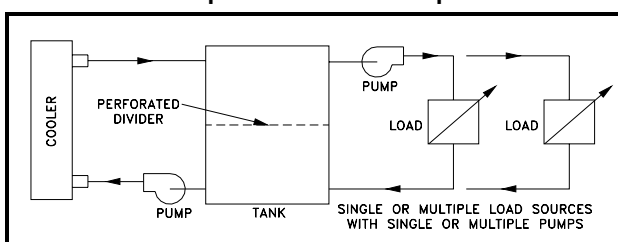

Figure 2C Primary and Secondary Loop Systems are normally used where the secondary system has variable flow and/or multiple loads. See example below.



Multiple Chillers In A Chilled Water System

Where the load is greater than available from one Achelous AVX-A, where standby capacity is required or the load profile dictates, multiple chillers may be piped in parallel. Units of equal size help to ensure fluid flow balance, but balancing valves ensure balanced flows even with dissimilar sized chillers.

Temperature controller sensors may or may not need to be moved to the common fluid piping depending on the specific application.

Parallel Chiller Applications – Both units operate simultaneously modulating with load variations. Each unit operates independently sensing its own leaving fluid temperature. The set point of each thermostat is set to maintain the desired loading scheme. (Figure 3A)

Figure 3A

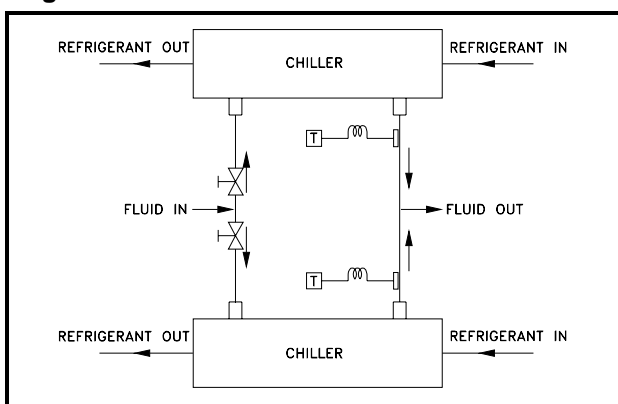

Series Chiller Applications – Where a large temperature range is required (over 25 °F [13.9 °C]), the chiller may be piped in series. In this case the units

are controlled independently. The load is progressive by temperature so the chiller selections are critical. (Figure 3B)

Figure 3B

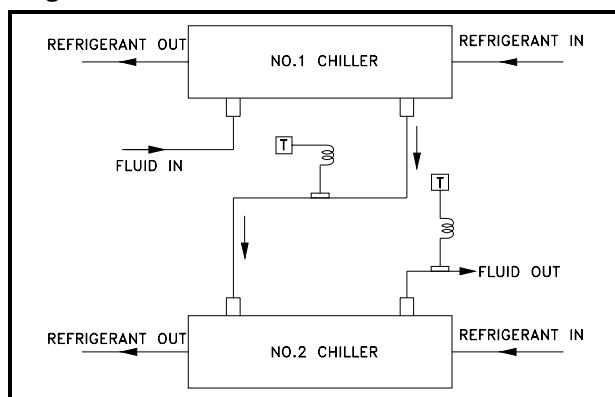

Variable Evaporator Flow

Dunham-Bush chillers are capable for variable evaporator flow system. The chiller may operate to maintain constant leaving fluid temperature with evaporator flow rate changes, with below conditions fulfilled.

- Evaporator fluid flow rate is within minimum and maximum flow rate of the unit at all time during the operation
- Rate of flow changed shall not exceeded 10% per minute

Failure to comply with the above conditions will cause problem to the chiller operation and may cause the chiller to shutdown.

Sound and Vibration

The compressors in AVX-A units are resiliently, mounted to reduce the transmission of any noise and vibration to the frame.

The compressors are not mounted on springs because extra movement may cause line breakage and refrigerant leaks. Unit isolation helps prevent any remaining sound or vibration from entering the building structure, piping or electrical service.

Glycol Freeze Protection

If the chiller or fluid piping may be exposed to temperatures below freezing, glycol protection is recommended if the water is not drained. The recommended protection is 10°F [5.6°C] below the minimum ambient temperature in the equipment room and around piping. Use only glycol solutions approved for heat exchanger duty. DO NOT use automotive anti-freezing.

If the equipment is being used to supply chilled fluid 38°F [3.3°C] or below, glycol should be used to prevent freeze damage. The freeze protection level should be 15°F [8.3°C] lower than the leaving brine temperature.

The use of glycol causes a performance derate as shown below which needs to be included in the unit selection procedure.

APPLICATION DATA

Table 1 : Ethylene Glycol

% E. G. By Weight	Freeze Point		C1 Capacity Factor	K1 kW Rate	G1 Flow Factor	P1 P.D. Factor
	°F	°C				
10	26.2	-3.2	0.995	0.998	1.019	1.050
15	22.4	-5.3	0.991	0.997	1.030	1.083
20	17.8	-7.9	0.988	0.996	1.044	1.121
25	12.6	-10.8	0.984	0.995	1.060	1.170
30	6.7	-14.1	0.981	0.994	1.077	1.219
35	0.0	-17.8	0.977	0.992	1.097	1.275
40	-10.0	-23.3	0.973	0.991	1.116	1.331
45	-17.5	-27.5	0.968	0.990	1.138	1.398
50	-28.9	-33.8	0.964	0.989	1.161	1.466

Table 2 : Propylene Glycol

% P. G. By Weight	Freeze Point		C2 Capacity Factor	K2 kW Rate	G2 Flow Factor	P2 P.D. Factor
	°F	°C				
10	26.1	-3.3	0.988	0.994	1.005	1.019
15	22.8	-5.1	0.984	0.992	1.008	1.031
20	19.1	-7.2	0.978	0.990	1.010	1.051
25	14.5	-9.7	0.970	0.988	1.015	1.081
30	8.9	-12.8	0.962	0.986	1.021	1.120

Table 3 : Correction Factor - Elevation

Elevation above Sea Level		Capacity Correction Factor	kW Correction Factor
Feet [m]	Meters Factor		
0	0	1.00	1.00
2000	600	0.99	1.01
4000	1200	0.98	1.02
6000	1800	0.97	1.03

Table 4 : Correction Factor - FF

Fouling Factor		Capacity Correction Factor	kW Correction Factor
Hr.ft².°F/BTU	m².°C/kW		
0.0001	0.018	1.000	1.000
0.00025	0.044	0.993	0.997
0.00050	0.088	0.978	0.990
0.00100	0.176	0.951	0.978

Note: P.D. – Pressure drop across evaporator

Piping Installation – Modular Chillers

Some chiller models are with modular design where the two single pass evaporators need to be connected at field after units have been aligned and levelled, and isolators are installed and adjusted (if any).

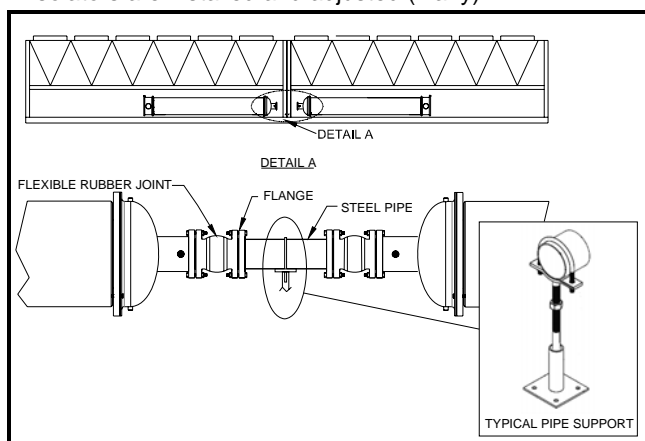

Evaporator header is come with ANSI flanged connection as standard at the interconnection end of the evaporators. Other type of connection can be arranged upon request. It is recommended to install

flexible rubber joint at the connection to avoid any excessive vibration being transferred to the flange connection and cause water leakage. The flexible rubber joints shall be installed within allowable movements of elongation, compression, eccentricity & angular movement. It is also recommended to include external support for this connection to avoid excessive stress on the evaporator head. Flexible joints, insulated steel pipe and other accessories for this connection are field supplied items. The entire connection piping shall be insulated upon completion of water loop testing. Illustrates recommended connection piping installation for modular chiller.

ICE THERMAL STORAGE SYSTEM (*ITES*)

The globe is progressively marching towards a serious electric energy crisis. The HVAC/R industry is shifting to operate with more efficient machines, as well as alternate system designs and solutions. Dunham-Bush, as a leader of HVAC/R solutions provider, we provide packaged solution for *ITES*, which include, equipments selections, chillers, Ice Cels and *CPM* for *ITES* system controls.

Dunham-Bush Chillers, with positive displacement rotary screw compressor can easily cool low temperature glycol down to 20°F [-6.7 °C] to charge the ice storage tanks. The same chiller can also produce warmer supply fluid temperature, 40 to 45 °F [4.4 to 7.2 °C], for those building systems designed for only peak shaving.

Dunham-Bush is the only HVAC/R manufacturer who can provide complete *ITES* packaged solution, with own products for chillers, ice storage tanks and plant room control system, with following benefits.

Demand Charge: *ITES* allows some of the peak demand to be shifted to low-demand nighttime periods, thus reducing demand charges for the entire year.

Energy Cost: *ITES*, by operating chillers at night, will fully utilize incentive on electricity night tariff, which is much lower compare to day tariff

Rebates: *ITES* usually qualifies for rebates offered by electric utilities or governments for equipment that shift peak loads to off-peak hours

Colder Air Temperature: *ITES* can produce chilled liquid at supply temperature of 38°F [3.3°C] or even lower without scarifying system's efficiencies. This realizes energy saving on chilled water pumping system, AHUs and FCUs. Colder supply air distribution lowers room humidity, and thus, comfort cooling can be achieved with higher room temperature. This reduce air conditioning load required, and therefore, reduces the installation cost and system operating cost.

Standby Cooling Capacity: Energy stored in *ITES* can be utilized to cater peak or unexpected loads which exceeded total cooling capacity available from the installed chillers. This is savior to the regions which having difficulties on power generation plants expansion, where with *ITES*, will significantly reduced total demand of the buildings.

MINIMUM CLEARANCE REQUIREMENTS

Single Pit (See Note 2)

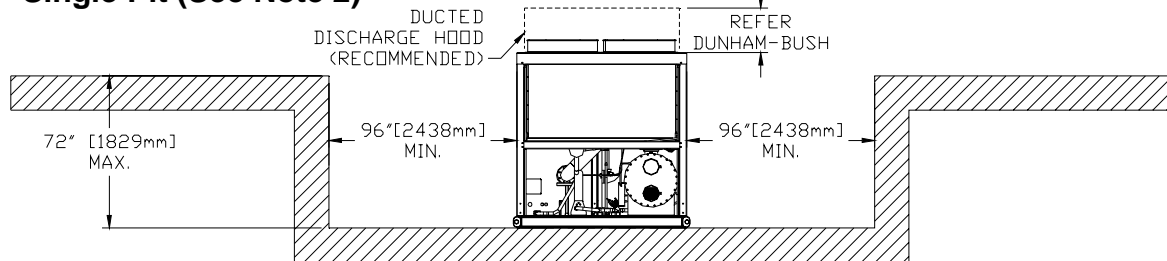

Double Pit (See Note 2)

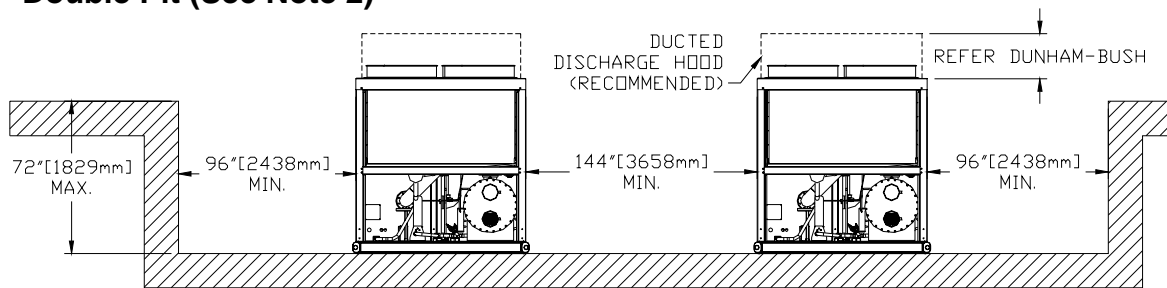

Multi Pit

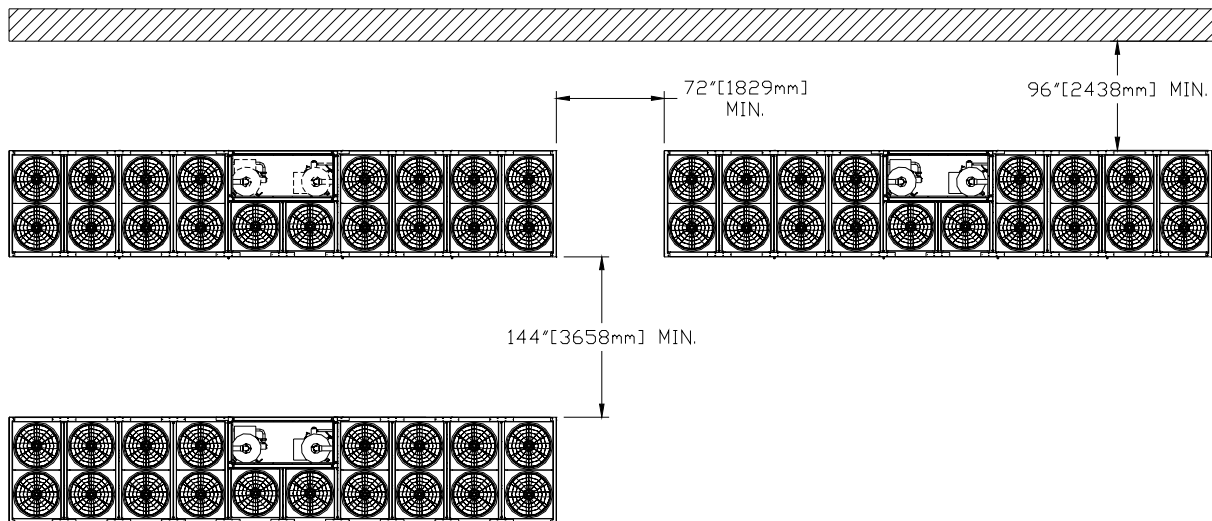

Corner Wall

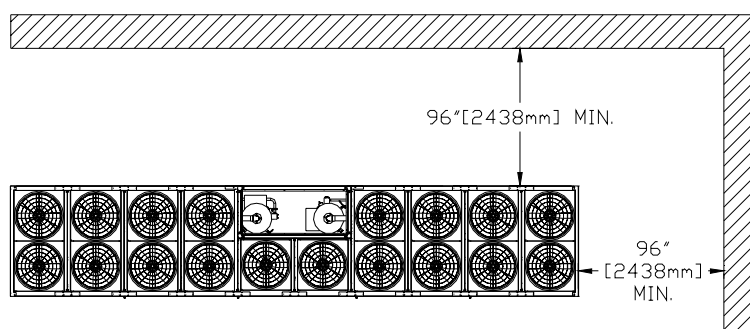

Notes:

- 1.) All dimensions are minimal, unless otherwise noted.
- 2.) Pit installations are not recommended. Re-circulation of hot condenser air in combination with surface air turbulence cannot be predicted. Hot air re-circulation will severely affect unit efficiency (EER) and can cause high pressure or fan motor temperature trips. Dunham-Bush will not be responsible for ducting fans to a higher level to alleviate the above mentioned conditions.

GUIDE SPECIFICATIONS

1.0 GENERAL

1.1 SUMMARY

Supply and commissioning of complete factory assembled air cooled screw chiller suitable for outdoor installation. The air cooled chiller shall contain rotary vertical screw compressor(s), evaporator, air cooled condenser with coil and fan, interconnecting refrigerant piping, electronic expansion valve, control panel, chilled liquid connections. The control panel shall be fully wired by the manufacturer to connect and interlock controller, starter, protection devices with electrical power and control connections. Packaged chiller shall be factory assembled, charged and run tested with a full operating refrigerant and oil charge. The refrigerant type shall be R134a and shall not have phasing out schedule.

Contractor shall furnish and install chiller as shown and scheduled on the drawings. Unit shall be installed in accordance with this specification.

1.2 QUALITY ASSURANCE

- ✿ Chiller performance shall be rated in accordance to AHRI 550/590 standard latest edition
- ✿ ASME standard B31.5 for Refrigerant piping
- ✿ Vessels shall be fabricated and pressure tested in accordance with ASME Boiler and Pressure vessel code, Section VIII, Division 1 “Unfired Pressure Vessels”
- ✿ Manufacturer shall have experience of minimum 15 years in manufacturing Air Cooled Screw Chillers in their facility
- ✿ Unit shall be manufactured in ISO9001 registered manufacturing facility.
- ✿ Unit shall be ETL listed for North America and Canada regions
- ✿ [OPTIONAL] ASHRAE Standard 15 safety code for mechanical refrigeration
- ✿ [OPTIONAL] PED certification required in Europe market place
- ✿ Factory run test: Chiller shall be pressure tested, evacuated and fully charged with refrigerant and oil. The chiller shall be run tested with water flowing through the vessels
- ✿ Manufacturer shall have a service organization with trained service personal

1.3 DESIGN BASE

The construction drawings indicate a system based on a selected manufacturer of equipment and the design data available to the Engineer during construction document preparation. Electrical services, size, configuration and space allocations are consistent with that manufacturer’s recommendations and requirements.

Other listed or approved manufacturers are encouraged to provide equipment on this project; however, it will be the Contractor and/or Supplier’s responsibility to assure the equipment is consistent with the design base. No

compensation will be approved for revisions required by the design base or other manufacturers for any different services, space, clearances, etc.

1.4 DELIVERY, STORAGE AND HANDLING

Unit shall be delivered to job site fully assembled with all interconnecting refrigerant piping and internal wiring ready for field installation and charged with refrigerant and oil by manufacturer. When delivered, machine shall be stored indoors, away from construction dirt, dust, moisture or any other hazardous material that would harm the chillers. Inspect under shipping tarps, bags, or crates to be sure there is no water collected during transit. Protective shipping covers shall be kept with the unit until machine is ready for installation.

1.5 WARRANTY

Chiller manufacturer’s warranty shall cover for 12 months from the date of start-up or 18 months from the date of shipment whichever is first. The start-up shall be carried out by a authorized service personnel and the warranty is limited to part replacement excluding labor and consumables such as refrigerant, oil & filter driers etc.

1.6 MAINTENANCE

Maintenance of the chillers will be the responsibility of the owner and performed in accordance with the manufacturer’s instructions

2.0 PRODUCTS

2.1 OPERATING REQUIREMENTS

The units will be furnished as shown on capacity schedules and drawings. Unit performance will be in accordance with AHRI Standard 550/590.

The unit shall be capable of starting up with entering fluid temperature to the cooler at 95°F [35°C].

The unit shall be capable to produce chilled fluid temperature between 40°F to 60°F [4.5°C to 15.6°C] at standard operating mode.

[OPTIONAL]:

- A. Dual Mode operation – The unit shall capable for ice thermal storage applications with supply brine temperature down to 18°F [-7.8°C].
- B. Low Temp. Operation – The unit shall capable for process cooling application with supply fluid temperature down to 18°F [-7.8°C].

The unit shall be design to operate at ambient temperature 45°F to 125°F [7°C to 52°C].

[OPTIONAL]:

- A. Low Ambient Operation (LA1) – The unit shall capable to operate with ambient temperature down to 14°F [-10°C].

GUIDE SPECIFICATIONS

B. Extra Low Ambient Operation (LA2) – The unit shall be capable to operate with ambient temperature down to -20°F [-29°C].

Unit shall be able to operate with 3-phase power supply with voltage within +/- 10% of unit rated voltage.

Control Voltage shall be 115V/1ph.

2.2 CONSTRUCTION

The unit panels, control boxes shall be constructed by heavy gauge, galvanized steel with powder coating baked finishing to pass 1000-hours salt spray test in accordance with ATSM B117 standard.

2.3 COMPRESSOR

The packaged chiller shall be furnished with direct drive, hermetic sealed, positive displacement rotary screw compressor(s), driven by a 2950 RPM-50Hz (3500 RPM-60Hz) 2 pole motor.

Each compressor shall include integral oil separation system, oil sump and oil filter. The oil differential pressure shall be controlled during operation to maintain proper oil lubrication throughout the lubrication system. An electric oil heater shall be supplied with each compressor to maintain required oil temperature during shutdown period. The heater shall be energized when the chiller is switched off.

Each compressor shall have an oil level sight glass, suction check valve, suction filter and discharge service valve. Unit shall be provided with isolation valves to allow condenser to be used as a pump down receiver.

Compressor capacity control shall be obtained by an electrically initiated, hydraulically actuated slide valve within each compressor. The bearing shall be heavy duty, anti-friction, anti-reverse tapered roller type, shall be able to carry both radial and thrust loads.

The compressor motor shall be hermetic refrigerant gas cooled, 2 pole, and squirrel cage induction type with class H insulation. Motor winding shall have thermistors embedded in the motor windings. The thermistors shall be wired to the solid state motor protection module to protect motor from overheating.

The compressor(s) shall be acoustically enclosed in a galvanized steel casings enclosure with perforated liner insulated with fiberglass for maximum sound absorption.

[OPTIONAL]:

- A. Compressor Suction Service Valve – To further isolate compressor from evaporator.
- B. Compressor Acoustic Jacket - For unit operation which require further sound reduction.
- C. Flanged Semi-Hermetic Compressor – Semi-hermetic compressor shall be provided on request.

2.4 EVAPORATOR

Evaporator vessel shall be cleanable shell and tube, flooded type. Shell shall be fabricated from rolled carbon steel sheet with fusion welded seams or carbon steel standard pipes. End plates shall be of carbon steel with precision drilling, reamed in order to

accommodate tubes. Intermediate tube support shall be in place to provide required tube support between tube sheets. Tubes shall be of copper, seamless, high efficient, internally enhanced and externally finned, mechanically expanded into fixed steel tube sheets. Tube diameter shall be ¾ inch and thickness shall be 0.025 inch. The flooded evaporator shall have a built in distributor for feeding refrigerant evenly under the tube bundle to produce a uniform boiling action and baffle plates shall be provided to ensure vapor separation.

Water box shall be removable type for tube cleaning. Water connections shall be with Victaulic grooves in compliance to ANSI / AWWAC-606. Vent and drain plugs are to be provided in water box. The shell side of the evaporator shall have pressure relief valve with provision for refrigerant venting.

Evaporator refrigerant side shall be designed and constructed in accordance with the ASME Code for Unfired Pressure Vessels. Evaporator shell side shall be designed for working pressure up to 200PSIG [13.8BAR] and undergo pneumatic pressure test at 220PSIG [15.2BAR]. Tube side shall be designed for 150PSIG [10.3BAR] working pressure and undergo hydrostatic pressure test at 195PSIG [13.4BAR].

The flooded evaporator shall have an efficient and reliable oil recovery system. The oil recovery system shall insure the evaporator is operating at peak efficiency at all times and provide optimal energy efficiency during extended periods of part load. Units without such oil recovery systems shall not be acceptable.

All low temperature surfaces shall be factory insulated with 1 inch [25mm] thick Polyethylene resin having K factor of 0.26 btu-in / hr.ft².°F.

[OPTIONAL]:

- A. Evaporator Flanged Water Connection – Flanged water connection shall be provided in lieu of Victaulic connection.
- B. Double Thick Insulation – Evaporator shall be provided with 2 inch [50mm] thick closed cell insulation for extra resistance to condensation.
- C. 250PSIG [1.7MPa] Working Pressure Vessel – Evaporator with 250PSIG working pressure on shell side shall be provided.
- D. PED Compliance – Evaporator with PED approval shall be provided for installation in European countries.

2.5 CONDENSER AND FANS

Condenser shall be Air cooled type with tube/fin coil design. The coil shall be constructed of seamless inner-grooved copper tube and die formed aluminum fins having self spacing collars in staggered configuration. Copper tubes shall be mechanically expanded into the fins.

The coil construction shall be of V configuration in order to increase heat transfer area and condenser divider baffles shall fully separate each condenser fan section to control the air flow by fan cycling and fan staging to

GUIDE SPECIFICATIONS

maintain optimum head pressure. Coil plate shall be made of galvanized steel and divider baffles shall be made of galvanized steel with powder coating.

The fan shall be direct drive propeller type, made of heavy duty alloy blades, in order to have higher resistance for dust and sand abrasion. Fan shall be protected with powder coated steel wire fan guard.

The motor shall be 3-phase, TEFC, squirrel cage induction type with IP55 enclosure and class F insulation. The motor bearing shall be permanently lubricated. Motor shall have internal thermal protection.

The fan and the motor assembly shall be rigidly secured to the casing with a heavy gauge steel powder coated fan brackets with air discharge upward.

The coils shall be pneumatic leaked and pressure tested at 450PSIG [31BAR].

The condenser shall be sized for full pump down capacity.

[OPTIONAL]:

- A. Pre-coated Aluminum fin/Copper tube coil – Copper tube/Pre-coated Aluminum fin construction shall be made of seamless inner grooved copper tubes mechanically expanded into pre-coated (hydrophilic coated) aluminum fins. The tube sheet shall be of galvanized steel and the divider baffles shall be of galvanized steel with powder coating
- B. Copper tube/Copper fin coil – Copper/Copper coil construction shall be made of seamless inner grooved copper tubes mechanically expanded into copper fins. The tube sheet shall be of galvanized steel or stainless steel and the divider baffles shall be of galvanized steel with powder coating.
- C. Post-coated Aluminum fin/Copper tube coil – Copper tube/post-coated Aluminum fin coil construction shall be made of seamless inner grooved copper tubes mechanically expanded into Aluminum fins. The tube sheet shall be of galvanized steel. The entire coil shall be coated with anti corrosive coating after the coil fabrication. The divider baffles shall be made of galvanized steel with powder coating.
- D. Protective Grille For Condenser Coil – Protective grille shall be provided to condenser coil section to prevent unauthorized access.
- E. Low Noise Operation – Low noise operation shall be provided to lower down unit operating sound level.

2.6 REFRIGERANT CIRCUIT

The refrigerant circuit shall include discharge service valves, liquid line shut off valve, oil filter, replaceable filter drier, and sight glass at liquid line. Liquid line angle valve shall be provided for refrigerant charging. Pressure relief valves shall be provided at evaporator and compressor body.

The packaged chiller shall be furnished with electronic expansion valve for precise modulation of refrigerant flow control and improve efficiency by optimizing the suction and discharge superheat. In addition, the refrigerant control system shall optimized refrigerant

liquid level in the flooded evaporator to protect the compressor from slugging liquid refrigerant. Fixed orifice control systems shall not be acceptable.

[OPTIONAL]:

- A. Heat Recovery – Factory supplied shell-and-tube heat exchanger to reclaim waste heat from the system to produce hot water up to 131°F [55°C].
- B. Hotgas Bypass – Shall be factory for operation down to approximately 10% of full load

2.7 OIL MANAGEMENT

The chiller package shall ensure proper lubrication during the operation in order to have prolonged compressor life as well as maintaining system efficiency. An efficient pressure differential lubrication system shall be provided with oil filter, sight glass, oil sump and oil sump heater. The oil heater shall be energized during the chiller switched off to prevent oil from dilution. Oil pump shall not be acceptable.

2.8 ELECTRICAL AND CONTROL PANEL

The electrical switch gears, controller, sensor transmitters and relays shall be housed in IP54 panel. The panel casing shall be of galvanized steel with powder coating baked finishing for corrosion resistance. The panel shall be divided into two separate compartments or shall have two separate panels to house power and control devices separately.

The chiller manufacturer shall provide suitable reduced inrush starter (part winding or star-delta) for the compressor motor in order to minimize the starting current. The starter shall be factory mounted, wired to the motor and controller. The starter shall be able to provide adequate starting torque and the required acceleration for the compressor during starting.

The electrical panel compartment shall include:

- A. Main incoming power terminal block suitable to receive single entry of three phase 3-wire power supply with specified voltage.
- B. Circuit breaker for each compressor
- C. Solid state / thermal compressor motor with over current protection module for each phase
- D. Solid state compressor motor overheat protection module
- E. Under/over voltage phase reversal and imbalance relay.

The compressor starter contactors and circuit breakers shall be wired securely to the main incoming terminal block. Solid state/ thermal external compressor over load protector, over heating protection modules, over/under voltage phase relay shall be interlocked with the compressor starter contactors to provide adequate protection to the compressor motor.

[OPTIONAL]:

- A. Single Power Connection Point – Single point connection point shall be provided for unit with modular design.

GUIDE SPECIFICATIONS

- B. Unit Mounted Main Disconnect Switch – Non-fused disconnect switch with external lockable handle shall be provided to isolate unit main incoming power supply for servicing.
- C. Ground Fault Interrupt (GFI) – GFI shall be provided for ground fault protection of the unit.
- D. Softstarter for compressors motor – Solid state starter comes with bypass contactor shall be offered in lieu of standard starter for better compressor starting characteristic.
- E. Ammeter / Voltmeter – Analog ammeter and voltmeter with 3-phase selector switch shall be provided for quick system voltage and current indication
- F. IP55 control panel – Option shall be offered to upgrade the standard IP54 control panel to IP55 rated.

2.9 CONTROLS

2.9.1 GENERAL

The packaged chiller shall be equipped with stand along proactive advance controller which adapts to abnormal operation conditions. The unit algorithm program and operating parameters shall be stored in flash-memory that does not require a battery back-up. Controller requires back-up battery is not acceptable.

115V power supply to the control circuit shall be provided by a factory mounted control transformer installed in the panel. External power source to the control circuit is not acceptable.

The controller shall be equipped with a user friendly back-lit 132 x 64 pixels semi-graphic display and dedicated keys that provide easy access to the unit operating parameters, control set points and alarm history. There shall be dedicated physical buttons to enable user to access information, based on security level of password. There shall be min three level of password for operator, service personnel and for the critical manufacturer settings in order to protect the chiller controller from unauthorized access.

The controller shall be provided with a set of terminals that connected to various devices such as temperature sensors, pressure transducers, current transducers, solenoid valves, compressor contactors, electronic expansion valve, control relays. The controller should be able to be configured and connected multiple units that allow sequencing control without additional hardware. The controller shall be able to carry out all program operations. It shall be able to display unit operating parameters, compressor information, alarm history and shall able to modify the parameters.

The controller shall be able to carry out self-diagnostic test on the controller and the connected devices and alarm messages shall be displayed automatically on faulty devices.

All messages shall be displayed in English language. Readings and settings displayed shall be selectable between Imperial or SI units.

Leaving chilled water temperature control shall be accomplished by entering the water temperature set point with accuracy to 0.8°F and placing the controller automatic control mode. The controller shall monitor all control functions and move the compressor slide valve to the calibrated position. The compressor loading cycle shall be programmable and shall be adjusted to the building load requirement. The loading adjustable range shall be from 0.1% to 0.4% per increment to prevent excessive demand hike at start up.

The controller shall continuously monitor evaporator leaving water temperature, rate of change of chilled water leaving temperature, evaporator and condenser pressure; compressor amp draw; and discharge refrigerant temperature.

The controller shall be capable to accept low level remote control signal. Remote Start/Stop shall be provided as standard for unit start/stop by external on/off signal.

[OPTIONAL]:

Chilled Water Temperature Reset – The controller shall be capable to accept a 0 to 5VDC chilled water temperature reset signal to reset the chilled water supply temperature setpoint, based on external demand.

Demand Limit / Current Limit – The controller shall be capable to accept a 0 to 5VDC demand limit signal to limit the compressors operating current during the unit operation.

The electrical control panel shall be wired to permit fully automatic operation during - initial start-up, normal operation, and shutdown conditions. The control system shall contain the following control, displays and safety devices:

2.9.2 AUTOMATIC CONTROLS

- ✿ Compressor motor increment contactors
- ✿ Start delay timer
- ✿ Anti-recycle timer
- ✿ Oil sump heater interlock relays
- ✿ Chilled water pump on/off control
- ✿ Programmable with Seven day operation cycle

2.9.3 MANUAL CONTROLS

- ✿ Auto/Local/Remote switch
- ✿ Control circuit stop and start switches
- ✿ Compressor enable switch

[OPTIONAL]:

Dual mode changeover switch – Digital input to changeover unit operation from chiller mode to freezing mode.

2.9.4 INDICATOR LIGHTS

- ✿ Compressor Motor high temperature
- ✿ Compressor motor overload
- ✿ System common alarm

The control system shall be provided with an anti-recycle device. The control shall limit compressor starting to a minimum of 15 minutes between starts.

GUIDE SPECIFICATIONS

2.9.5 REFRIGERANT CONTROLS

- ✿ Refrigerant flow control shall be carried out electronically by a precision electronic expansion valve
- ✿ Compressor loading and unloading solenoid valves

2.9.6 SYSTEM INFORMATION

The chiller display shall provide following operating information.

- ✿ Leaving chilled water temperature
- ✿ Entering Chilled water temperature
- ✿ Compressor discharge temperature
- ✿ Leaving chilled water temperature derivative
- ✿ Evaporator pressure
- ✿ Condenser pressure
- ✿ Ambient Temperature
- ✿ Compressor amps draw for each compressor
- ✿ Compressor elapsed run time of each compressor
- ✿ Compressor start status
- ✿ Oil level sensor status
- ✿ Water flow switch status
- ✿ External start/stop command status
- ✿ Percentage of compressor capacity
- ✿ Electronic expansion valve percentage of opening

[OPTIONAL]:

- ✿ Operating supply Voltage
- ✿ Chilled water temperature reset value
- ✿ Demand limiting value

2.9.7 SAFETY PROTECTION

- ✿ Short circuit protection.
- ✿ Compressor motor over load protection (3 phase)
- ✿ Under or over voltage and phase failure relay
- ✿ Reverse rotation
- ✿ Compressor motor overheat protection
- ✿ High discharge temperature protection
- ✿ Low oil level protection via optical sensor
- ✿ High condenser pressure
- ✿ Low evaporator pressure
- ✿ Low differential pressure
- ✿ Freeze protection (low chilled liquid leaving temperature)
- ✿ Chilled water flow loss
- ✿ Compressor run error
- ✿ Power loss
- ✿ Sensor error
- ✿ Refrigerant loss
- ✿ Low Ambient Lockoff

Controller shall be able to retain up to 99 alarm histories complete with time of failure and all critical

sensor readings. This aids service technicians in their trouble shooting task enabling downtime and nuisance trip-outs to be minimized.

2.9.8 REMOTE MONITORING (BMS INTERFACING)

The controller shall be designed to make easy on BMS interfacing by just an optional add-on communication card.

Various communication protocols as below shall be offered for user's selection.

- ✿ Modbus RTU RS485 / TCPIP
- ✿ BACnet TCPIP / MsTP / PTP
- ✿ LONworks

2.9.9 OPTIONAL ACCESSORIES

Factory shall supply below accessories for customer's field installation.

- ✿ Evaporator Water Flow Switch – Weather tight flow switch with three options for customer's selection; Flow switch with CE mark; NEMA 1 and NEMA 4 rated flow switch
- ✿ Rubber-In-Shear Isolators
- ✿ Spring Isolators

3.0 EXECUTION

3.1 INSTALLATION

Chiller shall be installed strictly according to manufacturer's recommendations as stipulated in the installation manual, drawings and tender documents. Care should be taken to provide necessary service clearance as required in the manufacturer's drawing. Install the strainers at the inlet to the evaporator to prevent debris or other particles entering to the evaporator during piping work and initial flushing the system. Required coordination to be done with the electrical contractor and the control contractors to ensure electrical supply and required communications links are established.

3.2 START-UP/COMMISSIONING

Chiller shall be commissioned by a service representative from manufacturer or by their local representative. The service personnel shall be trained and authorized by the manufacturer for start up of the supplied units. The start-up shall include briefing operators on chiller operations and maintenance as well.





Malaysia

Lot 5755-6,
Kidamai Industrial Park,
Bukit Angkat,
43000 Kajang,
Selangor, Malaysia

Tel: +603-8924 9000
Fax: +603-8739 5020

China

No. 1 Dunham-Bush Road,
Laishan District,
Yantai,
Shandong Province,
China 264003

Tel: +86-535-739 7888
Fax: +86-535-739 7999

United Kingdom

8 Downley Road,
Havant,
Hampshire,
England PO9 2JD

Tel : +44-23-9247 7700
Fax: +44-23-9245 0396

United States of America

1800 SE 38th Avenue,
Homestead,
Florida 33035
United States of America

Tel: +1(786)-800 9999
Fax: +1(786)-527 3539

United Arab Emirates

Office # 2606,
Fortune Executive Towers,
Cluster T1, Jumeirah Lake Tower
Dubai, UAE

Tel: +971-4-443 9207
Fax: +971-4-443 9208

South Africa

No. 57 Sovereign Drive
Route 21 Corporate Park
Irene, Pretoria
South Africa

Tel: +27-12-345 4202
Fax: +27-12-345 4203

India

Unit no : 804 , 8th Floor
Spaze Platinum Towers,
Sector-47, Sohna Road,
Gurgaon-122018, India

Tel: +91-124-414 4430

Indonesia

The Boulevard Office,
3F2 Jl. Fachrudin No.5,
Kp. Bali, Tanah Abang
Jakarta Pusat - 10250, Indonesia

Tel: +62-21-2123 1392

Thailand

48/39 Soi Praditmanutham 19
Praditmanutham Road,
Lat Pharo, Bangkok 10230
Thailand

Tel: +66-0-2610 3749
Fax: +66-0-2610 3601

Singapore

2 Kallang Pudding Road
#07-07 Mactech Building
Singapore 349307

Tel: +65-6842 2012
Fax: +65-6842 2013

Vietnam

10th Floor, Nam A Bank Tower,
201-203 Cach Mang Thang 8 Street,
District 3, Ho Chi Minh City,
Vietnam

Tel: +84-8-6290 3108
Fax: +84-8-6290 3109

DUNHAM-BUSH®

info@dunham-bush.com
www.dunham-bush.com



Products that perform...By people who care

Manufacturer reserves the right to change specifications without prior notice.

M-S-04102D-1021