



# HERCULES

Water Cooled Centrifugal Chillers

**DCLCD Series 50/60Hz**

Cooling Capacity: 300 to 3000 TR (1055 to 10550 kW)



# DUNHAM-BUSH®

Products that perform...By people who care

# GENERAL

From the beginning of 20<sup>th</sup> Century, DB has been providing innovative solutions for the heating, air conditioning and refrigeration needs of its customers. Today's global company has a proud heritage that began over a 100 years' ago.

Customers demand high efficiency products with exceptional value and DB's new range of DCLCD centrifugal chillers satisfy modern market requirements with outstanding energy efficiency and proven technology, designed specifically for environmentally safe refrigerants. This combination ensures the most cost-effective, reliable solution for comfort cooling and process cooling applications.

DB continues to deliver performance with reliability packaged in the most energy efficient way with the introduction of the DCLCD range of centrifugal water chillers.

The major advantages of the DCLCD:

- ✿ High reliability
- ✿ Simple operation and maintenance
- ✿ Low sound levels
- ✿ Dual Stage impeller design for outstanding performance at high lift compression
- ✿ Simplified structure and compact size
- ✿ High efficiency at a competitive market price
- ✿ Designed to use with environmentally friendly R134a refrigerant

The DCLCD range of chillers is ideal for offices, hospitals, hotels and retail stores as well as industrial applications. The chiller offers a full range of Evaporator/Condenser/Compressor combinations, permitting precise matching of the machine capacity to system requirements. With such a wide range of available combinations, DCLCD units can be configured to provide lowest first cost, lowest operating cost or choice of several criteria important for a particular application. The centrifugal chiller selection software is certified in accordance with the latest AHRI standard 550/ 590. DB Sales Engineers are available to assist in selecting the optimum machine needed to satisfy the particular project requirements.

The DCLCD centrifugal chiller from DB offers superior value and application flexibility, a wide range of options and accessories and the peace of mind that more than 100 years of industry experience is behind this product can be ideally configured to suit your project.

## TABLE OF CONTENTS

<b>GENERAL</b> .....	2	Insulation .....	7
<b>FEATURES &amp; BENEFITS</b> .....	3	Electrical And Control System .....	8
Compliances .....	3	System Protections .....	10
Computer Performance Ratings .....	3	Options & Accessories .....	11
Compressor .....	3	<b>PRODUCT SPECIFICATIONS</b> .....	13
Impeller .....	3	<b>CHILLER DIMENSIONS</b> .....	15
Evaporator And Condenser .....	3	<b>APPLICATION DATA</b> .....	15
Sub-Cooler .....	3	Location .....	15
Capacity Control & Anti-Surge .....	4	Operating Limits .....	15
Environmental Friendly Refrigerant .....	4	Sound And Vibration .....	15
Factory Testing .....	4	Water Quality .....	15
Intelligent Control System .....	4	Evaporator Fluid Circuit .....	16
<b>CHILLER COMPONENTS</b> .....	4	Condenser Fluid Circuit .....	16
<b>WORKING PRINCIPLE AND STRUCTURE</b> .....	5	Vent And Drain Connections .....	16
Refrigeration Cycle .....	5	Refrigerant Safety Valve / Pressure Relief Valve (PRV) .....	16
Variable Speed Operation .....	6	<b>GUIDE SPECIFICATIONS</b> .....	18
IEEE Standard 519 .....	6	Scope .....	18
Oil Lubrication And Cooling System .....	6	Execution .....	23
Motor Refrigerant-Cooled System .....	7		

## NOMENCLATURE

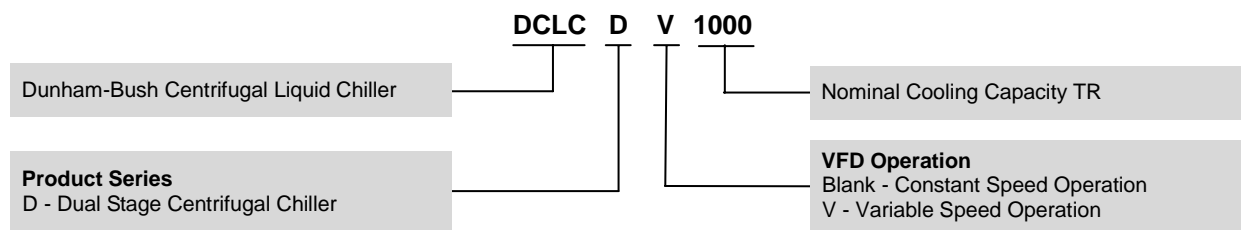

# FEATURES & BENEFITS

## COMPLIANCES

- ✦ Unit design to meets/ exceeds AHSRAE 90.1 requirements
- ✦ Performance are certified in accordance with AHRI Standard 550/590
- ✦ Refrigerant safety of DCLCD series is designed in accordance with ASHRAE Standard 15

## COMPUTER PERFORMANCE RATINGS

The vast number of combinations of heat exchangers, compressors and motors make it impractical to publish tabular ratings for each combination. A chiller may be custom matched to certain building requirements by your Dunham-Bush Sales Representatives utilizing the Computer Selection Program. Data which can be provided to you will include:

- ✦ Chiller Capacity
- ✦ kW Input
- ✦ Evaporator and Condenser Fluid Temperature
- ✦ Evaporator and Condenser Pressure Drop
- ✦ Evaporator and Condenser Tube Water Velocities
- ✦ Electrical Data
- ✦ Part-Load Performance

Contact our local Dunham-Bush Sales Representative to discuss what Custom Solutions Dunham-Bush can offer to solve your chiller selection questions.

## COMPRESSOR

- ✦ Semi-hermetic compressor for reliable operation; compressor and motor are direct gear driven. Shaft alignment, refrigerant and oil leaking at shaft seals are not applicable with this design
- ✦ Refrigerant cooled motor is hermetically sealed in compressor; motor heat generated is concealed in refrigerant system; no motor heat is rejected into chiller plantroom
- ✦ Motor shaft is supported with Babbitt bearings to reduce friction losses. High speed impeller shaft is supported by thrust bearings for reliable and efficient operation
- ✦ Built-in emergency oil reservoir to ensure continuous oil supply for compressor safe operation at coast-down period in the event of power interruption
- ✦ Built-in oil pump (gear type) reduces leaking possibility, improve operation reliability
- ✦ Built-in oil heater to maintain the oil at 100~120°F [40~50°C] even when the compressor is shut down. This prevents oil dilution, which may causes a decrease in viscosity and hence change lubrication properties

## IMPELLER

- ✦ The impeller is precision cast from special super high density aluminum alloy cast using the Integer

mold technique, resulting in light weight and high anti-corrosion ability

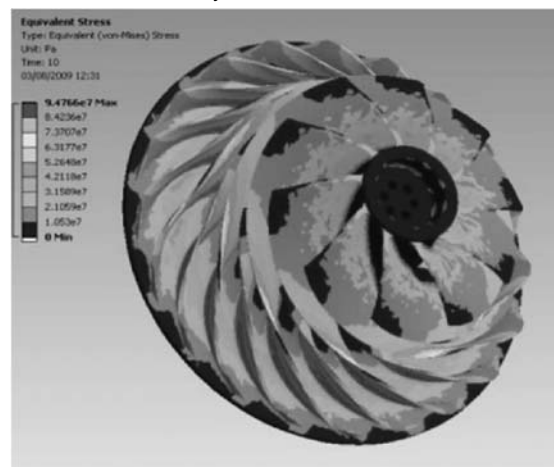

- ✦ Each impeller has succeeded in stringent balancing test and over-speed test up to 125% of rated value; to ensure stable and reliability operation
- ✦ Impellers design are aerodynamically contoured with CFD software to improve compressor full load and part load operating efficiency. Compressor efficiency is improved by 5~7%, with improve sound level, as well as anti-surge capability

## EVAPORATOR AND CONDENSER

- ✦ The vessels are designed in accordance with ASME Boiler and Pressure Vessel Code
- ✦ Refrigerant side design pressure of 200PSIG [13.8BAR]; water side design pressure of 150PSIG [10.3BAR]
- ✦ Pressure test up to 220PSIG [15.2BAR] for refrigerant side; and 195PSIG [13.4BAR] for water side
- ✦ Waterboxes are fabricated using nozzle-in-head arrangement and are supplied with vent and drain connections on the dome head
- ✦ Copper tubes with enhanced profile and grooves for best heat transfer efficiency
- ✦ Intermediate tube support sheets are provided in all heat exchangers to prevent tube sagging and vibration, which could otherwise result in premature failure
- ✦ 1, 2 or 3-passes to suite the design requirements.
- ✦ Victaulic groove water connection comply with ANSI/AWWA C-606. Flanged water connection is available on request
- ✦ Condenser is designed with full pumpdown capacity

## SUB-COOLER

- ✦ The sub-cooler is located in the bottom of the condenser
- ✦ It increases the overall refrigeration effect of the chiller by sub-cooling the condensed liquid refrigerant which results in a combination of increased cooling capacity and reduced compressor power consumption

# FEATURES & BENEFITS

## CAPACITY CONTROL & ANTI-SURGE

- ✿ Capacity control with inlet guide vane visualized precise control and energy saving operation, with enhanced anti-surge capability, permits stable operation at low load condition
- ✿ The guide vanes are connected with aircraft- quality cable and controlled by a precise electronic actuator
- ✿ Models with VFD (Variable Frequency Drive) gains further energy saving with VFD unloading during partial load operation

## ENVIRONMENTAL FRIENDLY REFRIGERANT

- ✿ Use environmental friendly HFC-134a refrigerant, with **ZERO** ODP (Ozone Depletion Potential)
- ✿ Non-toxide refrigerant with no phasing out date set by Montreal Protocol
- ✿ Positive pressure operations eliminates need of purging system, which cause additional energy to unit operation

## FACTORY TESTING

- ✿ The chillers are thoroughly run tested at the factory prior to shipment
- ✿ This ensured proper operation of all components in the system, including compression, power transmission, vibration & sound, oil lubrication system, and electrical & control system



## INTELLIGENT CONTROL SYSTEM

- ✿ The chillers are equipped with **Vision** control system. The state-of-art controller which specifically designed to operate DCLCD at optimum efficiency with proactive control logics
- ✿ 10.1 inch touch screen color display panel is furnished for user friendly operation

Intelligent adaptive liquid line modulating valve control, adaptive inlet guide vane and variable frequency drive surge control line, adaptive compressor capacity control, unique alarm, flexibility settings on high level signal and etc

# CHILLER COMPONENTS

## DCLCD Series (Dual Stage Centrifugal Chillers)

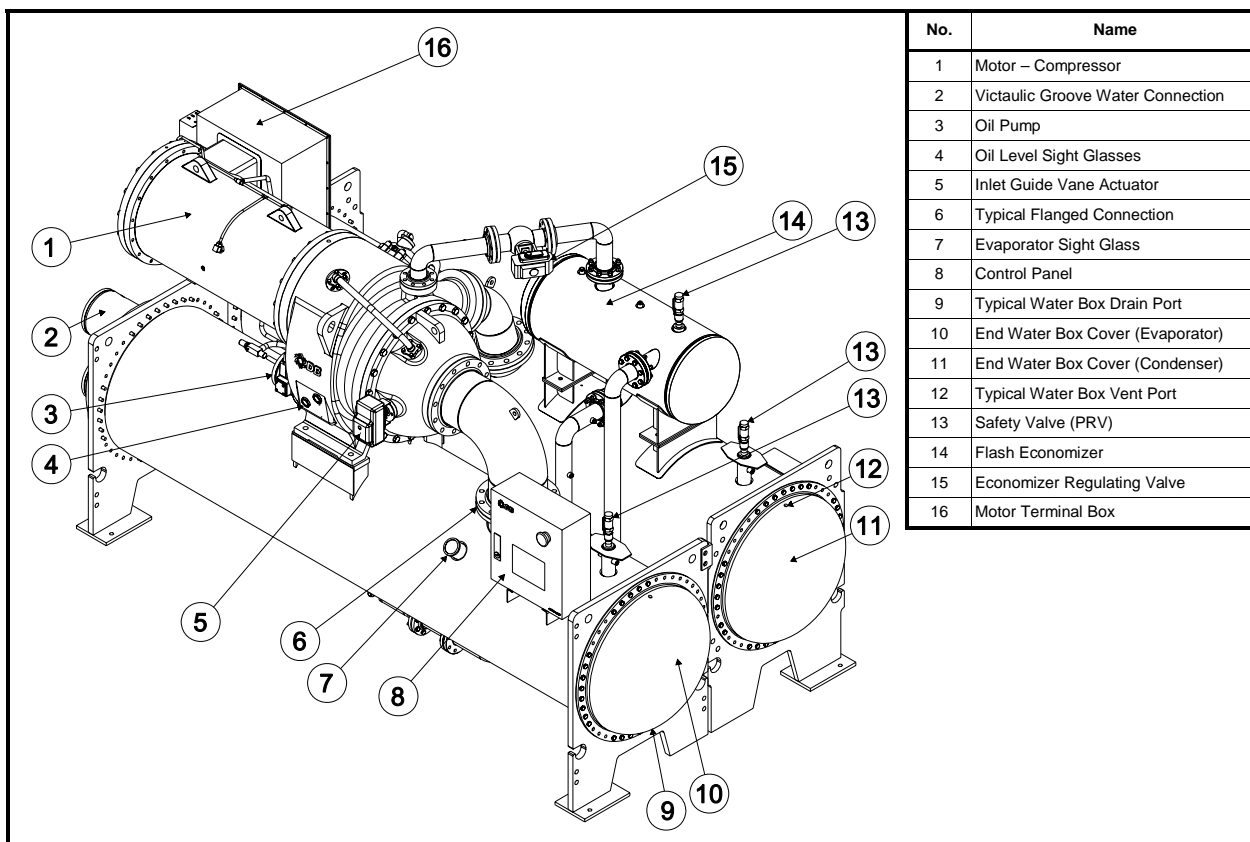

# WORKING PRINCIPLE AND STRUCTURE

## REFRIGERATION CYCLE

The compressor on a centrifugal chiller utilizes the Vapour Compression cycle in much the same way as any positive displacement compressor. The Vapour compression cycle uses a medium such as refrigerant to absorb heat at one part of the cycle and reject that heat at a different part of the cycle. The centrifugal compressor is a dynamic machine which raises the pressure and temperature of the circulating refrigerant by imparting velocity or dynamic energy through an electric motor driven impeller discharging into a volute to convert this velocity energy to pressure energy. As with all vapour compression systems, there are four major components: compressor, condenser, expansion device and evaporator. The evaporator absorbs heat from its surrounding and the condenser rejects the heat collected plus any system losses to its surroundings. The cycle will continue to operate all the time the compressor is operating and a system load exists.

The following is the principle in details:

### Compressor:

The refrigerant vapour enters the compressor in a low pressure, low temperature but superheated state. The compression process increases the pressure and the temperature and the now high pressure, high temperature superheated gas is discharged into a condenser, a heat exchanger where due to its high temperature the refrigerant can be condensed using cooling tower water or ambient air.

### Condenser:

The high pressure hot vapour is condensed into a high pressure hot liquid, or saturated liquid at its pressure corresponds to its condensing temperature. This high pressure liquid refrigerant discharges from the bottom of the condenser and is passed through an expansion valve or some other restrictive device.

### Expansion device:

The downstream side of this expansion device is exposed to the low pressure part of the system which causes the refrigerant to expand rapidly as it passes through the device, as it expands; adiabatic cooling of the gas/liquid mixture occurs at this point where it then becomes colder than the water (or other liquid to be cooled) in the evaporator.

### Evaporator:

This is a second heat exchanger where the medium (water) ultimately to be cooled by this process, the 'chilled water', is circulated on one side and the cold refrigerant mixture is circulated through the other side where it absorbs heat, thereby cooling down the chilled water. Cooling the chilled water is the fundamental purpose of the equipment. The refrigerant then continues to circulate in the system and after going through the compression process again the heat absorbed will be rejected by the condenser to the tower water or ambient air.

The cooling capacity of the system is directly proportional to refrigerant gas flow through the compressor. An adjustable guide vane regulating device can be installed at the inlet of centrifugal compressors to control the suction flow of compressor, matching the system cooling capacity to that of the building cooling load in a regulated and step less manner across a defined range.

### Dual stage impellers with economizer:

Liquid refrigerant from condenser flows through first throttling device and then flow into the economizer instead of flowing directly to the evaporator. Vapor refrigerant is separated from liquid refrigerant in the economizer. Flash vapor refrigerant exits economizer, flows and enters compressor at second stage of the compression; while remaining liquid refrigerant is further subcooled, flows through second throttling device and then flows in to evaporator. Two benefits as below are visualized by refrigeration effect with dual stage compression, which contribute to the energy saving operation of DCLCD chillers.

- Power saving operation as flash vapor refrigerant need to pass through only half of the compression cycle to reach the condenser pressure
- Further subcooled liquid refrigerant able to absorb more heat in the evaporator which benefits the cooling cycle

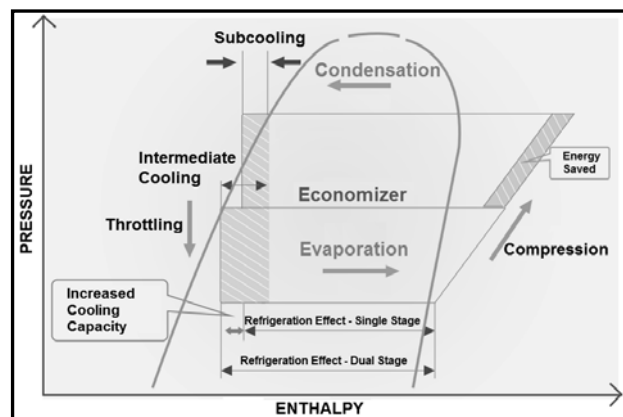
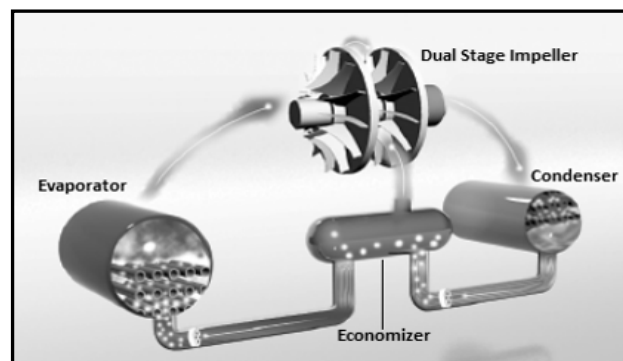

Besides energy saving operations, DCLCD also visualized stable operation in high lift conditions, as well as better resistance to surging.

# WORKING PRINCIPLE AND STRUCTURE

## VARIABLE SPEED OPERATION (DCLCDV Series)

With increasing demand on high efficiency chillers and energy saving operation, Variable Speed Drive (VSD) is coupled with centrifugal compressor to extend potential of energy saving in the chiller operation. DCLCDV chillers are equipped with inverter duty compressor motor, and remote mounted floor standing VSD panel.

DCLCDV chillers with variable speed operation visualized outstanding part load efficiency, thanks to capability to unload chiller capacity by reducing the motor speed. During partial load operation with reduced compressor lift, VSD slows down compressor motor speed to reduce impeller tip speed, to retain just sufficient tip speed to meet the discharge pressure requirement. This generates great energy saving as compared to capacity unloading by inlet guide vane of the compressor.

In actual operations where the compressor lift reduction is not substantial, unit capacity control is done by combination actions of VSD and inlet guide vane. VSD will slow down the motor speed as much as possible to retain sufficient tip speed, while inlet guide vane will do the remaining capacity reduction. This advanced control provides optimized performance with stable operation under all operating conditions.

Below graph shows typical performance comparison of DCLCD chiller versus DCLCDV chiller, and illustrate the potential savings with variable speed operation at AHRI part load operating conditions.

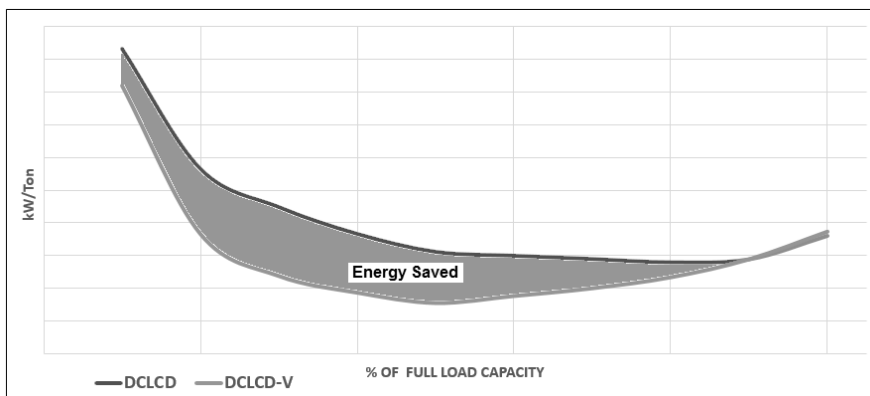

Besides benefits on energy saving as described above, VSD chillers enjoy below benefits too:-

- No inrush current – Starting current of the compressor motor is **MUCH LESS THAN** motor FLA (Full Load Amps)
- High power factor – Capability to achieve  $\geq 0.95$  power factor at entire load range with optional low harmonic drive

With the above features, sizing and selection of transformers, generators, and switchgears can be optimized. Capacitor bank for displacement power factor correction can be omitted.

## IEEE STANDARD 519

### IEEE Standard 519 – “IEEE Recommended Practices and Requirements for Harmonic Control in Electrical Power Systems”

recommends harmonic distortion limits for power utilities, as well as the customer. IEEE 519 recommends limits on Total Demand Distortion (TDD) at the Point of Common Coupling (PCC).

TDD, Total Demand Distortion is defined as “harmonic current distortion in % of maximum demand load current”.

While PCC, Point of Common Coupling is defined as the point where the building mains is connected to the public power grid.

Thus, IEEE 519 does not specify requirements for internal electrical loads, or any points in the building facility. To comply with the TDD limits as stated in IEEE 519, a power-distribution system analysis on the building’s electrical system design shall be conducted to determine degree of harmonics attenuation required.

## OIL LUBRICATION AND COOLING SYSTEM

The compressor motor assembly is internally lubricated by an oil system driven by a motor independent to that of the main compressor. The system delivers filtered oil to the compressor and motor bearings at the required temperature and pressure; the drive gears operate in a controlled lubricant mist atmosphere that efficiently cools and lubricates them.

The temperature of the lubricating oil is maintained between 95 to 130°F [35 to 55°C], by passing it through a refrigerant cooled plate heat exchanger mounted on the compressor. Refrigerant cooled oil cooler benefits the owner by eliminating the requirement for field water piping and the associated installation expenses.

To minimize the quantity of lubricating oil entering and

mixing with the refrigerant, comb (labyrinth) seals are installed at inner side of motor bearings at both ends.

Lubricant from the pump is supplied to the compressor through 10 micron oil filter(s) internal to the compressor. An external oil filter is also supplied. The external oil filter is replaceable oil filter which contained in a flanged housing providing easy and convenient access for normal inspection and maintenance of the filter

The control system will not allow the compressor to start until proper oil pressure, 18~25PSID (1.24~1.72BAR), and the proper temperature is established. It also ensures the oil pump to operate after compressor shutdown to provide lubrication during coast-down.

# WORKING PRINCIPLE AND STRUCTURE

## MOTOR REFRIGERANT-COOLED SYSTEM

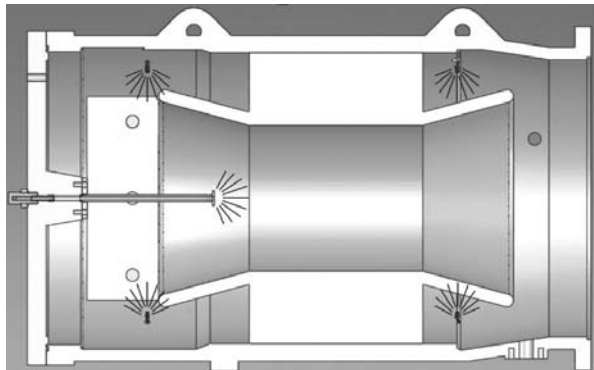

The DCLCD compressor motor is cooled by an efficient refrigerant spray cooling system. Refrigerant spray cooling method is more efficient than other methods.

The motor and the lubricating oil are cooled by liquid refrigerant taken from the bottom of the condenser vessel. Flow of refrigerant is maintained by the pressure difference during compressor operation. After the refrigerant passes through a control valve and filter, it is distributed by the motor cooling system.

The refrigerant flows through an orifice into the motor housing. Once past the orifice, the refrigerant is directed over the motor by a spray nozzle. The refrigerant collects in the bottom of the motor casing

and is then drained back to the evaporator through the motor refrigerant drain line.

The motor is protected by the temperature sensors imbedded in the stator windings. If the temperature rises above the safety limit 230°F [110°C], the compressor will shut down automatically.

## INSULATION

Factory insulation on DCLCD chillers with 1 inch [25mm] closed cell insulation are standard supply. The factory insulation for the DCLCD includes the following areas:

- ✿ The evaporator shell and tube sheets
- ✿ Suction line up to the compressor suction housing
- ✿ Compressor motor and motor cooling return lines
- ✿ Several small oil cooling and oil return system lines, the liquid line
- ✿ Economizer

For unit installation at high humidity job site may require **Double Thick Insulation** option to prevent possibility of condensation.

**Note:** In the case that factory insulation is excluded and unit insulation to be carry out at job site. Thermal insulation shall be fitted in a way that will not interfere with the normal operation of the unit and that will also allow removal of the water boxes to enable cleaning of the heat exchanger tubes. Access to fasteners and nameplate shall be maintained at all times.

## Typical Insulated Area By Factory Insulation

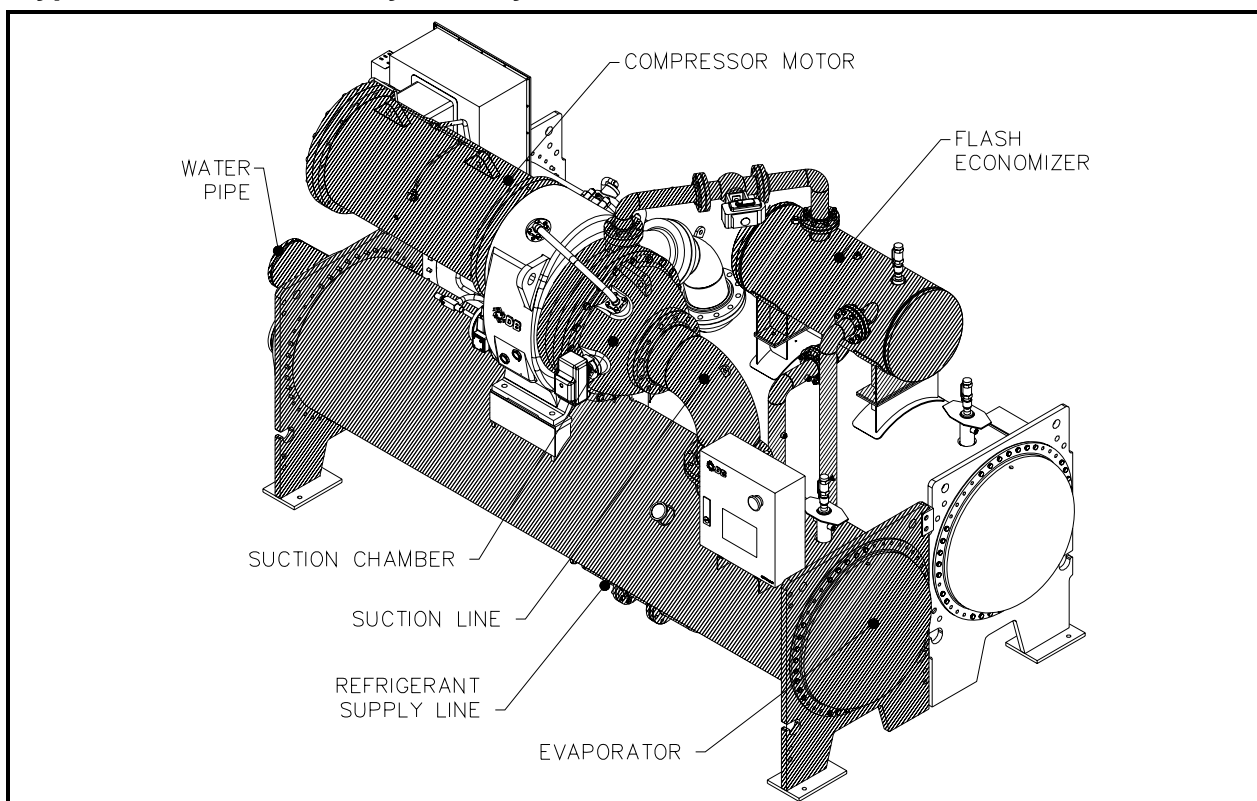

# WORKING PRINCIPLE AND STRUCTURE

## ELECTRICAL AND CONTROL SYSTEM

### Main Power Supply Voltage and Starter Cabinet

Various main power supply voltages for compressor motor are available in all DCLCD series, as below.

#### Low Voltage (LV)

50Hz – 380V; 400V; 415V

60Hz – 200V; 230V; 380V; 400V; 460V; 575V

#### Medium Voltage (MV)

50Hz – 3000V; 3300V; 6000V; 6600V; 10000V; 11000V

60Hz – Consult factory

Optional floor Standing NEMA 1 starter cabinet can be supplied and shipped loose for site installation.

Refer to **Options and Accessories** for various type of starter cabinet offered by DB.

### Control Power Supply and Unit Electrical Enclosure

The DCLCD unit electrical panel is designed to contain oil pump starter together with the control system in single enclosure for the ease of installation. The enclosure is NEMA 1 rated for indoor installation.

Design with single power termination point (3-phase power supply) to provide power supply for oil pump, oil heater(s) and controls. Step down transformer is built-in to step down the main voltage to the required control voltage.

Power consumption of oil heater and oil pump are as below.

Item	Input Power kW
Oil Heater	1.0
Oil Pump	1.5

The 3-phase power supply to the control panel can be any of below.

Frequency of Power Supply	Voltage of Power Supply
50Hz	380V; 400V; 415V
60Hz	208V; 230V; 380V; 460V; 575V

### Vision Control System

The DCLCD series adopts a revolutionary **Vision** controller that equipped with a user friendly DBGX display panel. The display has specifications of 10.1 inch TFT display, 1024x600 resolution with 64k colors, and has LED backlight touch screen graphics. The DBGX terminal allows carrying our all-program operations. The user terminal allows displaying the unit working conditions, compressor run times, alarm history at any times, and modifying the parameters. The terminal also comes with a *self-test* feature for the controller on system start-up. Multiple messages will be displayed by automatically scrolling from each message to the next. All of these messages are spelled

out in English (other language optional) language on the LED screen.

**Vision** controller is able to log data from the centrifugal compressor up to 3 weeks with a 1-minute log interval. The data is then stored in the controller and allowed to be extracted at any time. This feature allows the user to view the compressor status and allows easier diagnosing of issues for the service technician.

**Vision** controller in the DCLCD chiller is a modular controller which contains a port that is equipable with various communication cards. This user friendly design allows Building Management System (BMS) to interface directly with the chiller via either of Modbus, BACnet MS/TP communication protocol, BACnet TCP/IP communication protocol, or LonWorks. This feature provides owners with a simple and inexpensive method of investigating potential problems in a quick and efficient manner.

**Vision** controller is equipped with a 10.1 inch DBGX10 touch screen graphical display. This user friendly graphical interface provides the following:

- ✿ Adjustment of chiller operation set point
- ✿ Real time inspection and supervising of chiller operation status
- ✿ Real time failure inspection
- ✿ Historical alarm logging
- ✿ Total chiller running time
- ✿ Elapsed compressor run time
- ✿ Compressor Variable Frequency Drive (only applicable to DCLCDV models)

The screen displays parameters of chiller operation and to achieve constant monitoring. The start-stop and automatic control procedures can be adjusted, user can access the unit status and reliable start, stop, adjustable operation automatically through simply click on the button.

Below analog readouts are available on the display panel.

- ✿ Leaving chilled water temperature
- ✿ Entering chilled water temperature
- ✿ Leaving condenser water temperature
- ✿ Entering condenser water temperature
- ✿ Cooler and condenser pressure
- ✿ Cooler and condensation saturation temperature
- ✿ Motor temperature
- ✿ Motor bearing temperature
- ✿ Discharge temperature
- ✿ Discharge superheat
- ✿ Condenser and cooler approach temperature
- ✿ Condenser and cooler superheat
- ✿ Running amps
- ✿ Percentage of the full load Amps
- ✿ Inlet guide vane open degree
- ✿ Liquid modulating valve opening degree
- ✿ Vapor injection opening degree
- ✿ Hot gas bypass opening degree
- ✿ Water temperature set value
- ✿ Oil sump temperature
- ✿ Oil sump pressure
- ✿ Oil sump superheat
- ✿ Oil pressure difference



# WORKING PRINCIPLE AND STRUCTURE

- ✿ Cooler and condenser pressure ratio
- ✿ Refrigerant leak (optional)
- ✿ Suction temperature (optional)
- ✿ Liquid line temperature (optional)
- ✿ Liquid line pressure (optional)
- ✿ Subcooling temperature (optional)
- ✿ System voltage monitoring (optional)

Below digital readouts are available on the display panel.

- ✿ Compressor run/stop status
- ✿ Compressor alarm status
- ✿ Oil pump alarm status
- ✿ Oil pump status
- ✿ Oil heater status
- ✿ Vapor injection open/close status
- ✿ Inlet guide vane open/close status
- ✿ Hot gas bypass open/close status
- ✿ External stop/start command status
- ✿ Chilled water pump status
- ✿ Condenser water pump status
- ✿ Chilled water flow
- ✿ Condenser water flow
- ✿ Cooling tower

Below are the user accessible setpoints available on the display panel

- ✿ Leaving chilled water temperature setpoint
- ✿ Leaving chilled water temperature control band
- ✿ Unit measurement (SI unit or Imperial)
- ✿ Compressor on/off switch
- ✿ Weekly operating schedule
- ✿ Chilled water temperature reset (optional)
- ✿ Demand limiting(optional)

## Vision Master-Slave Control Sequence (MSS)

The optional Master-Slave Sequencing Control is used

to sequence multiple chillers in one installation according to the building load demand. It also controls the dedicated chilled water pump or motorized valve.

**Vision** Controller offers this feature with minimized field wiring cost compare to conventional method that involves lots of hardware cost. It is carried out this control function via the advanced DBLAN communication bus to implement the network management for multiple chillers lead/lag communication, sequencing and monitoring.

- ✿ Each chiller has a stand-alone **Vision** controller and dedicated display (DBGX10) via port J23
- ✿ Each chiller's **Vision** will be connected to DBLAN network through port J11 using twisted pair shielded cable
- ✿ The **MSS** chiller lead/lag selection can be determined by
  - Manual lead/lag setpoint
  - Schedule and holiday setup
  - Alarm conditions
- ✿ The lead/lag selection determine the chiller operation sequence as follows. The following is an example of three chillers network with two units on-duty and one unit on standby.

Lead chiller selection	Chiller operation sequence
1	1 & 2 on duty, 3 standby
2	2 & 3, 1 standby
3	1 & 3 on duty, 2 standby

- ✿ If the lead/lag selection is changed over to a different chiller, the sequence of operation will be rotated
- ✿ Each chiller will use a network address setpoint to determine individual chiller network address
- ✿ Master-slave control can be extended up to maximum six (6) chillers in the DBLAN network.

## The Unit Operating Parameters

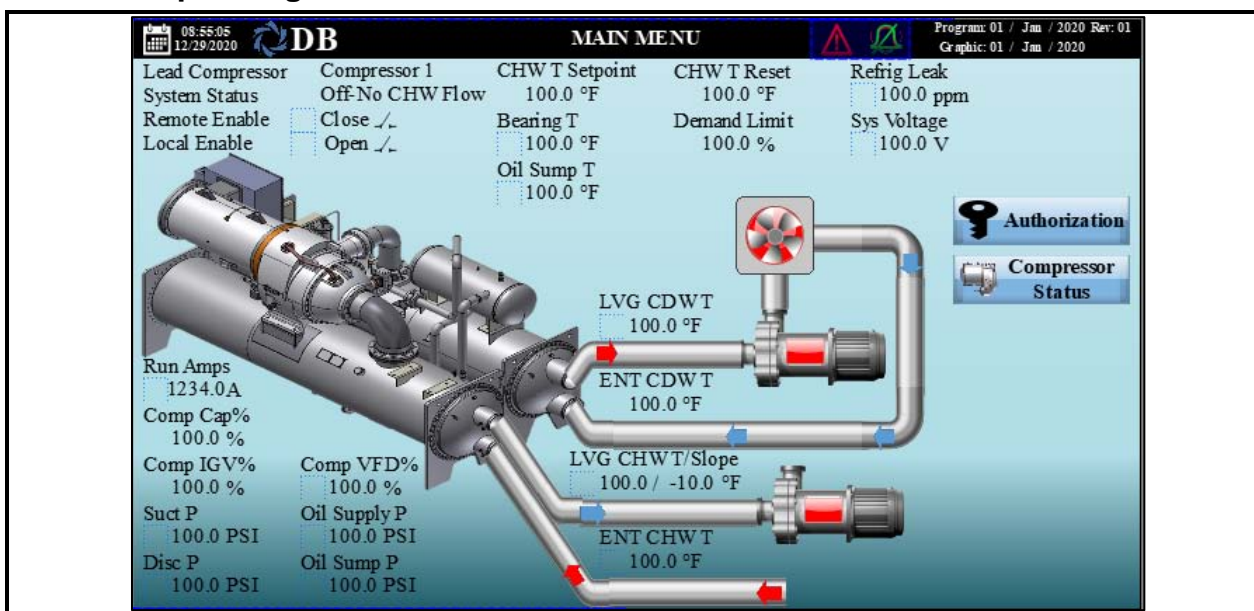

# WORKING PRINCIPLE AND STRUCTURE

## The Compressor Operating Parameters

Unit Target Freq		LVG CHW T		LVG CHW T Slope		Comp Condition	
15 sec	100.0 °F	100.0 °F	-10.0 °F	Surging	Comp Status	On - Line Valve Open	
Unit Target IGV	100.0 %	Comp Target IGV	100.0 %	Comp IGV%	No of Lockout	1 / 6	
100.0 %	100.0 %	Comp Target VFD	100.0 %	Comp VFD%	No of Surge	1 / 4	
100.0 %	100.0 %	Full Load Amps	Run Amps	Run Amps Slope	Liq Line Status	Open-Normal	
100.0 A	1234.0A	100.0 A	100.0 A	100.0 A	Starter Status	Close /_	
Comp Cap%	100.0 %	Comp Cap% Slope	Comp Run Speed	100 rpm	Starter Alarm	Open /_	
100.0 %	100.0 %	100.0 %	100 rpm	Oil Pump Alarm	Oil Pump Alarm	Open /_	
Suct P	Sat Suct T	Suct P Slope					
100.0 PSI	100.0 °F	-10.0 PSI					
Disc P	Sat Disc T	P Ratio					
100.0 PSI	100.0 °F	3.21					
Oil Supply P	Oil Sump P	Sat Oil Sump T					
100.0 PSI	100.0 PSI	100.0 °F					
Oil Diff P	Oil Sump T	Oil Sump SH					
100.0 PSI	100.0 °F	100.0 °F					
Comp On	Oil Pump	Vap Inj Open					
IGV Open	Oil Heater	Vap Inj Close					
IGV Close		HGBP Open					
		HGBP Close					

Running Hour  
More Info

## The Compressor Operating Parameters (more info)

Unit Target Freq		LVG CHW T		LVG CHW T Slope		ENT CHW T		LVG CDW T		ENT CDW T	
15 sec	100.0 °F	100.0 °F	-10.0 °F	100.0 °F	100.0 °F	100.0 °F	100.0 °F	100.0 °F	100.0 °F	100.0 °F	
Unit Target IGV	100.0 %	Comp Target IGV	100.0 %	Comp IGV%	Cool App Target	Cool App	Cool App Slope	100.0 °F	100.0 °F	100.0 °F	
100.0 %	100.0 %	Comp Target VFD	100.0 %	Comp VFD%	Liq Line Freq	Liq Line Output%	Liq Line Slope%	100.0 %	100.0 %	100.0 %	
100.0 %	100.0 %	100.0 %	100.0 %	100.0 %	15 sec	100.0 %	100.0 %	100.0 %	100.0 %	100.0 %	
Full Load Amps	Run Amps	Run Amps Slope	Vap Inj Output%	HGBP Output%	100.0 %	100.0 %					
100.0 A	1234.0A	100.0 A	100.0 %	100.0 %	100.0 %	100.0 %					
Comp Cap%	Comp Cap% Slope	Comp Run Speed	Motor T	100.0 °F							
100.0 %	100.0 %	100 rpm	Suct T	100.0 °F							
Suct P	Sat Suct T	Suct P Slope	Suct SH	100.0 °F							
100.0 PSI	100.0 °F	-10.0 PSI	100.0 °F	100.0 °F							
Disc P	Sat Disc T	P Ratio	Disc T	100.0 °F							
100.0 PSI	100.0 °F	3.21	Disc SH	100.0 °F							
Oil Supply P	Oil Sump P	Sat Oil Sump T	Diffuser Target%	Diffuser Opening%							
100.0 PSI	100.0 PSI	100.0 °F	100.0 %	100.0 %							
Oil Diff P	Oil Sump T	Oil Sump SH	HGBP Opening%	100.0 %							
100.0 PSI	100.0 °F	100.0 °F	100.0 %	100.0 %							
Comp On	Oil Pump	Vap Inj Open									
IGV Open	Oil Heater	Vap Inj Close									
IGV Close		HGBP Open									
		HGBP Close									

More Info

## SYSTEM PROTECTIONS

The chiller controller uses proportional integral-derivative (PID) control for all limits. This removes oscillation above and below setpoints and extends the capabilities of the chiller.

Some of the standard protection features of the chiller controller are described in this section. There are additional protection features not listed here.

**Low Pressure Safety:** This function protects the unit from operating at abnormally low evaporator pressure. When the evaporator pressure of a refrigeration circuit drops below the Low-Pressure Cut-off safety setpoint, the controller will shut down all compressors in that

refrigerant circuit and turn on the alarm light.

**High Pressure Safety:** This function protects the unit from operating at abnormally high condensing pressure. When the condensing pressure of a refrigeration circuit exceeded the High-Pressure Cut-off safety setpoint, the controller will shut down all compressors in that refrigerant circuit and turn on the alarm light.

**Oil Supply-Oil Sump Low Differential Pressure Alarm:** If the difference between the Oil Supply Pressure and the Oil Sump Pressure is less than 20 Psi (1.4 bar), an alarm will pop out to prevent the compressor from running.

# WORKING PRINCIPLE AND STRUCTURE

---

**High Discharge Temperature Alarm:** If the discharge temperature sensor measures a value higher than 160°F or 70°C (setpoint changeable under Safety Cutout Setup in Factory Settings), the controller will shut down the unit and turn on the alarm light.

**High Oil Sump Temperature Alarm:** If the Oil Sump Temperature measures a value above 160°F or 70°C, the controller will shut down the unit and turn on the alarm light.

**High Bearing Temperature Alarm:** If the Motor Bearing Temp sensor measures a value more than 167°F or 75°C, the controller will shutdown the unit and turn on the alarm light.

**Evaporator Freeze Safety:** If the leaving chilled water temperature drops below the freeze setpoint, the controller will shut down the unit and turn on the alarm light.

**Unit Voltage Alarm (optional):** If the voltage transducer sensor measures a value that falls above an upper limit value or falls below a lower limit value, the controller will shut down the unit and trip the alarm light.

**Sensor Failure Alarm:** If the controller measures an analogue sensor (temperature, pressure, or Amp sensor.) with the reading is beyond its measuring range, the associated compressors or system are shutdown.

**Compressor No-Stop Alarm:** If the controller turns off a compressor, but the compressor's starter status does not turn off or detects running amps, all compressors will be turned off and alarm light is turned on.

In the case the system detects running amps being used to power the compressor, the controller will enter a forced run mode where the following units will run:

- a. Compressor
- b. Chilled Water Pump
- c. Condensed Water Pump
- d. IGV (open at minimum)
- e. Liquid Line Valve (normal operation)
- f. HGBP (normal operation)

The purpose of this feature is to prevent the compressor from burning by allowing the entire system to run along with the compressor until the alarm panel shows the name of the alarm.

**Compressor No Run Alarm:** When the controller has started a compressor but did not received feedback on compressor operating current, alarm will be triggered and alarm light will turn on.

**Compressor Starter Alarm:** When the controller starts a compressor but did not received feedback on compressor's starter status, alarm will be triggered and alarm light will turn on

**Compressor Oil Pump Alarm:** When the controller receives a feedback of oil pump overload status, alarm will be triggered and alarm light will turn on.

**No Chilled Water Flow Alarm:** This alarm is activated when chilled water flow switch status is opened when compressor is running. The unit will be stopped and alarm light is turn on.

**No Condensed Water Flow Alarm:** This alarm is activated when chilled water flow switch status is

opened when compressor is running. The unit will be stopped and alarm light is turn on

**High Compressor Motor Temperature Protection:** Motor winding temperature sensors are furnished at each compressor which will trips the compressor the sensor detects the motor temperature exceed 180°F (82°C)

**Volt-Phase Control Relay (PCR):** The PCR protects the unit from the following electric supply malfunctions: under or over-voltage, phase reversal, phase imbalance and phase loss. If the PCR trips, control circuit will be de-energized and the unit will be shut down. PCR is auto-reset when power supply has back to pre-set range.

**Surge Trip Protection:** This feature protects the unit from surges by opening a hot gas bypass valve to return discharge vapor into the compressor inlet. The surge protection logic will trigger as soon as it detects a fluctuation in current difference around  $\pm 8\%$  of the Full Load Amp (FLA) or  $\pm 7$  PSI ( $\pm 0.48$  bar) in the last 5 seconds. When the current reading fluctuates above and below 8% or vice versa, a counter will record the trips.

## OPTIONS & ACCESSORIES

### Starter Panel

The factory supplied main motor starter panel are rated with NEMA-1 protection and includes below:

- ⚙ Main incoming power terminal for wires termination
- ⚙ Circuit breaker for the compressor
- ⚙ Compressor motor over current protection module
- ⚙ Compressor motor overheat protection module
- ⚙ Main power supply monitoring module to give protection on:
  - Under or over voltage
  - Phase reversal
  - Phase loss
  - Phase imbalance
- ⚙ (Optional) Ground fault interrupter

**Direct-On-Line (DOL) Starter** – DOL starter is full voltage starter with simplest design and lowest cost. Full starting torque is applied to motor during start-up, thus, starting current is equivalent to motor LRA (lock rotor amps), in another words, about 7 times of rated full load current (FLA). DOL starter is recommended for MV applications only and subject to local rules, regulation and authorities' approval.

**Star-Delta Starter** – Star-Delta starter is a reduced voltage starter where the starting voltage is reduced to 1/3 of full voltage start. Thus, starting torque applied to the motor is 1/3 of full voltage starting torque, resulting 2/3 decrement in starting current as compared to DOL starter. Generally, the starting current is about 2~2.5 times of rated FLA. Star-Delta starter with just 1/3 of full load torque is good enough to start the centrifugal compressor as centrifugal compressor is always started at "No Load" condition with inlet guide vane fully closed.

# WORKING PRINCIPLE AND STRUCTURE

---

**Softstarter (Solid State Starter)** – Softstarter, or solid state starter is an electronic controlled starter with controllable starting characteristic. Softstarter uses SCRs (silicon Controlled Rectifier) to control current flow to the motor during start-up, thus, the motor starting current can be controlled. Maximum starting current by softstarter can be preset, and usually is about 3~3.5 times of rated FLA. SCRs or softstarter will be bypass after motor has reached rated motor rpm to minimize heat loss generated by softstarter, as well as to extend the life span of the softstarter.

**VSD (Variable Speed Drive)** – VSD is motor controller which appear to be best motor starter for now. Besides enjoying no inrush motor startup by VSD starter, part load performance of DCLCD chillers can be further improved, as describe in Section **Variable Speed Operation**.

VSD utilize IGBT (Insulated-Gate Bipolar Transistor) technology to generate PWM (Pulse Width Modulating) signal to control the motor speed. Thus, motor starting torque can be applied precisely without over-stress the motor. Therefore, integration of VSD to DCLCD chillers not only benefits the chiller operation, it also helps on power grid and generator as it eliminates current surging during motor startup.

**Harmonic filter option** – Harmonic distortion occurs when there is VSD in the electrical distribution system. Harmonic distortion level can be treated at PCC (Point of Common Coupling) as specify by IEEE Standard 519. However, DB can provide option to include additional harmonic filter to lower the total harmonic distortion level. Harmonic filter with 5% total harmonic distortion is available on customer request to suite the applications

## Refrigerant Isolation Valves

Isolation valves are installed at refrigerant liquid line and compressor discharge line to isolate the condenser for refrigerant storage during servicing. This saves precious time on servicing as it eliminates the needs to transfer refrigerant into external refrigerant storage vessels.

## 1-pass Evaporator and Condenser

1-pass evaporator or condenser is suitable for applications with low temperature different (delta T) or high fluid flow, where the evaporators or condensers are piped in series.

## 3-pass Evaporator and Condenser

3-pass evaporator or condenser is suitable for applications with high delta T and low fluid flow.

## Flange Water Connection

Flanged water connection for evaporator and condenser water connections in lieu of standard Victaulic groove connection.

## Hot Gas Bypass

To maintain unit operation below minimum unloaded capacity.

## Marine Water Box

Marine water box for condenser, for ease of condenser tube cleaning without interfere with field water piping.

## 300psig Evaporator & Condenser

Evaporator and condenser with 300psig working pressure at water side is available to suite site installation.

## Double Thick Insulation

Evaporator with double thick 2 inch [50mm] closed cell insulation, for extra resistance to condensation.

## Vibration Isolator

Spring isolators with 1 inch [25mm] deflection is supplied for field installation. These housed spring assemblies have a neoprene friction pad at the bottom to prevent the passage of noise, and a spring locking levering bolt at the top. Neoprene inserts prevent contact between the steel upper and lower housings.

## ASME / PED Stamp

Evaporator and condenser with ASME / PED Stamp, are available on request.

## DB-CPM (Chiller Plant Manager)

DB Chiller Plant Manager (**CPM**) is a trustworthy and worry-free solution for building owners and users on chiller plant control and automation system. **CPM**'s advanced controllers monitor and control equipment in chiller plant such as chillers, primary and secondary chilled water pumps, condenser water pumps, cooling towers, variable frequency drives (VFD), motorized valves, bypass modulating valves, and etc. Field devices such as flow meters, BTU meters, digital power meters, sensors & transducers can be interfaced with **CPM** via HLI or LLI. **CPM** controls chillers, pumps and cooling towers sequencing, as well as lead-lag, duty-standby and alarm changeover operations.

**NetVisorPRO** – Monitoring software of **CPM** system which allows system monitoring, historical trending, and alarm logging to be carry out at a PC terminal. Graphical animations on system operation, temperature and flow rate trend graphs, historical data and alarm history logs, settings changes are all available with **NetVisorPRO**.

Chiller plantroom control and automation by Dunham-Bush **DB-CPM** provides the owners with a chiller system in stable operation, optimized performance and energy efficiency.



# PRODUCT SPECIFICATIONS

## DCLCD Chiller Specifications (Typical)

MODEL DCLCD		300	350	400	450	500	550	600	650	700
<b>UNIT PERFORMANCE</b>										
Nominal Cooling Capacity	TR	300	350	400	450	500	550	600	650	700
	kW	1055	1231	1407	1583	1759	1934	2110	2286	2462
Nominal Power Input	kW	167.5	190	214.5	240.3	260.8	285.7	309.2	333.5	364.3
Energy Efficiency	kW/TR	0.558	0.543	0.536	0.534	0.522	0.519	0.515	0.513	0.520
	COP	6.30	6.48	6.56	6.59	6.74	6.78	6.83	6.86	6.76
IPLV	kW/TR	0.55	0.53	0.52	0.51	0.49	0.49	0.49	0.49	0.49
	COP	6.39	6.64	6.76	6.90	7.18	7.18	7.18	7.18	7.18
<b>EVAPORATOR</b>										
Flow Rate	Usgpm	717.4	837	956.6	1076	1196	1315	1435	1554	1674
	L/S	45.26	52.81	60.35	67.88	75.46	82.96	90.53	98.04	105.61
Pressure Drop	ft.wg	22.1	21.1	20.1	19.3	19.0	22.4	15.8	16.1	18.4
	kPa	66.1	63.1	60.1	57.7	56.8	66.9	47.2	48.1	55.0
Water Connection	Victaulic (inch)	8	8	8	8	8	8	8	8	8
	Flange	DN200	DN200	DN200	DN200	DN200	DN200	DN200	DN200	DN200
Number of Passes		2	2	2	2	2	2	2	2	2
<b>CONDENSER</b>										
Flow Rate	Usgpm	901.9	1048	1196	1345	1490	1638	1785	1932	2085
	L/S	56.9	66.1	75.5	84.9	94.0	103.3	112.6	121.9	131.5
Pressure Drop	ft.wg	22.2	29.0	26.9	25.4	24.5	23.9	20.2	20.2	23.3
	kPa	66.4	86.7	80.4	75.9	73.2	71.4	60.4	60.4	69.6
Water Connection	Victaulic (inch)	8	8	8	8	8	8	10	10	10
	Flange	DN200	DN200	DN200	DN200	DN200	DN200	DN250	DN250	DN250
Number of Passes		2	2	2	2	2	2	2	2	2
<b>GENERAL</b>										
Length (L)	inch	170.9	170.9	170.9	173.4	173.4	173.4	174.1	174.1	174.1
	mm	4340	4340	4340	4400	4400	4400	4420	4420	4420
Width (W)	inch	63	63	63	74	74	74	78.5	78.5	78.5
	mm	1600	1600	1600	1880	1880	1880	1990	1990	1990
Height (H)	inch	78	78	78	82.7	82.7	82.7	89	89	89
	mm	1980	1980	1980	2100	2100	2100	2260	2260	2260
Shipping Weight	lbs	13803	13962	14240	16266	16777	16998	18794	19401	19401
	kg	6261	6333	6459	7378	7610	7710	8525	8800	8800
Operating Weight	lbs	16191	16482	17013	19656	20355	20675	22910	23761	23761
	kg	7344	7476	7717	8916	9233	9378	10392	10778	10778
R134a Charge (Approx.)	lbs	1113	1164	1237	1532	1541	1541	1539	1640	1640
	kg	505	528	561	695	699	699	698	744	744

MODEL DCLCD		750	800	850	900	950	1000	1100	1200	1300
<b>UNIT PERFORMANCE</b>										
Nominal Cooling Capacity	TR	750	800	850	900	950	1000	1100	1200	1300
	kW	2638	2814	2989	3165	3341	3517	3869	4220	4572
Nominal Power Input	kW	394.3	420.6	442.0	467.5	496.8	519.5	579.0	628.80	672.3
Energy Efficiency	kW/TR	0.526	0.526	0.520	0.519	0.523	0.519	0.526	0.524	0.517
	COP	6.69	6.69	6.76	6.78	6.72	6.77	6.69	6.71	6.80
IPLV	kW/TR	0.49	0.49	0.49	0.49	0.49	0.49	0.51	0.50	0.49
	COP	7.18	7.18	7.18	7.18	7.18	7.18	6.90	7.03	7.18
<b>EVAPORATOR</b>										
Flow Rate	Usgpm	1793.6	1913.2	2032.8	2152.3	2271.9	2391.5	2630.6	2869.8	3108.9
	L/S	113.00	120.53	128.07	135.59	143.13	150.66	165.73	180.80	195.86
Pressure Drop	ft.wg	16.1	16.4	22.9	22.9	25.2	26.8	25.7	25.8	23.5
	kPa	48.1	49.0	68.4	68.4	75.3	80.1	76.8	77.1	70.2
Water Connection	Victaulic (inch)	10	10	10	10	10	12	12	12	14
	Flange	DN250	DN250	DN250	DN250	DN250	DN300	DN300	DN300	DN350
Number of Passes		2	2	2	2	2	2	2	2	2
<b>CONDENSER</b>										
Flow Rate	Usgpm	2237.7	2386.9	2536.1	2685.3	2834.5	2983.6	3282.0	3580.4	3878.7
	L/S	141.2	150.6	160.0	169.4	178.8	188.2	207.1	225.89	244.71
Pressure Drop	ft.wg	20.2	20.3	25.6	28.3	31.1	25.7	30.4	30.0	27.9
	kPa	60.4	60.7	76.5	84.6	93.0	76.8	90.9	89.67	83.4
Water Connection	Victaulic (inch)	10	10	10	10	10	12	12	12	14
	Flange	DN250	DN250	DN250	DN250	DN250	DN300	DN300	DN300	DN350
Number of Passes		2	2	2	2	2	2	2	2	2
<b>GENERAL</b>										
Length (L)	inch	174.7	174.7	195.2	195.2	195.2	199.4	199.4	199.4	201.9
	mm	4440	4440	4960	4960	4960	5070	5070	5070	5130
Width (W)	inch	82.5	82.5	82.5	82.5	82.5	95.5	95.5	95.5	110.2
	mm	2100	2100	2100	2100	2100	2430	2430	2430	2800
Height (H)	inch	102.0	102.0	102.0	102.0	102.0	115.4	116.9	116.9	119.0
	mm	2590	2590	2590	2590	2590	2930	2970	2970	3010
Shipping Weight	lbs	22851	23182	24291	24548	24553	29355	32534	33830	38797
	kg	10365	10515	11018	11135	11137	13315	14757	15345	17598
Operating Weight	lbs	27886	28431	30075	30450	30455	36427	39919	41692	48387
	kg	12649	12896	13642	13812	13814	16523	18107	18911	21948
R134a Charge (Approx.)	lbs	1874	1942	2205	2253	2253	2646	2789	2959	3287
	kg	850	881	1000	1022	1022	1200	1265	1342	1491

**Notes:**

- The units are rated in accordance with AHRI Standard 550/590. The above data are rated with following conditions: Chilled Water Inlet/Outlet Temperature 54/44°F [12.2/6.7°C]; Cooling Water Inlet/Outlet Temperature 85/94.3°F [29.4/34.6°C]; Evaporator fouling factor 0.0001hr.ft<sup>2</sup>.°F/Btu [0.000018 m<sup>2</sup>.°C/W]; Condenser fouling factor 0.00025 hr.ft<sup>2</sup>.°F/Btu [0.0000144 m<sup>2</sup>.°C/W]; 2-pass evaporator and condenser.
- The specification is for reference purpose only. For the same cooling capacity may have different models with different performance result due to variety combination of main components. Contact local DB office to choose the appropriate chiller for the User's practical requirements.
- Dimensions lengths, width, height in mm are rounded to closest zero.



# PRODUCT SPECIFICATIONS

MODEL DCLCD		1400	1500	1600	1700	1800	1900	2000	2100	2200
<b>UNIT PERFORMANCE</b>										
Nominal Cooling Capacity	TR	1400	1500	1600	1700	1800	1900	2000	2100	2200
	kW	4924	5276	5627	5979	6331	6682	7034	7386	7737
Nominal Power Input	kW	728.3	771.6	823.9	875.6	919.4	972.1	1027.9	1051.8	1101.9
Energy Efficiency	kW/TR	0.520	0.514	0.51	0.51	0.51	0.51	0.51	0.50	0.50
	COP	6.76	6.84	6.90	6.90	6.90	6.90	6.90	7.03	7.03
IPLV	kW/TR	0.50	0.49	0.46	0.46	0.46	0.46	0.46	0.45	0.45
	COP	7.03	7.18	7.65	7.65	7.65	7.65	7.65	7.82	7.82
<b>EVAPORATOR</b>										
Flow Rate	Usgpm	3348.1	3587.2	3826.4	4065.5	4304.7	4543.8	4783.0	5022.1	5261.3
	L/S	210.93	225.99	241.41	256.49	271.58	286.67	301.76	316.85	331.94
Pressure Drop	ft.wg	26.8	26.3	24.7	22.1	24.4	22.3	24.3	20.7	19.5
	kPa	80.1	78.6	73.8	66.1	72.9	66.7	72.6	61.9	58.3
Water Connection	Victaulic (inch)	14	14	16	16	16	16	16	18	18
	Flange	DN350	DN350	DN400	DN400	DN400	DN400	DN400	DN450	DN450
Number of Passes		2	2	2	2	2	2	2	2	2
<b>CONDENSER</b>										
Flow Rate	Usgpm	4143.1	4439.0	4773.8	5072.2	5370.6	5668.9	5967.3	6214.6	6510.5
	L/S	261.39	280.06	301.18	320.01	338.83	357.65	376.48	392.08	410.75
Pressure Drop	ft.wg	27.2	30.7	29.0	32.2	28.7	31.5	29.8	27.4	29.8
	kPa	81.3	91.8	86.7	96.2	85.8	94.2	89.1	81.9	89.1
Water Connection	Victaulic (inch)	14	14	16	16	16	16	16	20	20
	Flange	DN350	DN350	DN400	DN400	DN400	DN400	DN400	DN500	DN500
Number of Passes		2	2	2	2	2	2	2	2	2
<b>GENERAL</b>										
Length (L)	inch	201.9	201.9	209.06	209.06	209.06	209.06	209.06	217.72	217.72
	mm	5130	5130	5310	5310	5310	5310	5310	5530	5530
Width (W)	inch	110.2	110.2	122.05	122.05	122.05	122.05	122.05	144.09	144.09
	mm	2800	2800	3100	3100	3100	3100	3100	3660	3660
Height (H)	inch	119.0	119.0	125.39	125.39	125.39	125.39	125.39	137.60	137.60
	mm	3010	3010	3185	3185	3185	3185	3185	3495	3495
Shipping Weight	lbs	39238	39727	48378	48923	49712	50283	51019	59926	60543
	kg	17798	18020	21944	22191	22549	22808	23142	27182	27462
Operating Weight	lbs	49011	49842	60045	61088	62322	63383	64461	75674	76767
	kg	22231	22608	27236	27709	28269	28750	29239	34325	34821
R134a Charge (Approx.)	lbs	3287	3474	3915	4125	4222	4427	4502	5229	5428
	kg	1491	1576	1776	1871	1915	2008	2042	2372	2462

MODEL DCLCD		2300	2400	2500	2600	2700	2800	2900	3000
<b>UNIT PERFORMANCE</b>									
Nominal Cooling Capacity	TR	2300	2400	2500	2600	2700	2800	2900	3000
	kW	8089	8441	8793	9144	9496	9848	10199	10551
Nominal Power Input	kW	1138.0	1195.3	1244.4	1389	1444	1481	1544	1602
Energy Efficiency	kW/TR	0.49	0.50	0.50	0.534	0.535	0.529	0.533	0.534
	COP	7.18	7.03	7.03	6.58	6.58	6.65	6.60	6.59
IPLV	kW/TR	0.44	0.45	0.44	0.46	0.46	0.45	0.46	0.46
	COP	7.99	7.82	7.99	7.66	7.66	7.74	7.70	7.69
<b>EVAPORATOR</b>									
Flow Rate	Usgpm	5500.4	5739.5	5978.7	6909	7175	7440	7706	7972
	L/S	347.02	362.11	377.20	435.89	452.67	469.39	486.17	502.96
Pressure Drop	ft.wg	21.0	19.8	21.3	22.6	24.2	23.6	25.1	24.5
	kPa	62.8	59.2	63.7	67.6	72.3	70.5	75.0	73.2
Water Connection	Victaulic (inch)	18	18	18	20	20	20	20	20
	Flange	DN450	DN450	DN450	DN500	DN500	DN500	DN500	DN500
Number of Passes		2	2	2	2	2	2	2	2
<b>CONDENSER</b>									
Flow Rate	Usgpm	6806.4	7102.4	7398.3	8031	8340	8637	8953	9265
	L/S	429.42	448.09	466.76	506.68	526.17	544.91	564.85	584.53
Pressure Drop	ft.wg	27.2	29.3	26.9	24.5	23.8	25	24.2	25.7
	kPa	81.3	87.6	80.4	73.2	71.1	74.7	72.3	76.8
Water Connection	Victaulic (inch)	20	20	20	20	20	20	20	20
	Flange	DN500	DN500	DN500	DN500	DN500	DN500	DN500	DN500
Number of Passes		2	2	2	2	2	2	2	2
<b>GENERAL</b>									
Length (L)	inch	217.72	217.72	217.72	219.09	219.09	219.09	219.09	219.09
	mm	5530	5530	5530	5565	5565	5565	5565	5565
Width (W)	inch	144.09	144.09	144.09	134.65	134.65	134.65	134.65	134.65
	mm	3660	3660	3660	3420	3420	3420	3420	3420
Height (H)	inch	137.60	137.60	137.60	137.32	137.32	137.32	137.32	137.32
	mm	3495	3495	3495	3488	3488	3488	3488	3488
Shipping Weight	lbs	61458	62098	62891	57477	57915	58246	58833	59053
	kg	27877	28167	28527	26071	26270	26420	26686	26786
Operating Weight	lbs	78141	79256	80522	77071	77768	78407	79296	79909
	kg	35444	35950	36524	34959	35275	35565	35968	36246
R134a Charge (Approx.)	lbs	5527	5728	5831	5842	5842	5957	5957	6155
	kg	2507	2598	2645	2650	2650	2702	2702	2792

**Notes:**

- The units are rated in accordance with AHRI Standard 550/590. The above data are rated with following conditions: Chilled Water Inlet/Outlet Temperature 54/44°F [12.2/6.7°C]; Cooling Water Inlet/Outlet Temperature 85/94.3°F [29.4/34.6°C]; Evaporator fouling factor 0.0001hr.ft<sup>2</sup>.°F/Btu [0.000018 m<sup>2</sup>.°C/W]; Condenser fouling factor 0.00025 hr.ft<sup>2</sup>.°F/Btu [0.0000144 m<sup>2</sup>.°C/W]; 2-pass evaporator and condenser.
- The specification is for reference purpose only. For the same cooling capacity may have different models with different performance result due to variety combination of main components. Contact local DB office to choose the appropriate chiller for the User's practical requirements.
- Dimensions lengths, width, height in mm are rounded to closest zero.

# CHILLER DIMENSIONS

## DCLCD Dimensions And Service Clearance

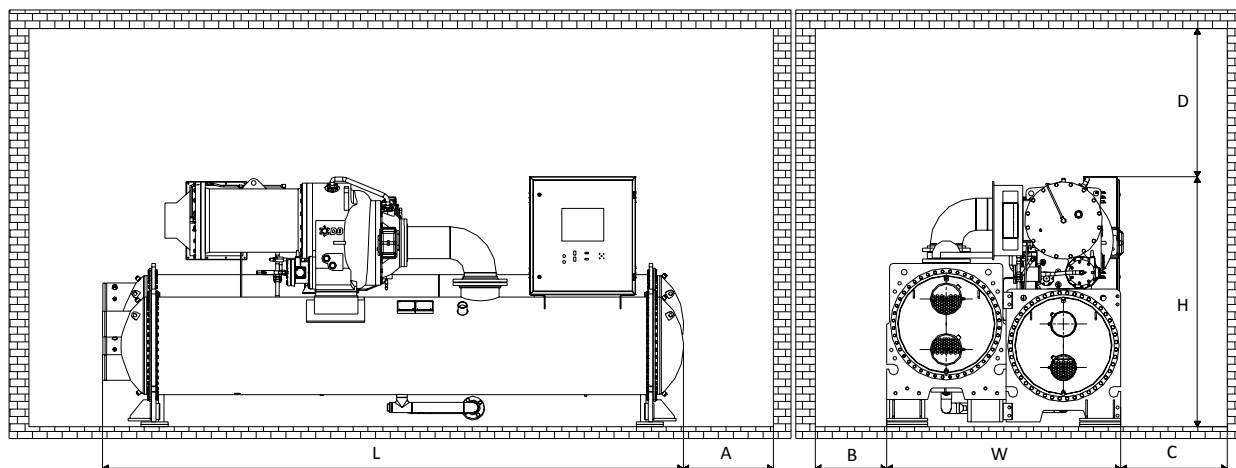

**Notes:**

- The above drawings show general construction of a DCLCD chiller with reference to chiller configuration published in [PRODUCT SPECIFICATIONS – DCLCD Chiller Selection Sample](#).
- Chiller dimensions (W- width, L – Length, H – Height) can refer from the same section with reference to unit dimensions as per selection sample published.
- Recommended service clearance:  
 Maintenance space (A) – 3400mm [134"] (DCLCD850 and below); 3800mm [150"] (DCLCD900 and above)  
 Maintenance space (B) – 375mm [15"]  
 Maintenance space (C) – 635mm [25"]  
 Overhead service clearance (D) – 1350mm [53"]
- The above constructions and dimensions are based on standard water side design pressure of 150PSIG [10.3BAR], with 2-pass evaporator and condenser.
- Service access should be provided in accordance with American Society of Heating, Refrigeration, and Air Conditioning Engineers (ASHRAE) 15, latest edition, National Fire Protection Association (NFPA) 70, and local safety code.
- Compressor motor starter panel is not shown in this drawing.
- Certified drawings available upon request. Drawings included in this section are for preliminary layout purposes only. Detailed certified drawings are available from the local DB sales office. Do not use these input for final construction drawings.

## APPLICATION DATA

### LOCATION

DCLCD chillers are design with NEMA 1 rated on chillers, control enclosure and main motor starter enclosure. This is suitable for installation in an indoor or weather protected area only. The temperature of storage area and operating plantroom shall be within below specified limits. Chiller plantroom shall have good ventilation and low humidity, maximum humidity allowed is 95%RH non-condensing.

	Minimum	Maximum
Storage and Transportation	-4°F [-20°C]	122°F [50°C]
Chiller room ambient	32°F [0°C]	104°F [40°C]

### OPERATING LIMITS

The DCLCD chillers shall be operated within below temperature limits.

	Minimum	Maximum
Evaporator Inlet Water Temperature	46°F [8°C]	77°F [25°C]
Evaporator Outlet Water Temperature	39°F [4°C]	59°F [15°C]
Condenser Inlet Water Temperature	60°F [15.6°C]	93°F [34°C]
Condenser Outlet Water Temperature	71.5°F [22°C]	105.8°F [41°C]

### SOUND AND VIBRATION

Sound level of the DCLCD is not published in this catalogue. However, it is available on the performance summary printout. Please contact your local DB representative for the information.

DCLCD series is designed and run tested to have maximum vibration less than 3mm/second, which is significantly better than the industry norm.

Vibration isolators such as spring isolators are offered as optional accessories to suite dedicated site installation.

### WATER QUALITY

The cooling water quality is an important part of the centrifugal unit maintenance. If the quality is poor, there will be scaling, mud sediment, corrosion as well as micro-organism reproduction etc. Scale and mud heavily affects the normal operation of the unit, will decrease the heat transfer coefficient of copper tubes and refrigerating capacity and increase the energy

## APPLICATION DATA

consumption. It also decreases the flowing area and increases the water resistance. The corrosion could lead to pipe perforation and water leakage in the unit possibly resulting in shut down of the unit for tube repair. Regular and reliable monitoring of the cooling water quality is recommended for the long term reliable operation of the unit. It is also advised that comprehensive consideration for water treatment is required by referring to water treatment for circulating cooling water treatment method or by consulting your local DB Sales and Service personnel.

### EVAPORATOR FLUID CIRCUIT

The evaporator fluid circuit requires a minimum system fluid volume of 3 US gallons per Ton [3.3 liters/ cooling kW] for stable operation. The minimum system fluid volume may increase up to 10 US gallons per Ton [11 liters/ cooling kW] for process cooling, low load applications with small temperature range and/or vastly fluctuating load conditions.

#### Variable Evaporator Flow

Dunham-Bush chillers are capable for variable evaporator flow system. The chiller may operate to maintain constant leaving fluid temperature with evaporator flow rate changes, with below conditions fulfilled.

- ✿ Evaporator fluid flow rate is within minimum and maximum flow rate of the unit at all time during the operation
- ✿ Rate of flow change shall not exceed 30% per minute

The chillers are able to tolerate with transient flow change up to 50% per minute, which may happen during stage up or down chillers that are connected to common header. However, such flow rate change is prohibited other than this condition considering better system stability and temperature setpoint control.

Failure to comply with the above conditions will cause problem to the chiller operation and may cause the chiller to shutdown.

### CONDENSER FLUID CIRCUIT

The unit shall work with constant condenser flow, variable condenser flow is not recommended. Variable condenser flow will keep condenser pressure high at the chiller, and thus, decreases chiller's efficiency and increase power consumption of the system. In addition, variable condenser flow increases rate of fouling of condenser, which will de-rate chiller performance and increase unit maintenance cost.

### VENT AND DRAIN CONNECTIONS

Waterboxes are fabricated using the nozzle-in-head arrangement and are supplied with vent and drain connections on the dome head. Marine waterboxes are supplied with vent and drain connections on the waterbox shells.

Vents should be provided on the chilled water as high as possible in the system and drains should be located as low as possible to ensure ease of servicing and maintenance. Where shutoff valves are provided in the main water pipes near the unit, only minimal amount of system water will be lost when the heat exchangers are drained. This reduces the time required for drainage and saves on the cost of re-treating the system water.

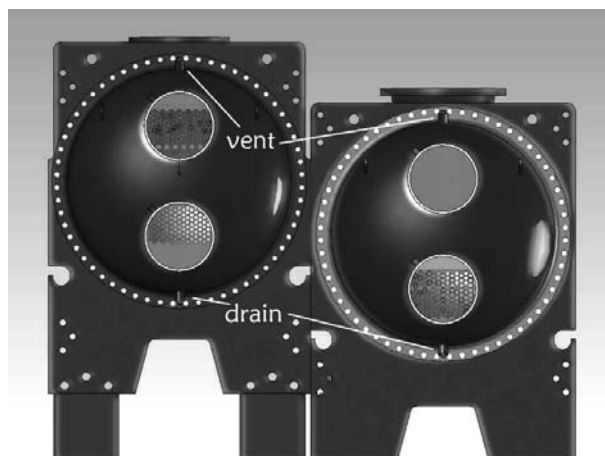

### REFRIGERANT SAFETY VALVE / PRESSURE RELIEF VALVE (PRV)

Pressure relief or safety valve connection sizes are NPT1 (DN25) for the DCLCD evaporator and condenser. The relief setting is 12.8 bar.

All Safety Valves must be piped to the outside of the building in accordance with ANSI/ASHRAE Standard 15.

Twin pressure relief valves mounted on a changeover valve, are used on the condenser so that one PRV can be shut off and removed for testing or replacement, leaving the other in operation. Only one of the two valves is in operation at any time. Where 4 valves are shown, on some large vessels, they consist of two PRV's mounted on each of two transfer valves.

Only two PRV's of the four are active at any time.

Vent piping is sized for only one valve of the set since only one can be in operation at a time.

Per ASHRAE Standard 15, the pipe size cannot be less than the relief device. The discharge from more than one Safety Valve can be run into a common header, the area of which shall not be less than the sum of the areas of the connected pipes.

For further details, refer to ASHRAE Standard 15. The common header can be calculated by the formula:

$$D_{Common} = \left( D_1^2 + D_2^2 \dots D_n^2 \right)^{0.5}$$

The above information is a guide only. Consult local codes and/or latest version of ASHRAE Standard 15 for sizing data.



# APPLICATION DATA

## The Safety Valve Locations

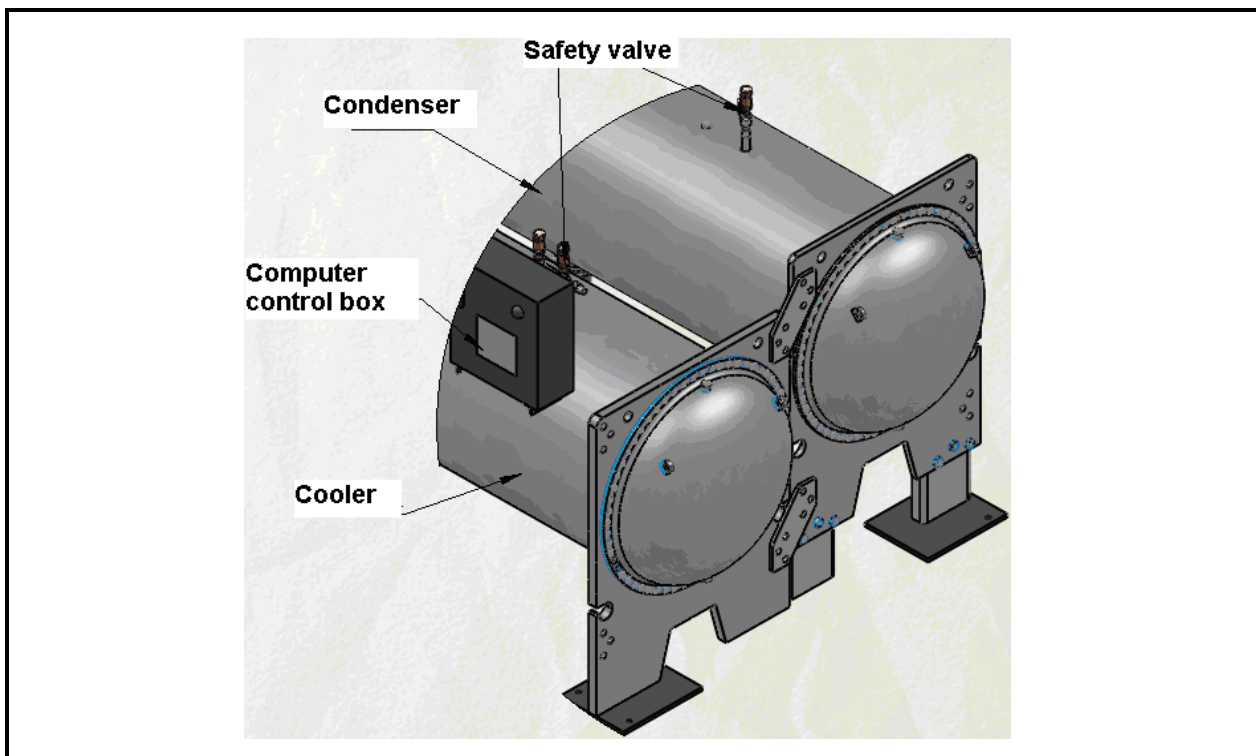

### Condenser Pressure Control

Cooling tower control is increasingly becoming an overlooked subject, and it causes problems. The following is a general recommendation that is applicable to all standard packaged chillers.

Most chiller manufacturers recommend that condenser water be controlled so that its temperature never goes below 55°F [12.8°C] (even when the machine is off) and that its rate of change is not rapid. Rapid can be defined as not exceeding 2°F [1.1°C] per minute. This is necessary because a chiller operates in a dynamic environment and is designed to maintain a precise leaving chilled water temperature under varying entering chilled water conditions. The additional dynamic of rapidly varying condenser water temperature subjects the machine to fluctuating pressure on differentials across the evaporator and condenser. This varies the refrigerant flow and, therefore, the capacity. If this occurs faster than the machine can accommodate it, the condenser pressure or evaporator pressure will soon exceed their safety setpoints and the machine will shut down.

The necessary control can sometimes be attained via fan cycling if the tower is rated at the same capacity as the chiller's heat rejection. On multiple chiller jobs, a single tower is oversized relative to the chiller. On other jobs the tower/chiller might be oversized to the design load and the chiller and tower frequently cycle under light load. Under these conditions, fan cycling might result in very rapid temperature swings, which creates a dynamic situation to condenser, which potentially cause unstable

operation. Thus, in this case, either variable speed fans or modulating valve control should be used to regain control of the condenser water. Either type of control provides precise modulating control of the condenser water rather than on-off step control. The control can be initiated either by a condenser water temperature sensor or controller.

It is further recommended that the condenser water pump be cycled by the chiller. This is to eliminate potentially very cold water from going through the condenser while the chiller is shut down. At the same time it is probable that relatively warmer chilled water is in the evaporator (an inversion). Refrigerant tends to migrate if there is a difference in pressures within the components of the chiller. It will seek the lowest pressure area of the packaged chiller which, in this case, would be the condenser. Starting of a chiller where the refrigerant has migrated to the condenser is not desirable. The presence of highly subcooled liquid refrigerant in the condenser will cause low suction pressures and possibly liquid slugging of the compressor. If the condenser water pump is off until prior to the chiller starts, the water in the condenser is at the chiller room ambient, which is usually much closer to the evaporator water temperature.

Thus, even though there has been a trend toward fan cycling control of cooling towers, it is not a device that is suitable to every installation. We recommend that the designer carefully evaluate the system to determine if a more precise method of control is indicated. If there is any doubt, the more precise control is required.

# GUIDE SPECIFICATIONS

## SCOPE

Supply and commissioning of complete factory assembled water cooled centrifugal compressor chiller (s). The centrifugal chiller(s) shall contain centrifugal compressor(s), evaporator, condenser, interconnecting refrigerant piping, expansion device(s), inlet guide vanes, control panel, chilled liquid connections, and condenser water connections. The control panel shall be fully wired by the manufacturer connecting & interlocking controller, starter, electrical protection devices with electrical power and control connections. The starter may be supplied separate for field installation. Packaged chiller shall be factory assembled, charged and tested with a full operating refrigerant and oil charge. Upon successful completion the testing, the refrigerant shall be recovered from the chiller and leaving sufficient holding refrigerant charge above atmospheric pressure prior to the shipment. The refrigerant type shall be R134a and shall not have phasing out schedule.

Capacity of each chiller shall be not less than \_\_\_\_\_ refrigerant tons (kW output) cooling at \_\_\_\_\_ USGPM (liters/min.) of water from \_\_\_\_\_ °F[°C] to \_\_\_\_\_ °F[°C]. Power input requirements for the unit(s), incorporating all appurtenances necessary for unit operation, including but not limited to the control accessories and pumps, if required, shall not exceed \_\_\_\_\_ kW input at design conditions. The unit shall be able to unload to 20% of cooling (refrigeration) capacity when operating with leaving chilled water temperature and at condenser water entering temperatures as per AHRI relief. The unit shall be capable of continuous operation at this point, with stable compressor operation, without the use of hot gas bypass.

Heat transfer surfaces shall be selected to reflect the incorporation of a fouling factor of 0.00025 hr.sq.ft.°F/BTU [0.000044m<sup>2</sup>.°C/W] for the water condenser and 0.0001 hr.sq.ft.°F/BTU [0.0000176m<sup>2</sup>.°C/W] for evaporator. Water pressure drop at design conditions shall not exceed \_\_\_\_\_ feet of water through the condenser, and \_\_\_\_\_ feet of water through the evaporator.

## QUALITY ASSURANCE

- ✿ Chiller performance shall be certified by AHRI as per AHRI 550/590 standard latest edition
- ✿ ASHRAE Standard 15 safety code for mechanical refrigeration
- ✿ ASME standard B31.5 for Refrigerant piping
- ✿ Vessels shall be fabricated and pressure tested in accordance with ASME Boiler and Pressure vessel code, Section VIII, Division 1 "Unfired Pressure Vessels"
- ✿ [Optional] ASME stamp on pressure vessels
- ✿ [Optional] PED certification required in Europe market place
- ✿ Unit shall be manufactured in ISO9001 registered manufacturing facility

- ✿ Factory run test: Chiller shall be pressure tested, evacuated and fully charged with refrigerant and oil. The chiller shall be run tested with water flowing through the vessels. The chiller needs to be tested either with the starter if the chiller is supplied with them

- ✿ Manufacturer shall have a strong service organization with trained service personal

## DELIVERY, STORAGE AND HANDLING

Unit shall be delivered to job site fully assembled with all interconnecting refrigerant piping and internal wiring ready for field installation and with refrigerant holding charge and oil by manufacturer. When delivered, machine shall be stored indoors, away from construction dirt, dust, moisture or any other hazardous material that would harm the chillers. Inspect under shipping tarps, bags, or crates to be sure there is no water collected during transit. Protective shipping covers shall be kept with the unit until machine is ready for installation.

## WARRANTY

Chiller manufacturer's warranty shall cover for 12 months from the date of start-up or 18 months from the date of shipment whichever is first. The start-up shall be carried out by an authorized service personnel and the warranty is limited to part replacement excluding labor and consumables such as refrigerant, oil & filter driers etc.

## MAINTENANCE

Maintenance of the chillers will be responsibility of the owner and performed in accordance with the manufacturer's instructions.

## OPERATING REQUIREMENT

The unit shall be capable of starting up with entering fluid temperature to the cooler at 93°F [34°C].

Minimum and maximum transportation and storage temperature of the chiller shall be -4°F [-20°C] and 122°F [50°C].

Unit shall be able to operate with 3-ph \_\_\_\_\_ Hz with unit rated voltage +/- 10%.

Control Voltage shall be 230V/1ph/50Hz or 230V/1ph/60Hz.

## COMPRESSOR AND MOTOR

The packaged chiller shall be furnished with dual stage semi-hermetic dynamic centrifugal compressor(s) to suit the desired design requirement. The compressor shall be driven by a 2 pole motor (2900 RPM @ 50Hz; 3600 RPM @ 60Hz).

The impeller shall be statically and dynamically balanced. The compressor shall be vibration tested and shall not exceed 4mm/s.

# GUIDE SPECIFICATIONS

---

The impeller shall be cast from special super high density aluminum alloy, light weight, high anti-corrosion ability. It shall have high efficient, back sweep main blades and low profile intermediate splitter blades, contoured aerodynamically to improve compressor full load and part load operating efficiency. Compressor shall complete with a backward inclined impeller and the compressor speed shall be increased to meet the required capacity and lift by using a single set of helical gears. The gears shall be especially engineered helical, crowned teeth, shall ensure that more than one tooth is in contact at all times for even distribution of load and for quieter operation. Gear tooth surfaces are case hardened and precision ground to AGMA class 11. Gears are integrally assembled in the compressor rotor support and are film lubricated. Each gear is individually mounted in its own journal and thrust bearings to isolate it from impeller and motor forces. The double layer compressor case design reduce the gear contacting noise. The drive gears shall operate in a controlled lubricant mist atmosphere that shall effectively cools and lubricate them.

The bearings shall be consisting of steel-backed babbitt-lined sleeve bearings, and special composite bearings ensure smooth, reliable operation over the life time of the chiller.

Non-contact labyrinth shaft seal shall be used for reducing the flow of gas from an area of high to low pressure. It shall involve a stationary labyrinth in close proximity to a rotating shaft.

Compressor shall have a reliable lubrication system which shall include integral oil pump, changeable oil filter, oil sump, oil heater, educator- jet pump and sight glass. A reliable compact, lightweight oil pump with lower pressure fluctuations and higher volumetric efficiency shall be used for maintaining required oil pressure and flow throughout the lubrication system to maintain the bearing lubrication in the compressor and motor. The lubrication system shall complete with reliable oil recovery system to bring back the oil accumulated in the cooler and other locations to the oil sump. Oil sump shall be provided with an integral electric oil heater with the compressor to maintain oil temperature of 95°F ~ 131°F [35°C ~ 55°C] during shutdown period in order to prevent oil dilution which may causes decrease in viscosity. The heater shall be energized by a sensor whenever the oil temperature in the sump is lower than the set value. Power to the oil heater/controls shall be on circuits that can provide continuous power supply when the compressor is disconnected and the chiller is switched off. In case of power interruption for longer period oil heater shall be energized for at least 24hrs to raise the oil temperature. Oil shall also be cooled during operation to the required temperature by sub cooled liquid refrigerant expansion. A plate type heat exchanger shall be used for this purpose.

An emergency oil reservoir shall be provided in order to maintain adequate lubrication flow under gravity, and prevent bearing damage that could occur during the

coast down period, in the event of power failure or pump malfunction.

The control system shall prevent compressor starting until proper oil pressure and proper oil temperature is achieved.

Capacity control shall be achieved by adjusting the degree of opening of the inlet guide vanes, thereby adjusting the volume flow rate. The guide vanes shall be connected with aircraft-quality cable and controlled by precise electronic actuator. It shall be able to maintain chilled fluid leaving temperature within a narrow dead band of the desired set point without surging or undue vibration. The vanes shall be able to regulate refrigerant flow through a wide stable operating range.

For unit equipped with Variable Speed Drive (VSD), compressor motor speed shall be reduce to minimum possible speed before inlet guide vane to starts closing. The controller shall be capable to perform combined action of both VSD and inlet guide vane to deliver stable operation with optimized efficiency.

The compressor motor shall be closed-coupled hermetic, 2 pole, squirrel cage induction type. The motor shall have efficient refrigerant cooling system with spray nozzles, eliminating the need for additional equipment for motor cooling in the machine room. Motor winding shall have reliable corrosion resistant insulation which shall compatible with refrigerant and oil. The motor shall be protected by a temperature sensor imbedded in the stator windings.

## EVAPORATOR

Evaporator vessel shall be cleanable shell and tube, flooded type. Shell shall be fabricated from rolled carbon steel sheet with fusion welded seams or carbon steel standard pipes. End plates shall be of carbon steel with precision drilling, reamed in order to accommodate tubes. Intermediate tube support shall be in place to provide required tube support between tube sheets. Tubes shall be of copper, seamless, high efficient, internally enhanced and externally finned, mechanically expanded into fixed steel tube sheets. Tube diameter shall be ¾ inch [19mm], 1 inch [25mm] and thickness shall be 0.025 inch [0.635mm]. The flooded evaporator shall have a built in distributor for feeding refrigerant evenly under the tube bundle to produce a uniform boiling action and baffle plates shall be provided to ensure vapor separation. Water box shall be removable for tube cleaning, shall have stub-out water connections with Victaulic grooves in compliance to ANSI/ AWWAC-606. They are to be available in single, two or three pass design as required on the drawings. Vent and drain plugs are to be provided in water box. The shell side of the evaporator shall have pressure relief valve with provision for refrigerant venting. Evaporators refrigerant side shall be designed, constructed in accordance with the ASME Code for Unfired Pressure Vessels. Evaporator shell side shall undergo pneumatic pressure test,

# GUIDE SPECIFICATIONS

---

at 220psig [15.2Bar] shall be designed for working pressure up to 200psig [13.8Bar]. Tube side shall undergo hydrostatic pressure test at 195psig [13.4Bar], shall be designed for 150psig [10.3BAR] working pressure.

The flooded evaporator shall have an efficient and reliable oil recovery system. The oil recovery system shall insure the evaporator is operating at peak efficiency at all times and provide optimal energy efficiency during extended periods of part load. Units without such oil recovery systems will not be acceptable.

## [OPTIONAL]

- A. Evaporator Flanged Water Connection – Flanged water connection shall be provided in lieu of Victaulic groove connection
- B. Double Thick Insulation – Evaporator shall be provided with 2 inch [50mm] thick closed cell insulation for extra resistance to condensation
- C. 1 inch tube diameter – Selection of larger diameter to minimize water pressure drop
- D. Marine Water Box – Marine type water box shall be provided for removal of the end covers of the vessel without dismantling the piping to facilitate tube cleaning
- E. PED Compliance – Evaporator with PED approval shall be provided for installation in European countries

## CONDENSER

Condenser vessel shall be cleanable shell and tube. Shell shall be fabricated from rolled carbon steel sheet with fusion welded seams or carbon steel standard pipes. End plates shall be of carbon steel with precision drilling, reamed in order to accommodate tubes. Intermediate tube support shall be in place to provide required tube support between tube sheets. Tubes shall be of copper, seamless, high efficient, internally enhanced and externally finned, mechanically expanded into fixed steel tube sheets. Tube diameter shall be ¾ inch [19mm], 1 inch [25mm] and thickness shall be 0.025 inch [0.635mm]. Water box shall be removable for tube cleaning, shall have stubout water connections with Victaulic grooves in compliance to ANSI / AWWAC-606. They are to be available in single, two pass or three pass design as required on the drawings. Vent and drain plugs are to be provided in water box. The shell side of the condenser shall have pressure relief valve with provision for refrigerant venting. Condenser refrigerant side shall be designed, constructed in accordance with the ASME Code for Unfired Pressure Vessels. Condenser shell side shall undergo pneumatic pressure at 220psig [15.2Bar], shall be designed for working pressure up to 200psig [13.8Bar]. Tube side shall undergo hydrostatic pressure test at 195psig [13.4Bar], shall be designed for 150psig [10.3BAR] working pressure.

The condenser shall have baffle that prevent direct impingement of high velocity refrigerant gas flow from the compressor onto condenser tubes. It shall also eliminates the related vibration and wear of the tubes and distributes the refrigerant flow evenly over the length of the vessel for improved efficiency.

The condenser shall have sub-cooler located in the bottom of the condenser; increase the overall refrigerant effect of the chiller by sub-cooling the condensed liquid refrigerant which results in a combination of increasing capacity and improving the efficiency.

The condenser shall be sized for full pump down capacity.

## [OPTIONAL]

- A. Evaporator Flanged Water Connection – Flanged water connection shall be provided in lieu of Victaulic groove connection
- B. Marine Water Box – Marine type water box shall be provided for removal of the end covers of the vessel without dismantling the piping to facilitate tube cleaning
- C. 1 inch tube diameter – Selection of larger diameter to minimize water pressure drop
- D. PED Compliance – Evaporator with PED approval shall be provided for installation in European countries
- E. Refrigeration Isolation Valves – Refrigerant isolation valve shall be provided to enable the entire unit refrigerant charge to be storage in the condenser enabling service and maintenance activities to be completed in less time and lower cost

## REFRIGERANT CIRCUIT

The refrigerant circuit shall include (OPTION) liquid and discharge line isolation valves (which facilitate full pump down capacity in the condenser), oil filter, replaceable filter drier on oil line, sight glass on oil line, pressure relief valves on the cooler and condenser, liquid line angle valve for refrigerant charging. The packaged chiller shall be furnished with a simple reliable fixed orifice expansion device with no moving parts for refrigerant flow control.

## OIL MANAGEMENT

The compressor shall have an independent lubrication system to provide lubrication to all parts requiring oil. The lubricating system shall have a positive displacement, compact light weight oil pump that shall be powered through the unit control transformer. The oil sump shall complete with oil heater to maintain sufficient oil temperature to minimize the oil dilution. It shall also include a plate type heat exchanger as oil cooler. An efficient oil recovery system shall be in place with interconnecting oil pipes together with required educator-jet-pump to recover oil from cooler and other locations in the chiller back to the oil sump.

# GUIDE SPECIFICATIONS

## ELECTRICAL AND CONTROL PANEL

The electrical switch gears, controller, control sensors and relays shall be housed in NEMA-1 panel. The panel casing shall be of galvanized steel with powder coating for corrosion resistance. The panel shall be divided into two separate compartments or shall have two separate panels to house power and control devices separately.

## OPTIONAL COMPRESSOR MOTOR STARTER PANEL

The chiller manufacturer shall provide suitable starter for the compressor motor in order to minimize the starting current. The starter shall be factory built fully wired as stipulated under starter section elsewhere in this specification. The starter shall be able to provide adequate starting torque and the required acceleration for the compressor during starting.

NEMA-1 electrical panel compartment shall include:

- ✿ Main incoming power terminal suitable to receive single entry of three phase 3-wire power supply with specified voltage
- ✿ Circuit breakers for the compressor
- ✿ Solid state compressor motor over Current protection module
- ✿ Compressor motor overheat protection module
- ✿ Under/over voltage phase reversal and imbalance relay
- ✿ [Optional] Ground fault interrupter

The main motor starter shall be factory built to the chiller component and factory tested during the run test of the unit. The main motor starter is shipped loose for floor mounting and field wiring to the chiller package. It shall be free standing designed for top entry and bottom exit and with front access. Optional unit mounted motor starter panel shall be offered by the manufacturer for LV application, for the ease of field installation.

The compressor starter and circuit breakers shall be wired securely to the main incoming terminal block. External compressor over load protector, over heating protection modules, over/under voltage phase relay shall be interlocked with the compressor starter contactors to provide adequate protection to the compressor motor.

## Low Voltage Starter (up to 575Vac)

### A) Star-Delta Starter (Closed Transition) up to 460Vac

Star-Delta Starter with open transition shall not be accepted due to high changeover inrush current.

Contactors and resistors shall be properly sized to ensure smooth transition. Transition timer should be selected with adjustable 30 seconds range for proper changeover setting.

### B) Solid State Starter (Softstarter)

The starter shall be furnished with SCRs (silicon

controlled rectifier), or also known as thyristors to limit the current flow during motor starting. The starter shall be furnished together with bypass contactor. When the motor starting cycle is completed (motor has reached operating speed), the bypass contactor shall be energized and disconnect SCRs from the power circuit during normal motor operation.

## C) Variable Speed Drive (VSD) up to 575Vac

The chiller shall be capable for variable speed operation if VSD starter is supplied.

The VSD shall be constant torque type and able to deliver 110% torque for 60 seconds during normal operation. Displacement power factor of motor shall be improved to minimum level of 0.95 at all operating conditions.

VSD shall meet EMC product standard EN61800-3, and harmonic requirement as per IEC/EN 61000-3-12.

VSD shall have inbuilt protection mode which automatically reduce the frequency and the modulation process adjusted when it detects critical status such as over current or over voltage etc.

VSD shall have inbuilt Electronic thermal motor protection against overload. The VSD shall be protected against short-circuits on motor terminals U, V, W. It shall also Protection against mains phase loss.

The VSD shall have built-in LCD keypad display with below information available:

- ✿ Motor current
- ✿ Voltage / frequency output
- ✿ Output kW
- ✿ Output frequency
- ✿ Fault log

## Medium Voltage Starter (3kV up to 13.8kV)

### A) Direct-On-Line Starter (DOL)

Contactors shall be properly sized to allow Lock Rotor Current (LRA) flows to motor during start-up.

### B) Auto-Transformer Starter

Auto-transformer shall be supplied with properly sized contactors and transformer with factory wired to 65% tapping.

### C) Solid State Starter (Softstarter)

The starter shall be furnished with SCRs (silicon controlled rectifier), or also known as thyristors to limit the current flow during motor starting. The starter shall be furnished together with bypass contactor. When the motor starting cycle is completed (motor has reached operating speed), the bypass contactor shall be energized and disconnect SCRs from the power circuit during normal motor operation.

# GUIDE SPECIFICATIONS

## D) Variable Speed Drive (VSD)

The chiller shall be capable for variable speed operation if VSD starter is supplied.

The VSD shall be constant torque type and able to deliver 110% torque for 60 seconds during normal operation. Displacement power factor of motor shall be improved to minimum level of 0.95 at all operating conditions.

VSD shall meet EMC product standard EN61800-3, and harmonic requirement as per IEC/EN 61000-3-12.

VSD shall have inbuilt protection mode which automatically reduce the frequency and the modulation process adjusted when it detects critical status such as over current or over voltage etc.

VSD shall have inbuilt Electronic thermal motor protection against overload. The VSD shall be protected against short-circuits on motor terminals U, V, W. It shall also Protection against mains phase loss.

The VSD shall have built-in LCD keypad display with below information available:

- ✿ Motor current
- ✿ Voltage / frequency output
- ✿ Output kW
- ✿ Output frequency
- ✿ Fault log

## CONTROL SYSTEM

The packaged chiller shall be equipped with standalone proactive advance Microprocessor based DDC controller which adapts to abnormal operation conditions. It shall have built in Input/Output, BMS communication port. The unit algorithm program and operating parameters shall be stored in non-volatile memory. Battery back-up is not acceptable. 24Vac 45VA power supply to the controller shall be provided by a control transformer provided with the panel. The controller shall be equipped with a user friendly 10.1 inch color touch screen display and dedicated touch keys that provides easy access to the unit operating parameters, control set points and alarm history, based on security level of password. There shall be password protection for operator, service personnel and for the critical manufacturer settings in order to protect the chiller controller from unauthorized access.

The controller board shall be provided with a set of terminals that connected to various devices such as temperature sensors, pressure transducers, current transducers, valves, compressor starter, control relays.

The controller shall be able to carry out its own diagnose test on the controller and the connected devices and alarm messages shall be displayed automatically on faulty devices.

All messages shall be displayed in English language, and shall be displayed either in Imperial or SI units.

Leaving chilled water temperature control shall be accomplished by entering the water temperature set point with accuracy to  $\pm 0.25^{\circ}\text{C}@25^{\circ}\text{C}$  ( $\pm 0.45^{\circ}\text{F}@77^{\circ}\text{F}$ ) and placing the controller automatic control mode. The controller shall monitor all control functions and move the compressor IGV or VFD (if supplied) or both to the calibrated position. The compressor loading cycle shall be programmable and shall be adjusted to the building load requirement. The loading IGV adjustable range shall be from 0.1% to 0.5% per increment to prevent excessive demand hike at start up.

The controller shall continuously monitor evaporator leaving/entering water temperature, condenser leaving/entering temperature, evaporator and condenser pressure; compressor amp draw; oil temp; oil pressure; motor temp and discharge refrigerant temperature. The controller shall complete with all hardware and software necessary to enable remote monitoring of all data through the Building Management Systems with open protocol Modbus RTU, and optional BMS links: Bacnet Over IP, Modbus TCP/IP, LonWorks, or BACnet MSTP. The controller shall be complete with a RS485 communications port, the remote connection shall be established by a twisted pair of wire. The controller shall also accept a remote start and stop signal, chilled water temperature reset signal (optional) and compressor current limit reset signal (optional).

The electrical control panel shall be wired to permit fully automatic operation during - initial start-up, normal operation, and shutdown conditions. The control system shall contain the following control, displays and safety devices:

### Manual/Auto Controls

- ✿ Auto/Local/Remote switch
- ✿ Control circuit stop and start switches
- ✿ Compressor enable switch
- ✿ Compressor over current
- ✿ Compressor anti-recycle (15 minutes between each start)
- ✿ Programmable with Seven day operation cycle
- ✿ Chilled water pump on/off control
- ✿ Condenser water pump on/off control
- ✿ Oil pump starter
- ✿ Start delay timer
- ✿ Anti-recycle timer
- ✿ Oil sump heater interlock relays

### Refrigerant Flow Controls

- ✿ Compressor loading and unloading shall be carried out by inlet guide vanes actuator
- ✿ For unit with Variable Speed Drive (VFD), compressor capacity control shall be carried out by VFD and Inlet Guide Vane actuators

# GUIDE SPECIFICATIONS

---

## System Operation Information

The chiller display shall provide following operating information.

### Analog Readings

- ✿ Leaving chilled water temperature
- ✿ Entering chilled water temperature
- ✿ Leaving condenser water temperature
- ✿ Entering condenser water temperature
- ✿ Cooler and condenser pressure
- ✿ Cooler and condensation saturation temperature
- ✿ Motor temperature
- ✿ Motor bearing temperature
- ✿ Discharge temperature
- ✿ Discharge superheat
- ✿ Condenser and cooler approach temperature
- ✿ Condenser and cooler superheat
- ✿ Running amps
- ✿ Percentage of the full load Amps
- ✿ Inlet guide vane open degree
- ✿ Liquid modulating valve opening degree
- ✿ Vapor injection opening degree
- ✿ Hot gas bypass opening degree
- ✿ Water temperature set value
- ✿ Oil sump temperature
- ✿ Oil sump pressure
- ✿ Oil sump superheat
- ✿ Oil pressure difference
- ✿ Cooler and condenser pressure ratio
- ✿ Power up delay time
- ✿ Refrigerant leak (optional)
- ✿ Suction temperature (optional)
- ✿ Liquid line temperature (optional)
- ✿ Liquid line pressure (optional)
- ✿ Subcooling temperature (optional)
- ✿ System voltage monitoring (optional)

### Status Compressor Run/Stop Status

- ✿ Compressor alarm status
- ✿ Oil pump alarm status
- ✿ Oil pump status
- ✿ Oil heater status
- ✿ Vapor injection open/close status
- ✿ Inlet guide vane open/close status
- ✿ Hot gas bypass open/close status
- ✿ External stop/start command status
- ✿ Chilled water pump status
- ✿ Condenser water pump status
- ✿ Chilled water flow
- ✿ Condenser water flow
- ✿ Cooling tower

### Set Points

- ✿ Leaving chilled water temperature setpoint
- ✿ Leaving chilled water temperature control band
- ✿ Unit measurement (SI unit or Imperial)
- ✿ Compressor on/off switch
- ✿ Weekly operating schedule
- ✿ Chilled water temperature reset (optional)
- ✿ Demand limiting(optional)

## Safety Protections

- ✿ Short circuit protection
- ✿ Compressor motor over load protection (3 phase)
- ✿ Compressor motor overheat protection
- ✿ Under/over voltage phase failure relay
- ✿ High condenser pressure
- ✿ Low evaporator pressure
- ✿ Freeze protection (low chilled water leaving temperature)
- ✿ Chilled/condenser water flow loss
- ✿ Low differential oil pressure
- ✿ High discharge temperature
- ✿ High oil sump temperature
- ✿ High bearing temperature
- ✿ High motor temperature
- ✿ Compressor run error
- ✿ Compressor no stop
- ✿ Compressor surge
- ✿ Power loss
- ✿ Sensor error
- ✿ Refrigerant loss
- ✿ Reverse rotation
- ✿ VFD fault (if VFD is supplied)/Starter fault
- ✿ Oil pump fault
- ✿ Emergency stop

Controller shall be able to retain up to 10 alarm conditions complete with time of failure and all critical sensor readings. This aids service technicians in their trouble shooting task enabling downtime and nuisance trip-outs to be minimized.

## EXECUTION

### INSTALLATION

Chiller shall be installed strictly according to manufacturer's recommendations as stipulated in the installation manual, drawings and tender documents. Care should be taken to provide necessary service clearance as required in the manufacturer's drawing. Install the strainers at the inlet to the evaporator to prevent debris or other particles entering to the evaporator during piping work and initial flushing the system. Required coordination to be done with the electrical contractor and the control contractors to ensure electrical supply and required communications links are established.

### START-UP/ COMMISSIONING

Chiller shall be commissioned by a service representative from manufacturer or by their local representative. The service personnel shall be trained and authorized by the manufacturer for start up of the supplied units. The start-up shall include briefing operators on chiller operations and maintenance as well.



#### Malaysia

Lot 5755-6,  
Kidamai Industrial Park,  
Bukit Angkat,  
43000 Kajang,  
Selangor, Malaysia

Tel: +603-8924 9000  
Fax: +603-8739 5020

#### China

No. 1 Dunham-Bush Road,  
Laishan District,  
Yantai,  
Shandong Province,  
China 264003

Tel: +86-535-739 7888  
Fax: +86-535-739 7999

#### United Kingdom

8 Downley Road,  
Havant,  
Hampshire,  
England PO9 2JD

Tel : +44-23-9247 7700  
Fax: +44-23-9245 0396

#### United States of America

1800 SE 38th Avenue,  
Homestead,  
Florida 33035  
United States of America

Tel: +1(786)-800 9999  
Fax: +1(786)-527 3539

#### United Arab Emirates

Office # 2606,  
Fortune Executive Towers,  
Cluster T1, Jumeirah Lake Tower  
Dubai, UAE

Tel: +971-4-443 9207  
Fax: +971-4-443 9208

#### South Africa

No. 57 Sovereign Drive  
Route 21 Corporate Park  
Irene, Pretoria  
South Africa

Tel: +27-12-345 4202  
Fax: +27-12-345 4203

#### India

Unit no : 804 , 8th Floor  
Spaze Platinum Towers,  
Sector-47, Sohna Road,  
Gurgaon-122018, India

Tel: +91-124-414 4430

#### Indonesia

The Boulevard Office,  
3F2 Jl. Fachrudin No.5,  
Kp. Bali, Tanah Abang  
Jakarta Pusat - 10250, Indonesia

Tel: +62-21-2123 1392

#### Thailand

48/39 Soi Praditmanutham 19  
Praditmanutham Road,  
Lat Pharo, Bangkok 10230  
Thailand

Tel: +66-0-2610 3749  
Fax: +66-0-2610 3601

#### Singapore

2 Kallang Pudding Road  
#07-07 Mactech Building  
Singapore 349307

Tel: +65-6842 2012  
Fax: +65-6842 2013

#### Vietnam

10th Floor, Nam A Bank Tower,  
201-203 Cach Mang Thang 8 Street,  
District 3, Ho Chi Minh City,  
Vietnam

Tel: +84-8-6290 3108  
Fax: +84-8-6290 3109

**DUNHAM-BUSH®**

info@dunham-bush.com  
www.dunham-bush.com



Products that perform...By people who care

Manufacturer reserves the right to change specifications without prior notice.

M-S-04103F-0721